

Installation and Maintenance Manual

PUMP FOR HYDRAULIC STEERING SYSTEMS

| | | |
|----------|----------|--------|
| UP25 F | UP28 R | UP25 T |
| UP28 F | UP33 R | UP28 T |
| UP33 F | UP39 R | UP33 T |
| UP39 F | UP39-I R | UP39 T |
| UP45 F | UP45 R | UP45 T |
| UP25NV F | UP45-I R | |
| UP33NV F | | |

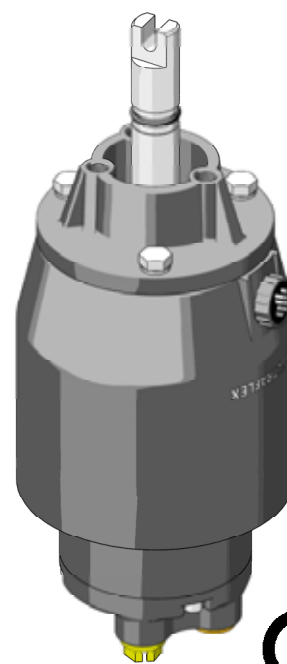
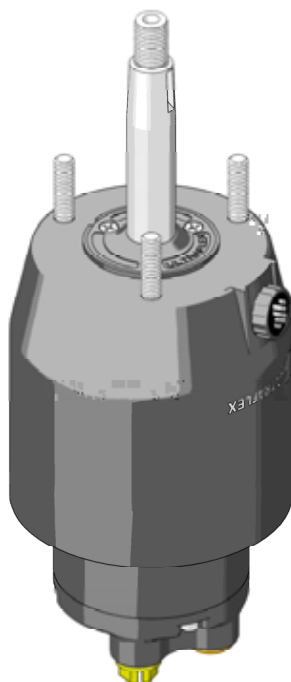

ULTRAFLEX[®]

UK
page. 2

I
pag. 35

F
page. 69



PARTNER



ENGLISH

ITALIANO

FRANÇAIS

CE



Dear Customer,

We would like to thank you for choosing an **ULTRAFLEX** product.

ULTRAFLEX has been a leader in steering systems for pleasure and professional boats for many years. **ULTRAFLEX** production is since ever synonymous of reliability and safety.

All **ULTRAFLEX** products are designed and manufactured to ensure the best performance. To ensure your safety and to maintain a high quality level, **ULTRAFLEX** products are guaranteed only if they are used with original spare parts.

ULTRAFLEX and **UFLEX** Quality Management Systems are certified CISQ-IQNet by the Italian Shipping Registry (RINA), in conformity with the UNI EN ISO 9001:2008 rule. **ULTRAFLEX** certification No. 6669/02/S (former 420/96). **UFLEX** certification No. 8875/03/S.

The quality management system involves all the company resources and processes starting from the design, in order to:

- ensure product quality to the customer;
- maintain and improve the quality standards constantly;
- pursue a continuous process improvement to meet the market needs and to increase the customer satisfaction

ULTRAFLEX Environmental Management System is certified CISQ-IQNet by the Italian Shipping Registry (RINA), in conformity with the UNI EN ISO 14001 rule. **ULTRAFLEX** certification No. EMS-1282/S.

Products for pleasure boats are constantly tested to check their conformity with the 2013/53/EU.



"**ULTRAFLEX** has over 80 years of experience in the marine industry and is a world leader in the production of mechanical, hydraulic and electronic steering systems, control boxes and steering wheels for any kind of pleasure, fishing or commercial boats.

The key factors which explain the increasing success of our products all over the world are the reliability of our products and the before and after sale service, the quality of the company organization and of the human resources and the continuous spending in research and development".

ULTRAFLEX S.p.A.

16015 Casella (Genova) Italia - Via Crose, 2

TABLE OF CONTENTS 

DOCUMENT REVISIONS 4
 MANUAL USE AND SYMBOLS USED 5
 INFORMATIVE LETTER 6
 WARRANTY 6

SECTION 1 - PRODUCT DESCRIPTION 

1.1 HYDRAULIC STEERING SYSTEM OPERATION 7
 1.2 WARNINGS FOR THE CORRECT PRODUCT USE 7
 1.3 SYSTEM CONFIGURATIONS 8
 1.4 PUMP DESCRIPTION 8
 1.5 PUMP TECHNICAL FEATURES 9

SECTION 2 - TRANSPORT 

2.1 GENERAL WARNINGS 12
 2.2 PACKAGING CONTENTS 12

SECTION 3 - INSTALLATION 

3.1 TOOLS NECESSARY FOR THE INSTALLATION OF PUMPS UP25 F - UP28 F -UP33 F - UP39 F - UP45 F
 UP25NV F - UP33NV F 15
 3.2 PUMP UP25 F - UP28 F -UP33 F - UP39 F - UP45 F - UP25NV F - UP33NV F INSTALLATION 15
 3.3 TOOLS NECESSARY FOR THE INSTALLATION OF PUMPS UP28 R -UP33 R - UP39 R - UP45 R 17
 3.4 PUMP UP28 R -UP33 R - UP39 R - UP45 R INSTALLATION 17
 3.5 TOOLS NECESSARY FOR THE INSTALLATION OF PUMPS UP39-I R - UP45-I R 19
 3.6 PUMPS UP39-I R - UP45-I R INSTALLATION 19
 3.7 TOOLS NECESSARY FOR THE INSTALLATION OF UP25 T - UP28 T -UP33 T - UP39 T - UP45 T PUMPS 21
 3.8 PUMP UP25 T - UP28 T -UP33 T - UP39 T - UP45 T INSTALLATION 21
 3.9 TYPES OF INSTALLATION 24
 3.10 HOSE CONNECTION TO THE SYSTEM 25
 3.10.1 HOSE CONNECTION TO THE SYSTEM FOR MODELS UP25 F-R-T, UP28 F-R-T, UP33 F-R-T, UP39 F-R-T,
 UP45 F-R-T 25
 3.10.2 HOW TO CHOOSE THE RIGID PIPES FOR MODELS UP39 I R - UP 45 I R 26
 3.10.3 HOSE CONNECTION TO THE SYSTEM FOR MODELS UP39-I R - UP45 I R 27
 3.11 FILLING AND PURGING 28
 3.11.1 POSITIONING OF THE OIL BOTTLE 29
 3.11.2 PURGING PROCEDURE 29
 3.12 GENERAL RECOMMENDATION 29

SECTION 4 - SAFETY WARNINGS 

4.1 SAFETY WARNINGS DURING USE AND INSTALLATION 30
 4.2 CLOTHING 30

SECTION 5 - MAINTENANCE 

5.1 ORDINARY MAINTENANCE 31
 5.2 STEERING WHEEL DISASSEMBLY 31
 5.3 TROUBLESHOOTING 31

SECTION 6 - DISMANTLING 

6.1 DISMANTLING 33





DOCUMENT REVISIONS

| Rev. | Date | Revision description |
|-------------|-------------|---|
| 0 | 10/02/2012 | First edition |
| 1 | 20/11/2012 | Models 45 F - R - I R - T have been added and swiveling fitting change |
| 2 | 30/07/2013 | Model UP39-I R has been added |
| 3 | 28/02/2014 | Corrections of picture references on pages 8 and 9 |
| 4 | 16/07/2014 | Modification of chapters "Packaging contents" and "Positioning of the oil bottle" |

MANUAL USE AND SYMBOLS USED

THE INSTALLATION AND MAINTENANCE MANUAL is the document accompanying the product from its sale to its replacement and discharge. The manual is an important part of the product itself. It is necessary to read carefully the manual, before ANY ACTIVITY involving the product, handling and unloading included.

In this manual the following symbols are used to ensure the user safety and to guarantee the correct operation of the product:

- 
DANGER
➔
Immediate hazards which CAUSE severe personal injury or death.
- 
WARNING
➔
Denotes that a hazard exists which can result in injury or death if proper precautions are not taken.
- 
CAUTION
➔
Denotes a reminder of safety practices or directs attention to unsafe practices which could result in personal injury or damage to the craft or components or to the environment.
- 
NOTICE
➔
Important information for the correct installation and for maintenance, that does not cause any damage.
- 
➔
The symbol aside indicates all the operations which must be carried out by qualified or skilled staff, in order to avoid hazards. We recommend training the staff in charge of the product installation and checking their knowledge.

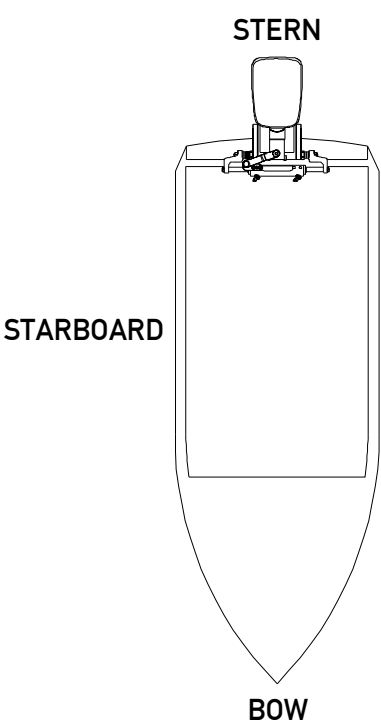

➔

The picture aside explains the meaning of some nautical words contained in this manual.

LEGEND

m.p.h. = miles per hour
 km/h = kilometres per hour

10 m.p.h. = 8,69 knots
 10 m.p.h. = 16,1 km/h
 10 knots = 11,5 m.p.h.
 10 knots = 18,5 km/h
 10 km/h = 6,21 m.p.h.
 10 km/h = 5,4 knots



INFORMATIVE LETTER

This installation and maintenance manual is an integrant part of the product and should be easily available to staff in charge of use and maintenance.

The user must know the content of this manual.

ULTRAFLEX declines all responsibility for possible mistakes in this manual due to printing errors.

Although the main features of the type of product described are not subject to change, **ULTRAFLEX** Company reserves the right to modify any parts, details and accessories it deems necessary to improve the product or for manufacturing or commercial requirements, at any time and without being obliged to update this manual immediately.

ALL RIGHTS ARE RESERVED. Publishing rights, trademarks, part numbers and photographs of **ULTRAFLEX** products contained in this manual are **ULTRAFLEX** property.

Great care has been taken in collecting and checking the documentation contained in this manual to make it as complete and comprehensible as possible. Nothing contained in this manual can be interpreted as warranty either expressed or implied - including, not in a restricted way, the suitability warranty for any special purpose. Nothing contained in this manual can be interpreted as a modification or confirmation of the terms of any purchase contract.

⚠ WARNING

To ensure the correct product and component operation, the product must be installed by qualified staff. In case of part damage or malfunction, please contact the qualified staff or our Technical Assistance Service.

TECHNICAL ASSISTANCE SERVICE

UFLEX S.r.l.

Via Milite Ignoto,8A
16012 Busalla (GE)-Italia
Tel: +39.010.962.01
Fax: +39.010.962.0333
Email: ut@ultraflexgroup.it
www.ultraflexgroup.it

North - South - Central America:

UFLEX USA

6442 Parkland Drive
Sarasota, FL 34243
Ph: +1.941.351.2628
Fax: +1.941.360.9171
Email: uflex@uflexusa.com
www.uflexusa.com

WARRANTY

ULTRAFLEX guarantees that its products are well designed and free from manufacturing and material defects, for a period of two years from the date of manufacturing.

For the products which are installed and used on working or commercial boats the warranty is limited to one year from the date of manufacturing.

If during this period the product proves to be defective due to improper materials and/or manufacture, the manufacturer will repair or replace the defective parts free of charge.

Direct or indirect damage is not covered by this warranty. In particular the company is not responsible and this warranty will not cover the damage resulting from incorrect installation or use of the product (except for replacement or repair of defective parts according to the conditions and terms above).

This warranty does not cover the products installed on race boats or boats used in competitions.

The descriptions and illustrations contained in this manual should be used as general reference only.

For any further information please contact our Technical Assistance Service.

ULTRAFLEX steering system components are marked **CE** according to the Directive 2013/53/EU.

We remind you that only **CE** marked steering systems must be used on the boats marked **CE**.

We inform you that the **ULTRAFLEX** warranty is null if some **ULTRAFLEX** components are installed on a steering system together with products of other brands.



1 PRODUCT DESCRIPTION

1.1 Hydraulic steering system operation

All **ULTRAFLEX** hydraulic steering systems are designed in conformity with UNI-EN-ISO 10592 and A.B.Y.C. P21 regulations. All **ULTRAFLEX** steering systems can operate at temperatures between -18°C (0°F) and $+77^{\circ}\text{C}$ ($+170^{\circ}\text{F}$). All the components are made for the marine environment, using materials and working processes which offer long life and safety under the most extreme conditions. A hydraulic steering system consists of a steering pump located on the dashboard, a cylinder tied to the rudder or to the outboard or sterndrive engine and the connecting hoses (see picture). Under normal operating conditions, a turn of the steering wheel will pump the oil, which flows in through the hoses to the cylinder, according to the turn direction. With the consequent cylinder movement the oil will flow to the pump through the hoses and at the same time moves the engine or the helm which are connected to the cylinder. The pumps equipped with a nonreturn valve, which prevents outgoing fluid from returning along the same hose, allow the operation of the steering systems with two or more steering stations. The pumps series "NV" are not equipped with a nonreturn valve so they cannot be used with two or more steering systems. The cylinders are double-acting and they can be balanced or unbalanced. In unbalanced cylinders the two chambers have different volumes and therefore they require a different number of steering wheel turns and a different steering wheel rotation effort with the same movement in the two directions. The unbalanced cylinders cannot be used with the pumps series "NV". The balanced cylinders require the same number of turns of the steering wheel to move the helm from the centre to the end of stroke in the two opposed directions.

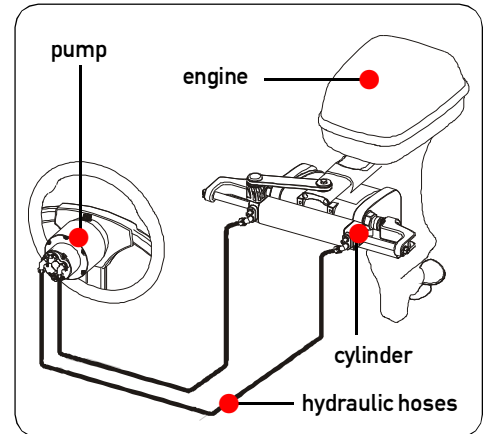

A well balanced steering system needs a correct choice of the pump for the cylinder. **ULTRAFLEX** produces different pump models, which have different capacity (cm^3 of oil moved each steering wheel turn) and for each type of installation. While choosing the pump it is important to consider the cylinder volume. The number of starboard and port turns is determined by the ratio between the cylinder volume and the pump capacity.

Example: if the pump has a capacity of 28 cm^3 [1.7 cu.in.] and the cylinder has a volume of 120 cm^3 [7.3 cu.in.], the formula looks like this: $120/28=4.2$. Accordingly, the steering wheel will turn about 4 times before the cylinder will completely turn from one side to the other. In case of installations with double cylinders connected in parallel the cylinder volume must be added. Applications with less than 4 turns are not recommended, as they need a higher effort, also applications with more than 8 turns are not recommended, as the response of the boat to steer is slowly.

1.2 Warnings for the correct product use

⚠ DANGER

Do not modify the steering cylinder in any way to fit it to your application, otherwise the cylinder will no longer operate in safety and it will endanger the boat and the occupants.

⚠ WARNING

All **ULTRAFLEX** steering systems must not be installed on boats equipped with engines whose maximum horsepower is higher than the horsepower rating approved by boat manufacturer.

⚠ WARNING

ULTRAFLEX steering systems must not be installed on race boats.

⚠ WARNING

The pumps UP25NV F and UP33NV F cannot be used with unbalanced cylinders and with double steering system.



1.3 System configurations

The pumps UP25 - UP28 - UP33 - UP39 - UP45 can be installed in a single or double steering system and used with different types of configurations of front, side or inboard cylinders.

The pumps series "NV" cannot be installed in a double steering system and they cannot be used with unbalanced cylinders.

⚠ CAUTION

Always connect the hoses correctly as indicated in the installation and maintenance manuals of the corresponding hydraulic cylinders.

1.4 Pump description

The pumps UP25 - UP28 - UP33 - UP39 - UP45 have been designed and manufactured to be used as a component in the hydraulic steering systems, as described in the previous paragraph.

The pumps UP25 F - UP28 F - UP33 F - UP39 F - UP45 F - UP25NV F - UP33NV F must be installed on the front part of the boat dashboard or semi-built-in through flanges X64 or X57 (supplied separately), the pumps UP28 R - UP33 R - UP39 R - UP39-I R - UP45 R - UP45-I R must be assembled on the rear part of the boat dashboard, and the pumps UP25 T - UP28 T - UP33 T - UP39 T - UP45 T must be assembled by means of tilt X52 (supplied separately).

The following pictures show the main pump components:

- | | |
|---|---|
| <ul style="list-style-type: none"> ➊ Pump UP25 F - UP28 F - UP33 F - UP39 F - UP45 F - UP25NV F - UP33NV F ➋ Tank plug with bleed ➌ Steering wheel connection shaft ➍ Connections to the cylinder/s ➎ Connections to the additional stations (that can be used with series "NV") | <ul style="list-style-type: none"> ➏ M6 dowels for fixing the pump to the dashboard ➐ Pump UP28 R - UP33 R - UP39 R - UP39-I R - UP45 R - UP45-I R ➑ M8 dowels for fixing the pump to the dashboard ➒ Pump UP25 T - UP28 T - UP33 T - UP39 T - UP45 T ➓ Connection shaft to tilt X52 |
|---|---|

UP25 F - UP28 F - UP33 F - UP39 F - UP45 F - UP25NV F - UP33NV F

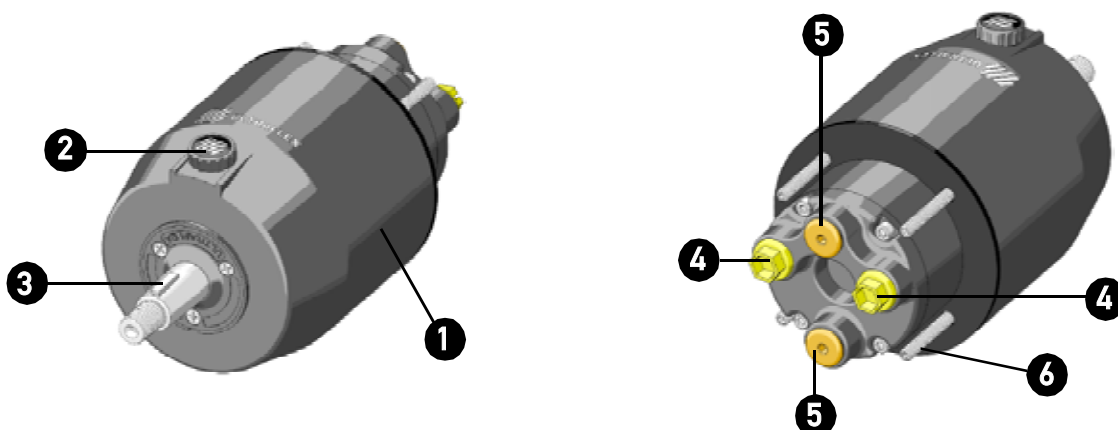

UP28 R - UP33 R - UP39 R - UP39-I R - UP45 R - UP45-I R

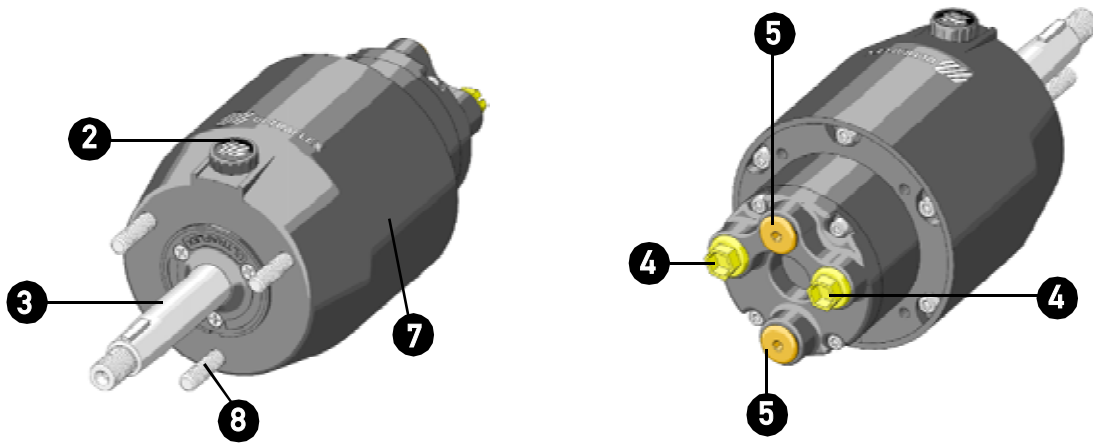

UP25 T - UP28 T - UP33 T - UP39 T - UP45 T

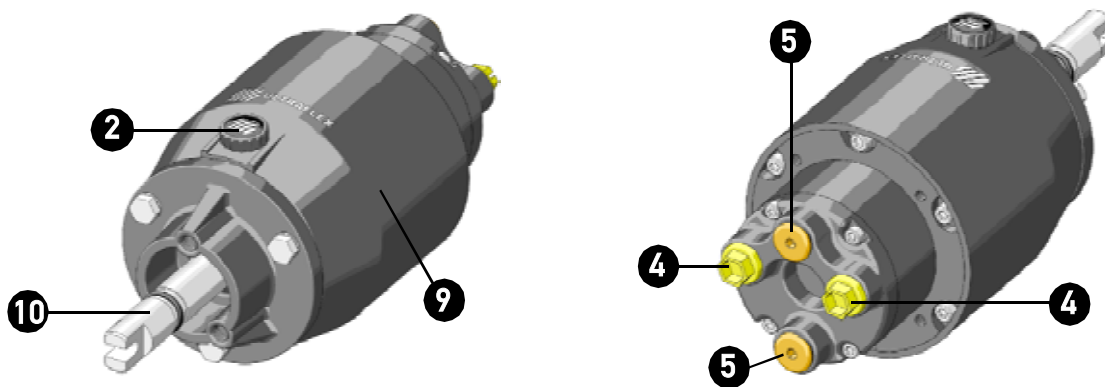

1.5 Pump technical features

| SPECIFICATIONS | PUMP UP25 F | PUMP UP25NV F | PUMP UP28 F | PUMP UP33 F | PUMP UP33NV F | PUMP UP39 F | PUMP UP45 F |
|--|-------------------------------|-------------------------------|-----------------------------|-----------------------------|-----------------------------|-----------------------------|-----------------------------|
| Capacity | 23,5 cc/rev. - 1,4 cu.in/rev. | 23,5 cc/rev. - 1,4 cu.in/rev. | 28 cc/rev. - 1,7 cu.in/rev. | 33 cc/rev. - 2,0 cu.in/rev. | 33 cc/rev. - 2,0 cu.in/rev. | 39 cc/rev. - 2,4 cu.in/rev. | 45 cc/rev. - 2,7 cu.in/rev. |
| Pressure relief valve release pressure | 70 bar (1000 psi) | 70 bar (1000 psi) | 70 bar (1000 psi) | 70 bar (1000 psi) | 70 bar (1000 psi) | 70 bar (1000 psi) | 70 bar (1000 psi) |
| No. of pistons | 5 | 5 | 5 | 7 | 7 | 7 | 7 |
| Max. steering wheel diameter | 711 mm (28 in.) | 711 mm (28 in.) | 711 mm (28 in.) | 711 mm (28 in.) | 711 mm (28 in.) | 711 mm (28 in.) | 711 mm (28 in.) |
| Max. steering wheel height | 152 mm (6 in.) | 152 mm (6 in.) | 152 mm (6 in.) | 152 mm (6 in.) | 152 mm (6 in.) | 152 mm (6 in.) | 152 mm (6 in.) |
| Weight | 5 kg (11 lbs) | 5 kg (11 lbs) | 5 kg (11 lbs) | 5 kg (11 lbs) | 5 kg (11 lbs) | 5 kg (11 lbs) | 5 kg (11 lbs) |
| Oil | OL150 Ultraflex | OL150 Ultraflex | OL150 Ultraflex | OL150 Ultraflex | OL150 Ultraflex | OL150 Ultraflex | OL150 Ultraflex |

⚠ CAUTION

The release pressure of the pressure relief valves does not correspond to the system normal pressure but it represents only the use limits.



UP25 F - UP28 F - UP33 F - UP39 F - UP45 F - UP25NV F - UP33NV F

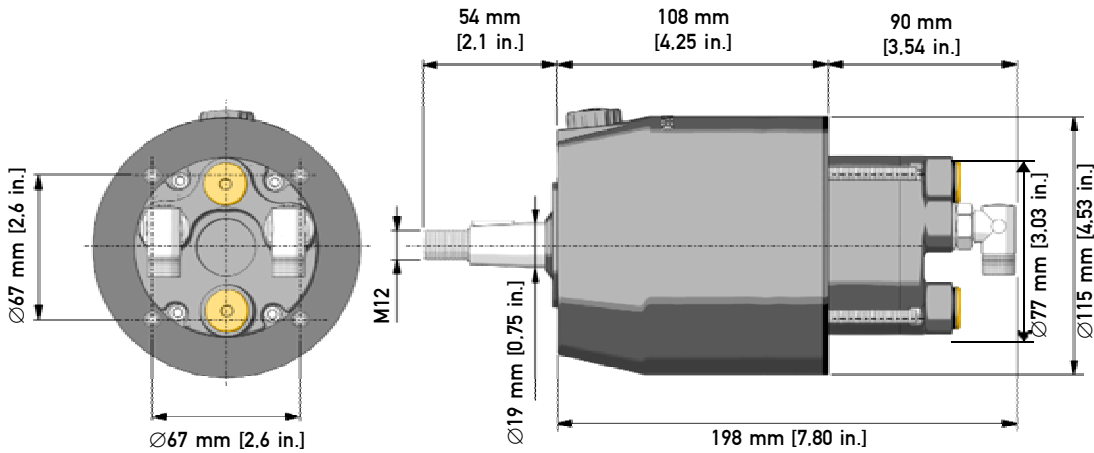

| SPECIFICATIONS | PUMP UP28 R | PUMP UP33 R | PUMP UP39 R | PUMP UP45 R | PUMP UP45-I R |
|--|-----------------------------|-----------------------------|-----------------------------|-----------------------------|-----------------------------|
| Capacity | 28 cc/rev. - 1,7 cu.in/rev. | 33 cc/rev. - 2,0 cu.in/rev. | 39 cc/rev. - 2,4 cu.in/rev. | 45 cc/rev. - 2,7 cu.in/rev. | 45 cc/rev. - 2,7 cu.in/rev. |
| Pressure relief valve release pressure | 70 bar (1000 psi) | 70 bar (1000 psi) | 70 bar (1000 psi) | 70 bar (1000 psi) | 70 bar (1000 psi) |
| No. of pistons | 5 | 7 | 7 | 7 | 7 |
| Max. steering wheel diameter | 711 mm (28 in.) | 711 mm (28 in.) | 711 mm (28 in.) | 711 mm (28 in.) | 711 mm (28 in.) |
| Max. steering wheel height | 152 mm (6 in.) | 152 mm (6 in.) | 152 mm (6 in.) | 152 mm (6 in.) | 152 mm (6 in.) |
| Weight | 5 kg (11 lbs) | 5 kg (11 lbs) | 5 kg (11 lbs) | 5 kg (11 lbs) | 5 kg (11 lbs) |
| Oil | OL150 Ultraflex | OL150 Ultraflex | OL150 Ultraflex | OL150 Ultraflex | OL150 Ultraflex |

⚠ CAUTION

The release pressure of the pressure relief valves does not correspond to the system normal pressure but it represents only the use limits.

UP28 R - UP33 R - UP39 R - UP45 R

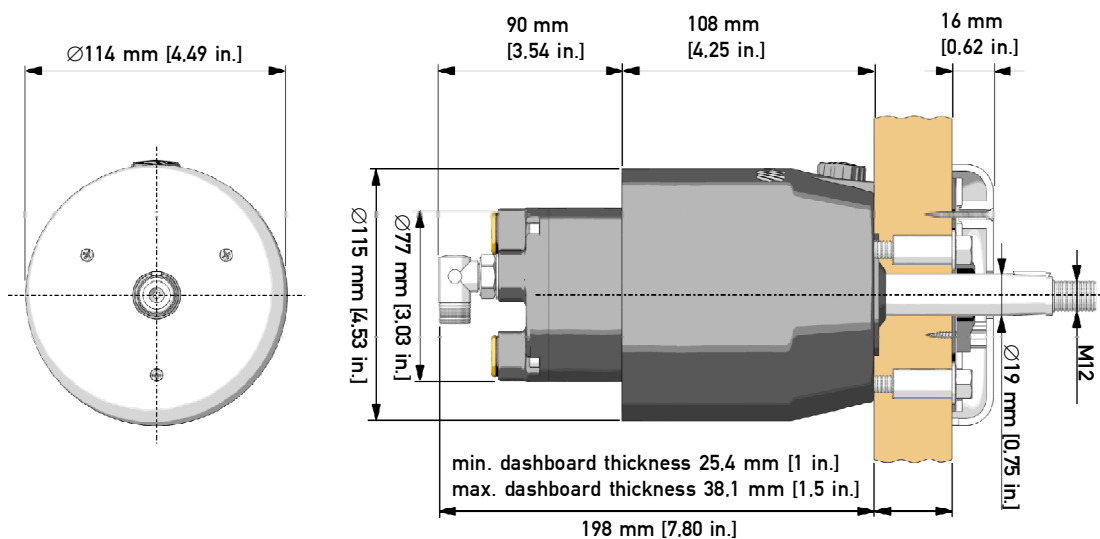

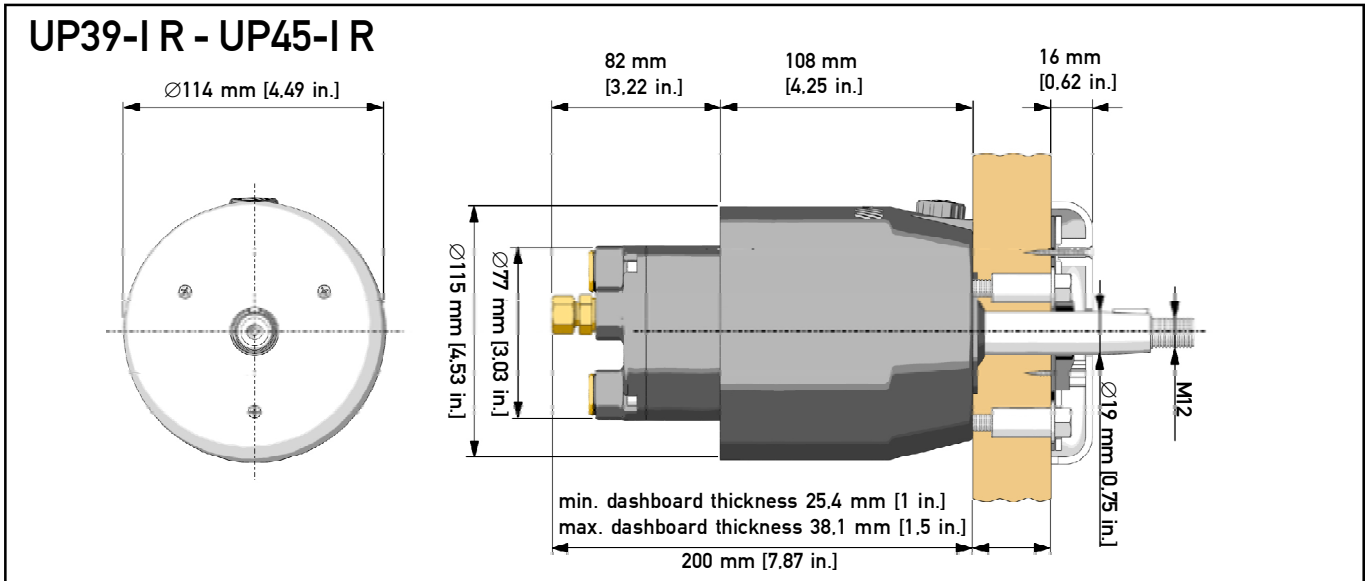

| SPECIFICATIONS | PUMP UP25 T | PUMP UP28 T | PUMP UP33 T | PUMP UP39 T | PUMP UP45 T |
|--|-----------------------------|-----------------------------|-----------------------------|-----------------------------|-----------------------------|
| Capacity | 25 cc/rev. - 1,5 cu.in/rev. | 28 cc/rev. - 1,7 cu.in/rev. | 33 cc/rev. - 2,0 cu.in/rev. | 39 cc/rev. - 2,4 cu.in/rev. | 45 cc/rev. - 2,7 cu.in/rev. |
| Pressure relief valve release pressure | 70 bar (1000 psi) | 70 bar (1000 psi) | 70 bar (1000 psi) | 70 bar (1000 psi) | 70 bar (1000 psi) |
| No. of pistons | 5 | 5 | 7 | 7 | 7 |
| Max. steering wheel diameter | 406 mm (16 in.) | 406 mm (16 in.) | 406 mm (16 in.) | 406 mm (16 in.) | 406 mm (16 in.) |
| Max. steering wheel height | 152 mm (6 in.) | 152 mm (6 in.) | 152 mm (6 in.) | 152 mm (6 in.) | 152 mm (6 in.) |
| Weight | 5 kg (11 lbs) | 5 kg (11 lbs) | 5 kg (11 lbs) | 5 kg (11 lbs) | 5 kg (11 lbs) |
| Oil | OL150 Ultraflex | OL150 Ultraflex | OL150 Ultraflex | OL150 Ultraflex | OL150 Ultraflex |

⚠ CAUTION

The release pressure of the pressure relief valves does not correspond to the system normal pressure but it represents only the use limits.

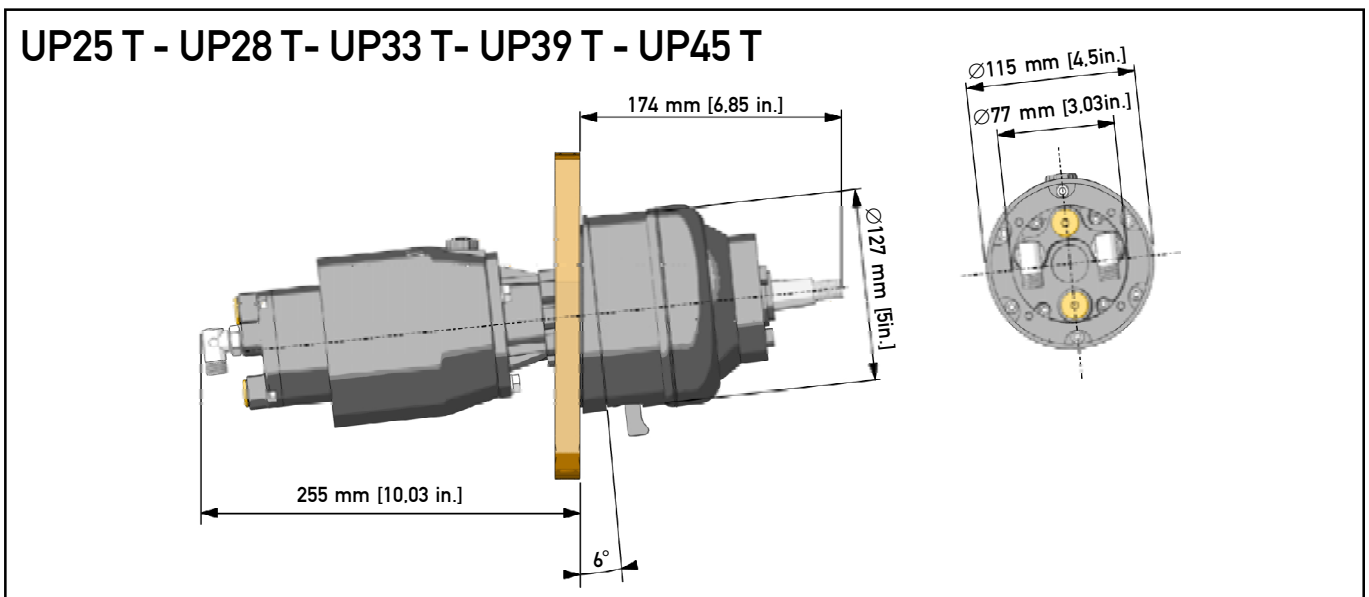

⚠ CAUTION

The pumps UP25 T - UP28 T - UP33 T - UP39 T - UP45 T can only be used with tilt **ULTRAFLEX X52** (supplied separately).



2 TRANSPORT

2.1 General warnings

The pumps UP25-UP28-UP33-UP39-UP45 weight with their packaging is 5kg (11 pounds) and so they can be handled manually.

⚠ WARNING

The staff in charge of handling must operate with protective gloves and safety shoes.

2.2 Packaging contents

Before using the equipment check that the product has not been damaged during transport. Also make sure that all the standard components are in the packaging (see list). In case of damage, notify the claim to the forwarder and inform the supplier.

UP25 F - UP28 F - UP33 F - UP39 F - UP45 F - UP25NV F - UP33NV F

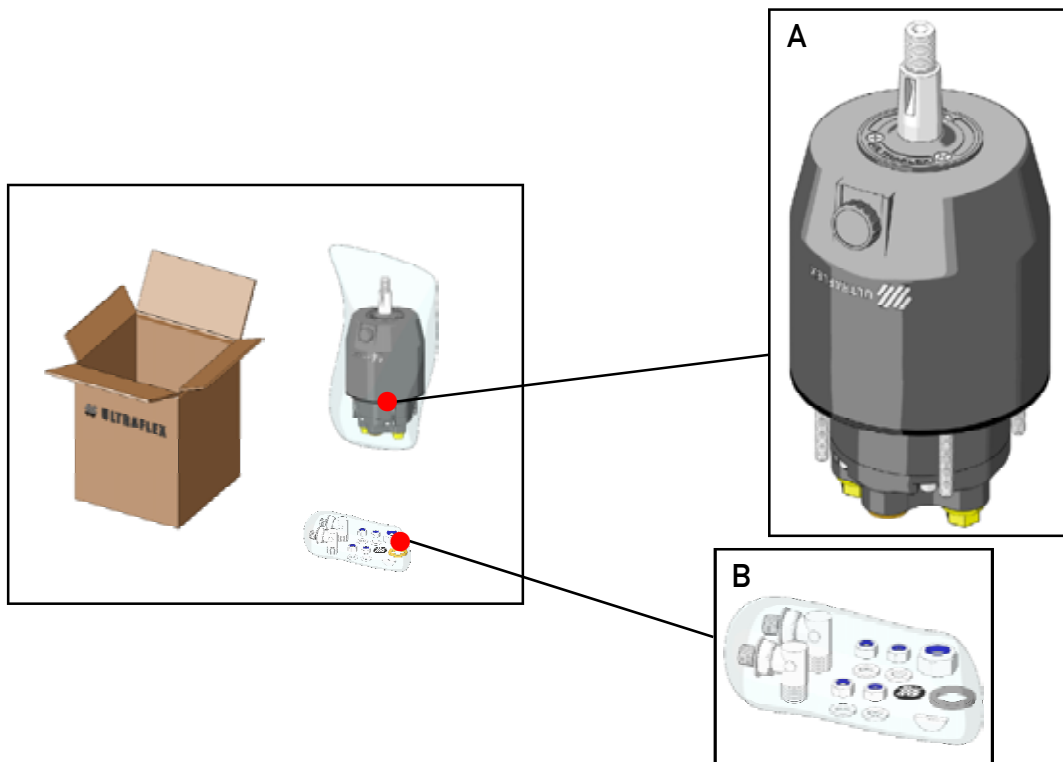

THE STANDARD PACKAGING CONTAINS:

A) No.1 pump UP25 F or UP28 F or UP33 F or UP39 F or UP45 F or UP25NV F or UP33NV F with gaskets to fix it to the instrument panel.

B) No. 2 90° swinging unions to connect the Kit OB hoses (supplied separately);

- No. 4 nuts for fixing the pump to the dashboard;
- No. 4 washers for fixing the pump to the dashboard;
- No. 1 nut for steering wheel tightening;
- No. 1 washer for steering wheel tightening;
- No. 1 key for steering wheel tightening;
- No. 1 label for plug.



UP28 R - UP33 R - UP39 R - UP39-I R- UP45 R - UP45-I R

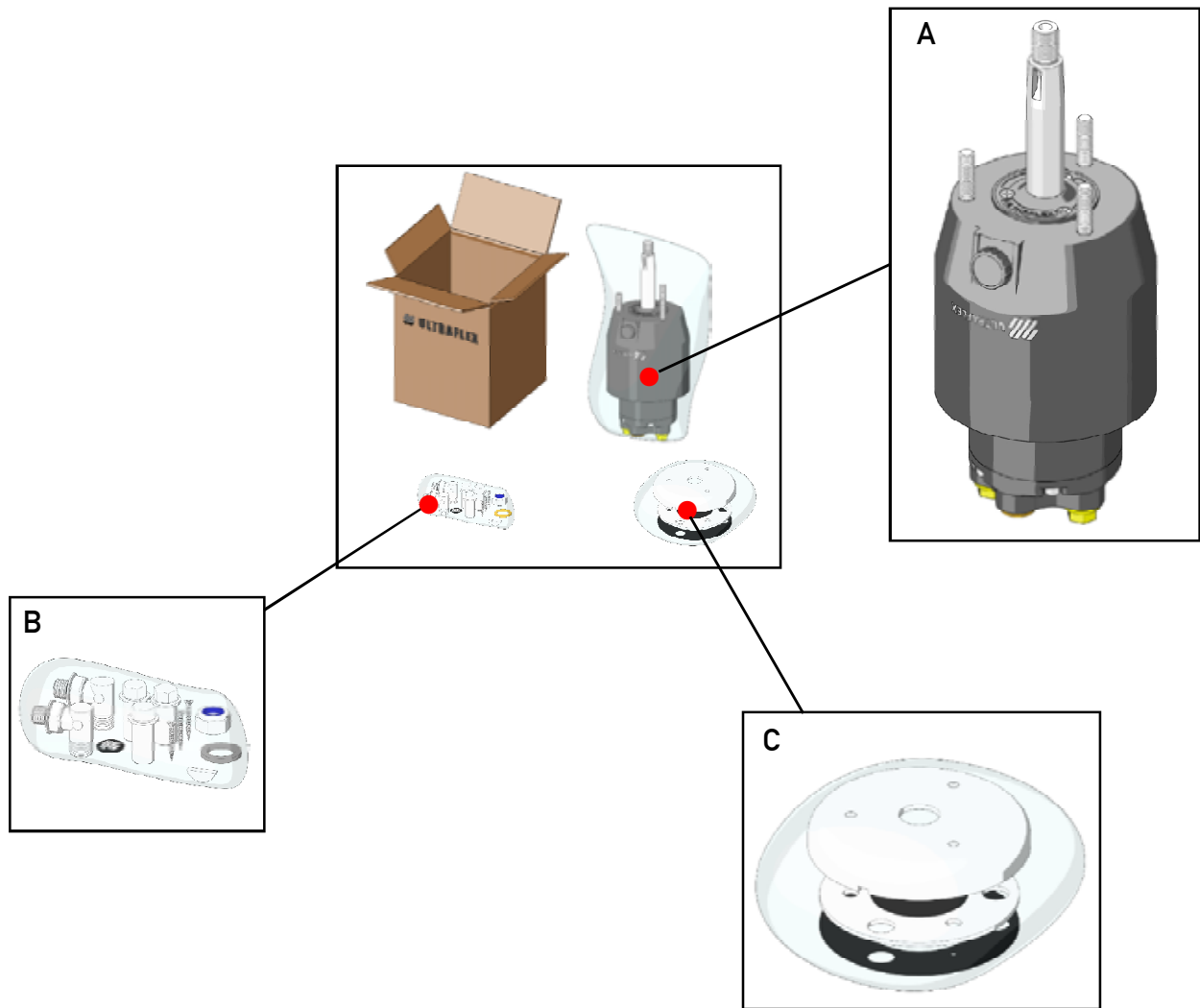

THE STANDARD PACKAGING CONTAINS:

A) No. 1 pump UP28 R or UP33 R or UP39 R or UP39-I R or UP45 R or UP45-I R.

B) No. 2 2 90° swinging unions (except pumps UP39-I R and UP45-I R) to connect the Kit OB hoses (supplied separately):
 No. 3 special screws for fixing the pump to the dashboard;
 No. 3 self-tapping screw for hub-cap fixing;
 No. 1 nut for steering wheel tightening;
 No. 1 washer for steering wheel tightening;
 No. 1 key for steering wheel tightening;
 No. 1 label for plug;

C) No. 1 gasket;
 No. 1 flange;
 No. 1 hub-cap.

NOTICE

Versions UP39-I R and UP45-I R are supplied with a special 1/4 NPT straight union for Ø 12 mm metal pipe.



UP25 T - UP28 T - UP33 T - UP39 T - UP45 T

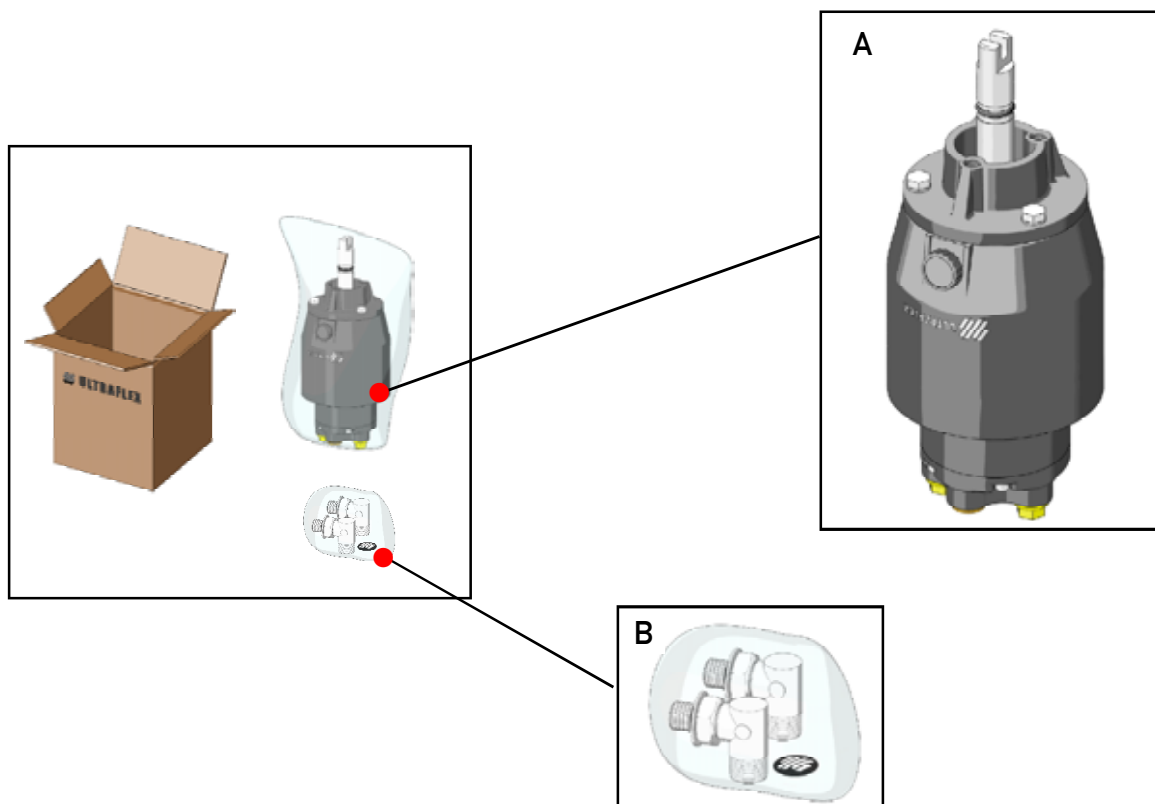

THE STANDARD PACKAGING CONTAINS:

A) n°1 pump UP25 T or UP28 T or UP33 T or UP39 T or UP45 T.

B) n°2 90° swinging unions to connect the Kit OB hoses (supplied separately):
n°1 label for plug.

⚠ CAUTION

The packaging must be disposed of according to the existing laws.



3 INSTALLATION

3.1 Tools necessary for the installation of pumps UP25 F - UP28 F - UP33 F - UP39 F - UP45 F - UP25NV F - UP33NV F

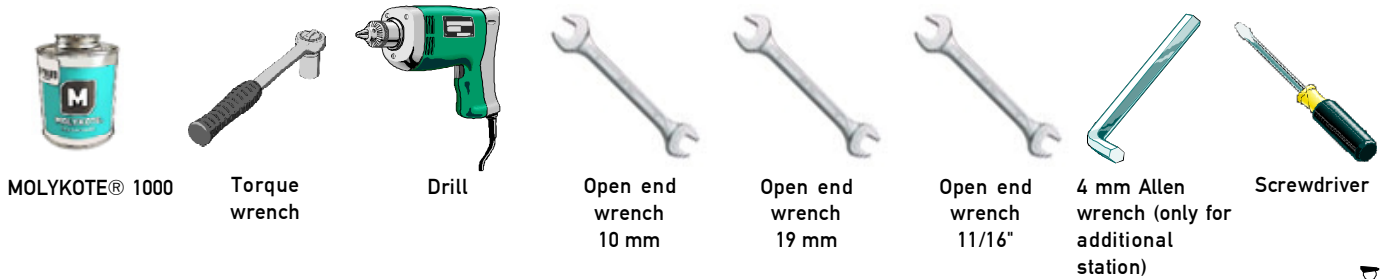

3.2 Pump UP25 F - UP28 F - UP33 F - UP39 F - UP45 F - UP25NV F - UP33NV F installation

1 Select a suitable place for the steering station. Make sure that there is enough manoeuvring space for the steering wheel and for the steering pump and its pipes and fittings.

⚠ WARNING

In order to fix the pump properly, the maximum dashboard thickness must be 30 mm [1.18 in.]. Different thicknesses could compromise the driving safety. Make sure that the breaking ring of the 4 self-locking nuts supplied is engaged by the dowel thread.

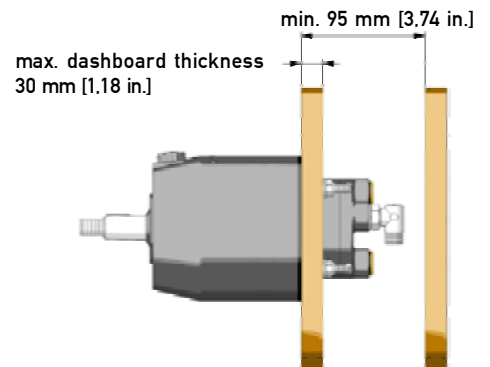

2 Remove the plugs (1) from the pump (2) by using a screwdriver.

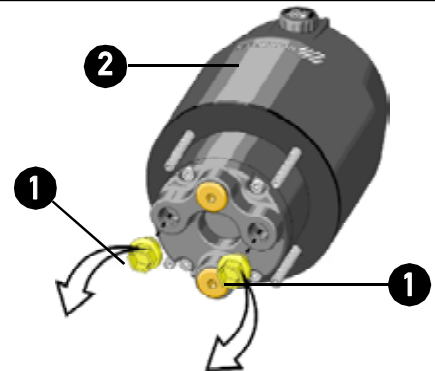

3 Screw the nuts completely on the corresponding 90° unions (3). Fit and screw the unions manually as indicated in the picture until they are inserted completely. Turn them until they are positioned correctly with respect to the pipes by unscrewing them no more than one revolution, then tighten the nuts with a 11/16" Allen wrench with a torque of 17.6 Nm (13 lb ft) until the washer touches the nut.

⚠ WARNING

DO NOT USE teflon tape or adhesive tape.
DO NOT PUT any thread sealant like Loctite 542 or similar products.

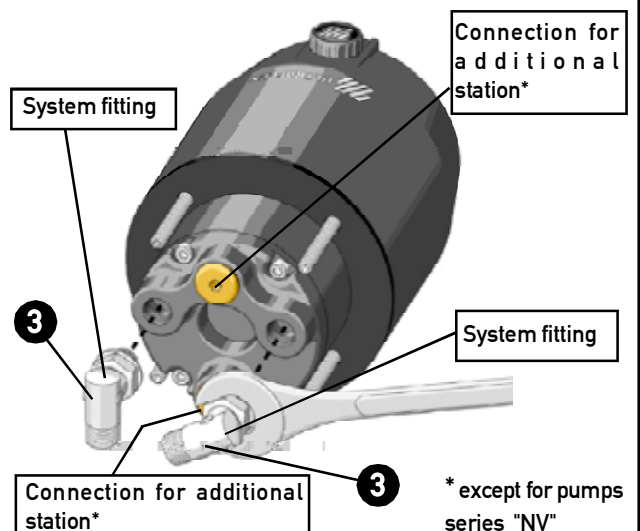

4 By using the proper template supplied with this manual, make the holes (4) required by the installation in the suitable position on the dashboard.

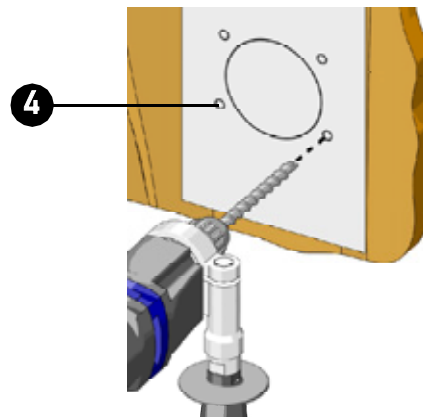

5 Position the pump (2) on the dashboard front side (5) interposing the gasket (6) and fix it by inserting the 4 washers (7) and by tightening the 4 self-locking nuts (8) with a 10 mm wrench and a torque of 10 Nm (7.4 lb ft).

⚠ CAUTION

If the self-locking nuts are disassembled (8), they must be replaced. (Contact our assistance service, see page 6).

⚠ WARNING

Install the pump by positioning the filling hole (9) towards the top (see the picture) for the right pump operation and to allow filling and purging the system completely (see par. 3.11).

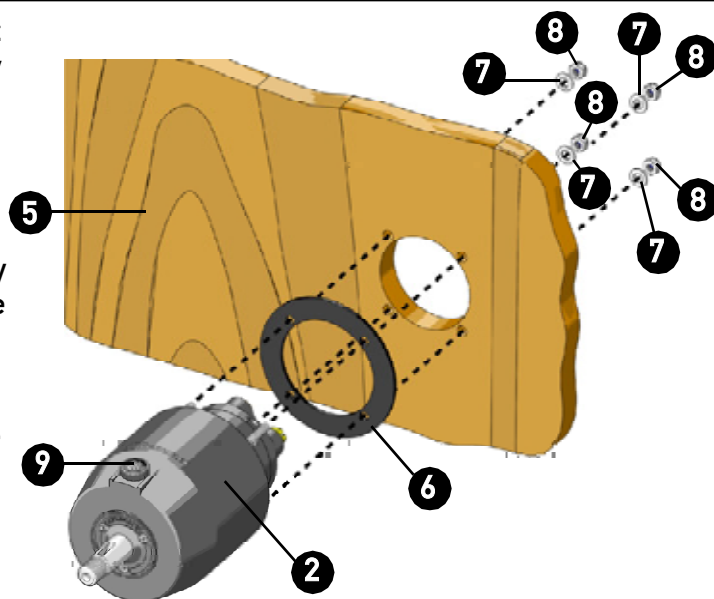

6 Position the steering wheel supplied separately (10) on the pump shaft (11) by using the suitable key (12). Insert the washer (13) and tighten the self-locking nut (14) with a 19 mm open end wrench and with a torque of 40 Nm (29.5 lb ft); then grease the thread by using some anti-seize grease MOLYKOTE® 1000 or a similar one.

⚠ CAUTION

If the self-locking nut (14) is disassembled, it must be replaced. (Contact our assistance service, see page 6).

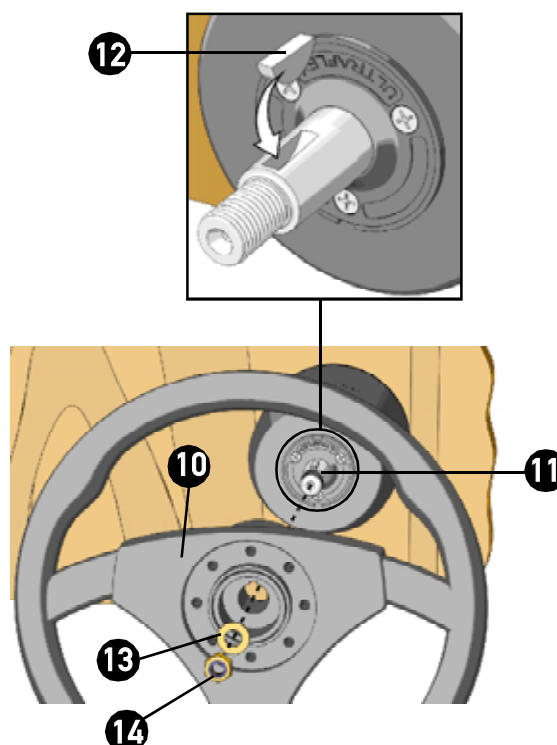

3.3 Tools necessary for the installation of pumps UP28 R - UP33 R - UP39 R - UP45 R



3.4 Pump UP28 R - UP33 R - UP39 R - UP45 R installation



1 Select a suitable place for the steering station. Make sure that there is enough manoeuvring space for the steering wheel and for the steering pump and its pipes and fittings.

⚠ WARNING

In order to fix the pump properly, the minimum dashboard thickness must be 25.4 mm [1 in.] and the maximum dashboard thickness must be 38.1 mm [1.5 in.]. Different thicknesses could compromise the driving safety.

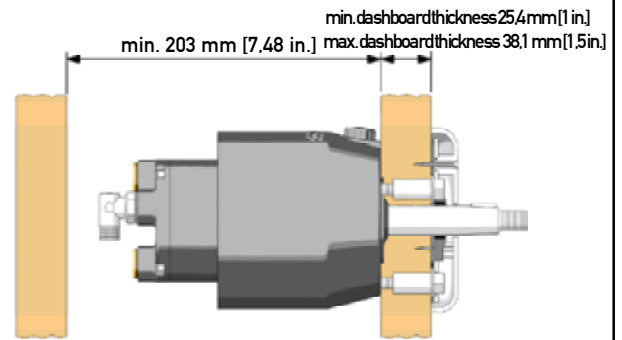

2 Remove the plugs (1) from the pump (2) by using a screwdriver.

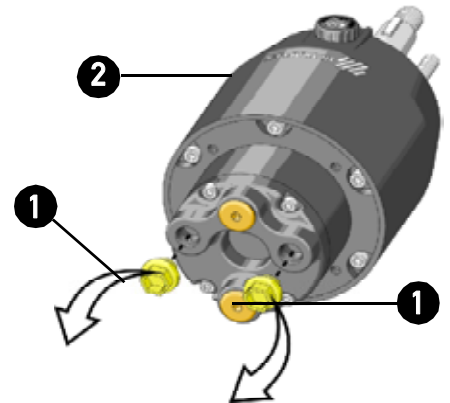

3 Screw the nuts completely on the corresponding 90° unions (3). Fit and screw the unions manually as indicated in the picture until they are inserted completely. Turn them until they are positioned correctly with respect to the pipes by unscrewing them no more than one revolution, then tighten the nuts with a 11/16" Allen wrench with a torque of 17.6 Nm (13 lb ft) until the washer touches the nut.

⚠ WARNING

DO NOT USE teflon tape or adhesive tape.
DO NOT PUT any thread sealant like Loctite 542 or similar products.

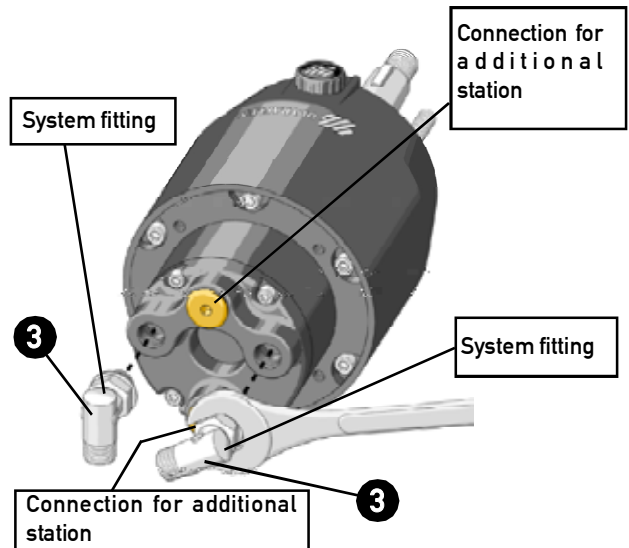

4 By using the proper template supplied with this manual, make the holes required by the installation in the suitable position on the dashboard.

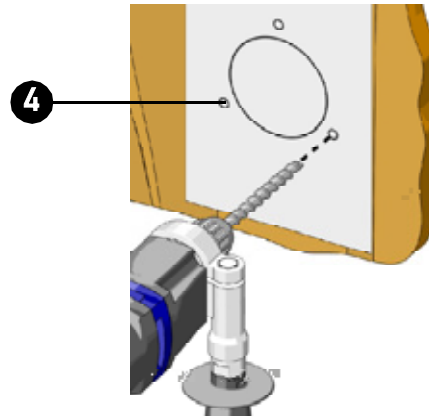

5 Position the pump (2) on the dashboard rear side (5). Then position the gasket (6) as shown in the picture and the flange (7) with the protective projecting part towards the dashboard outside. Fix the pump (2) with the 3 special screws (8) with a torque of 25 Nm (18.5 lb ft).

⚠ CAUTION

Make the shaft pass through the flange equipped with gasket by preventing the key seat from damaging the gasket itself.

⚠ WARNING

Install the pump by positioning the filling hole (9) towards the top (see the picture) for the right pump operation and to allow filling and purging the system completely (see par. 3.11).

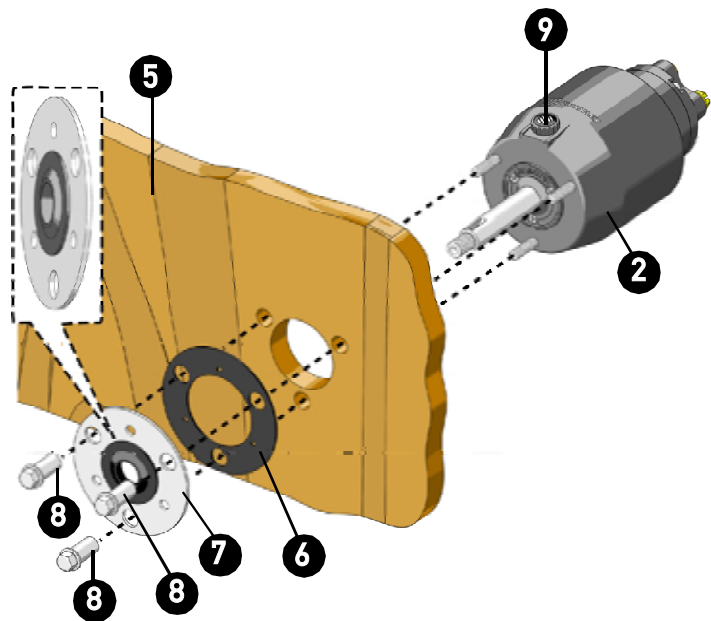

6 Position the plastic hub-cap (10) with the water discharge towards the bottom and fix it with the 3 self-tapping screws (11) supplied with a 1.5Nm (1.13 lb ft) torque.

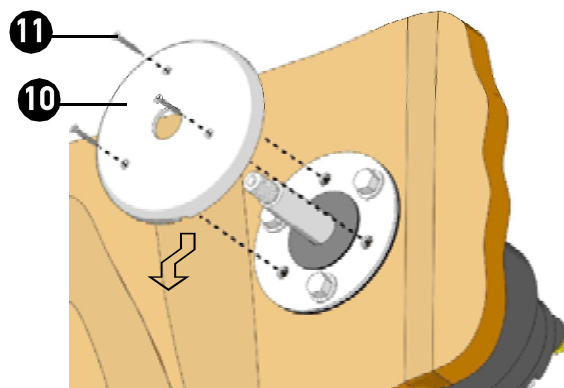

7 Position the steering wheel supplied separately (12) on the pump shaft (13) by using the suitable key (14). Insert the washer (15) and tighten the self-locking nut (16) with a 19 mm open end wrench and with a torque of 40 Nm (29.5 lb ft); then grease the thread by using some anti-seize grease MOLYKOTE® 1000 or a similar one.

⚠ CAUTION

If the self-locking nut (16) is disassembled, it must be replaced. (Contact our assistance service, see page 6).

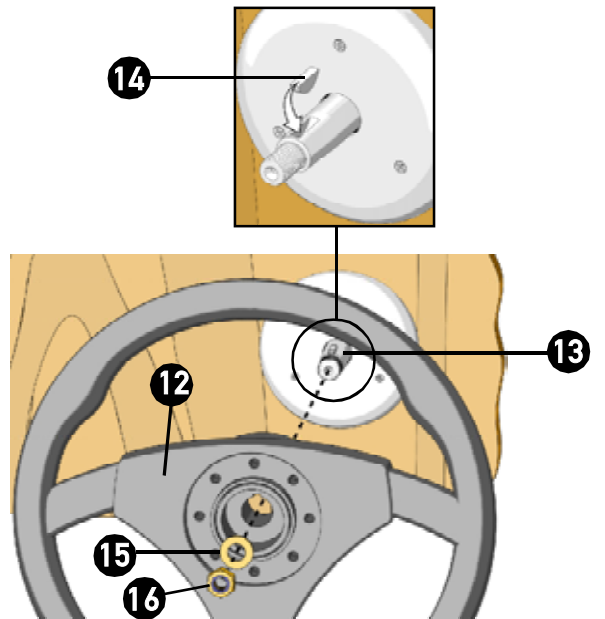

3.5 Tools necessary for the installation of pumps UP39-I R - UP45-I R



Loctite 542/545



MOLYKOTE® 1000



Torque wrench



Drill

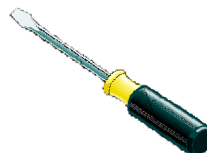

Screwdriver



Open end wrench 13 mm



Open end wrench 19 mm



Open end wrench 7/16"

3.6 Pumps UP39-I R - UP45-I R installation

1 Select a suitable place for the steering station. Make sure that there is enough manoeuvring space for the steering wheel and for the steering pump and its pipes and fittings.

⚠ WARNING

In order to fix the pump properly, the minimum dashboard thickness must be 25.4 mm [1 in.] and the maximum dashboard thickness must be 38.1 mm [1.5 in.]. Different thicknesses could compromise the driving safety.

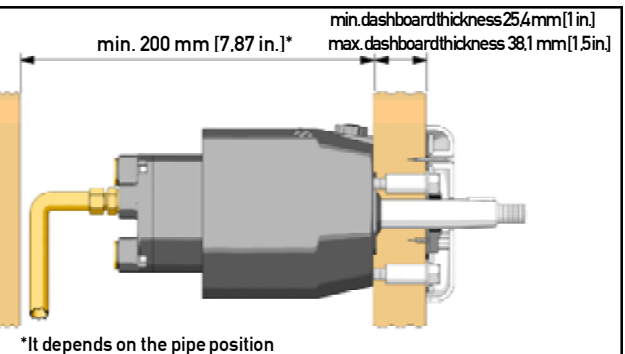

2 Remove the plugs (1) from the pump (2) by using a screwdriver.

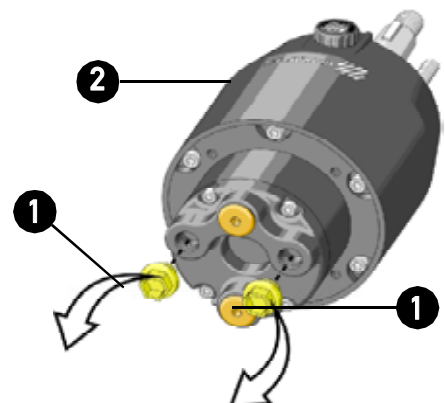

3 Put some fitting sealant type Loctite 542 or Loctite 545 on the thread. Fit and screw manually the conical fittings (3) until they are completely inserted; then tighten them with a 7/16" open end wrench with a torque of 17.6 Nm (156 lb ft).

⚠ WARNING

Do not use teflon tape or adhesive tape. Pay attention to the sealant positioning: if it is inserted into the system, it could block it and make it unusable.

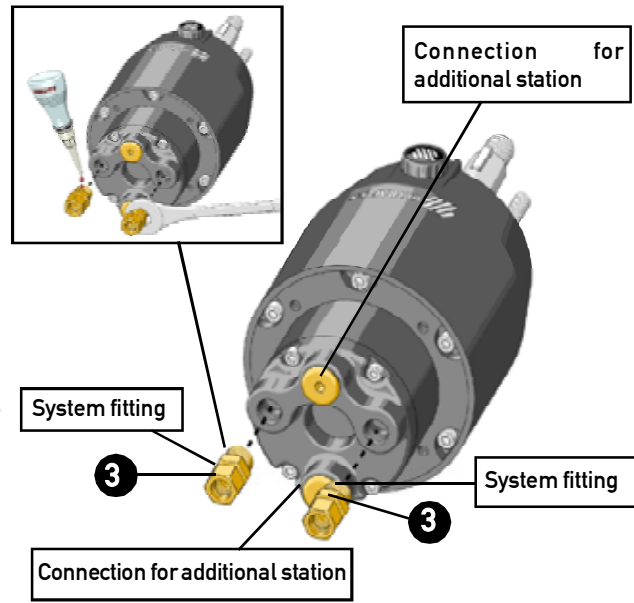

4 By using the proper template supplied with this manual, make the holes required by the installation in the suitable position on the dashboard.

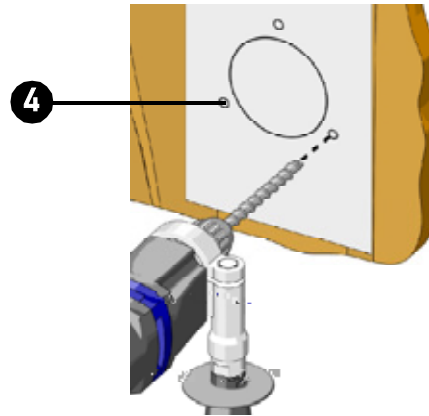

5 Position the pump (2) on the dashboard rear side (5). Then position the gasket (6) as shown in the picture and the flange (7) with the protective projecting part towards the dashboard outside. Fix the pump (2) with the 3 special screws (8) with a torque of 25 Nm (18.5 lb ft).

⚠ CAUTION

Make the shaft pass through the flange equipped with gasket by preventing the key seat from damaging the gasket itself.

⚠ WARNING

Install the pump by positioning the filling hole (9) towards the top (see the picture) for the right pump operation and to allow filling and purging the system completely (see par. 3.11).

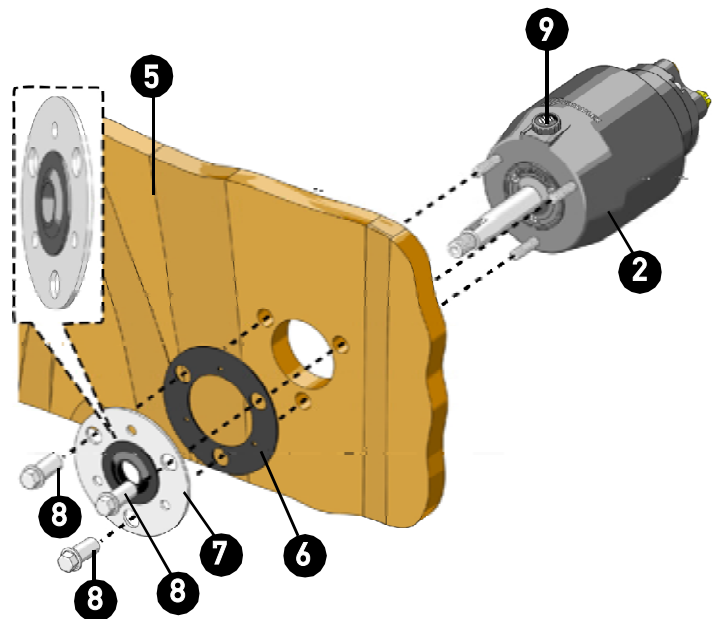

6 Position the plastic hub-cap (10) with the water discharge towards the bottom and fix it with the 3 self-tapping screws (11) supplied.

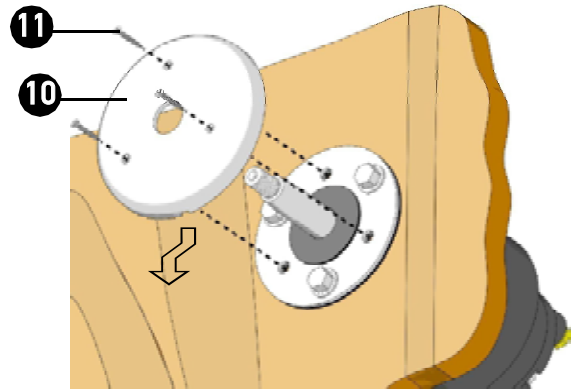

7 Position the steering wheel supplied separately (12) on the pump shaft (13) by using the suitable key (14). Insert the washer (15) and tighten the self-locking nut (16) with a 19 mm open end wrench and with a torque of 40 Nm (29.5 lb ft); then grease the thread by using some anti-seize grease MOLYKOTE® 1000 or a similar one.

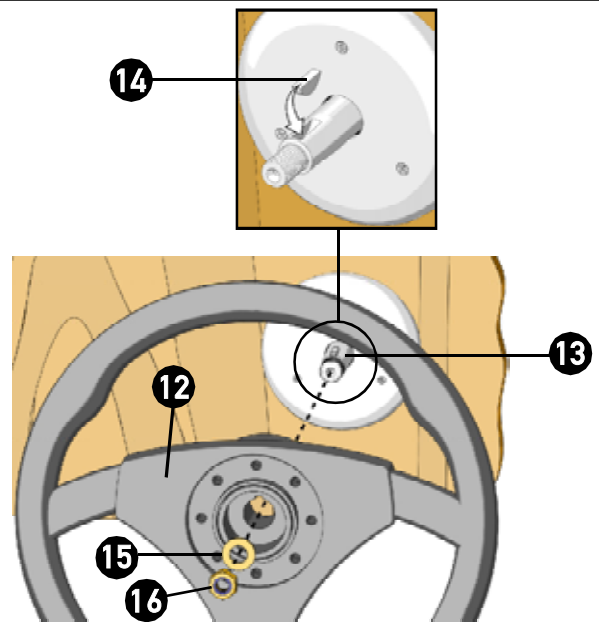

⚠ CAUTION

If the self-locking nut (16) is disassembled, it must be replaced. (Contact our assistance service, see page 6).

3.7 Tools necessary for the installation of pumps UP25 T - UP28 T - UP33 T - UP39 T - UP45 T



Open end wrench
11/16"

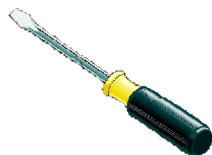

Screwdriver

* The tools to assemble tilt X52 are listed in the manual enclosed to tilt X52.

3.8 Pump UP25 T - UP28 T - UP33 T - UP39 T - UP45 T installation



⚠ CAUTION

The tilt X52 mechanism is supplied separately.

1 Select a suitable place for the steering station. Make sure that there is enough manoeuvring space for the steering wheel and for the steering pump and its pipes and fittings.

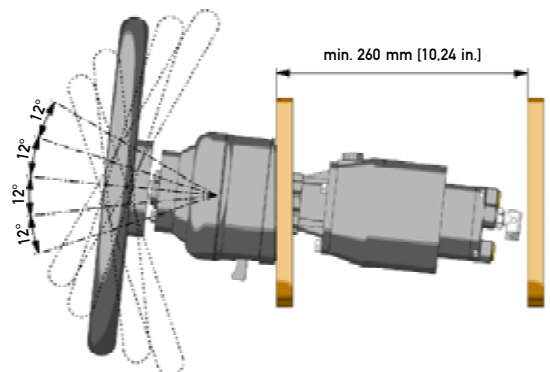

2 Remove the plugs (1) from the pump (2) by using a screwdriver.

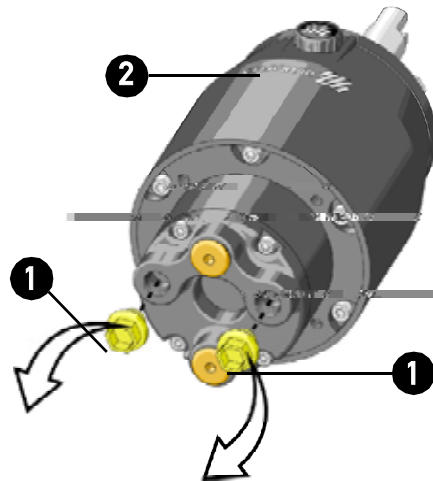

3 Fix the bracket (3) supplied with tilt X52 to the dashboard (4) by following the instructions enclosed to tilt X52.

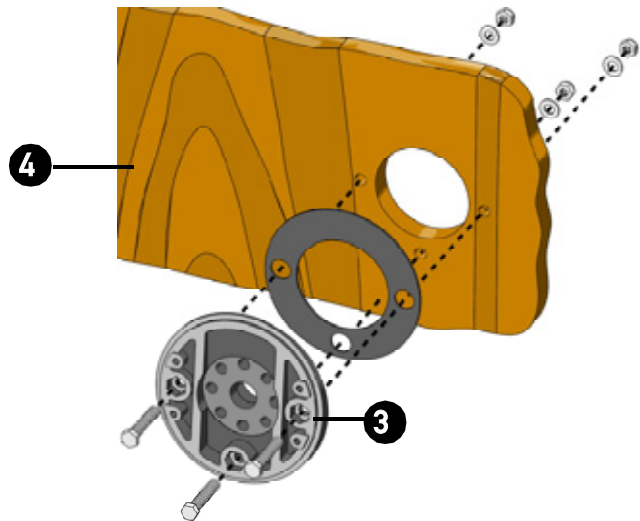

4 Screw the nuts completely on the corresponding 90° unions (3). Fit and screw the unions manually as indicated in the picture until they are inserted completely. Turn them until they are positioned correctly with respect to the pipes by unscrewing them no more than one revolution, then tighten the nuts with a 11/16" Allen wrench with a torque of 17.6 Nm (13 lb ft) until the washer touches the nut.

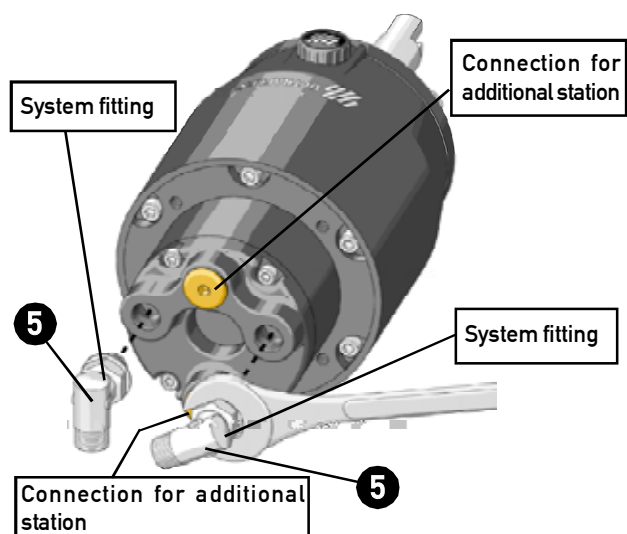

⚠ WARNING

DO NOT USE teflon tape or adhesive tape.
DO NOT PUT any thread sealant like Loctite 542 or similar products.



5 Fix the pump to the bracket (3) supplied with tilt X52 by using the 3 M8 screws (6) supplied with tilt X52 according to the instructions enclosed to tilt X52.

⚠ WARNING

Install the pump by positioning the filling hole (7) towards the top (see the picture) for the right pump operation and to allow filling and purging the system completely (see par. 3.11).

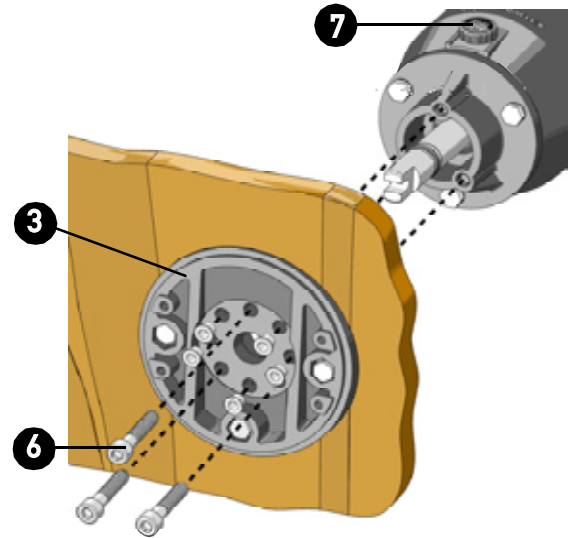

6 Align and insert the tilt universal joint into the pump shaft by loosening about 1-1.5 turns the screws (8) on the universal joint itself always according to the procedure described in the installation manual supplied with tilt X52. Retighten the screws (8) and fix the tilt.

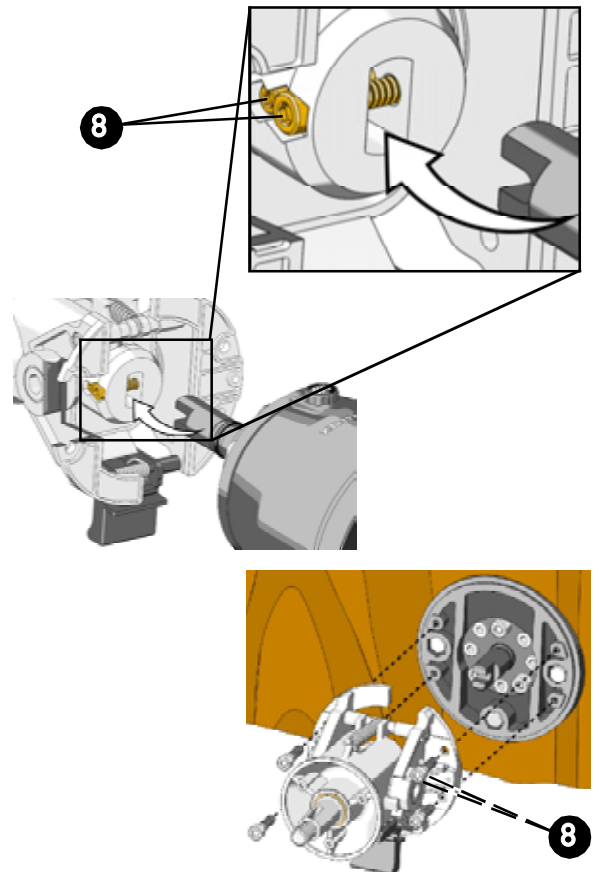

NOTICE

The kit **ULTRAFLEX** supplied separately (see the corresponding instructions) can be used on pumps UP28 R-UP33 R-UP39 R - UP39-I R - UP45 R - UP45-I R and UP25 T-UP28 T-UP33 T-UP39 T - UP45 T to simplify the hydraulic system filling and purging.



3.9 Types of installation



The pumps UP25-UP28-UP33-UP39-UP45 can be installed in a single or dual station (except the pumps series "NV") and they can be used with different types of front mount, side or inboard cylinder configurations. The pumps series "NV" cannot be used with unbalanced cylinders.

⚠ CAUTION

Connect hoses as shown in the installation and maintenance manual of the corresponding hydraulic cylinders.

MODELS UP 25 F-R-T, UP 28 F-R-T, UP 33 F-R-T, UP 39 F-R-T, UP 45 F-R-T

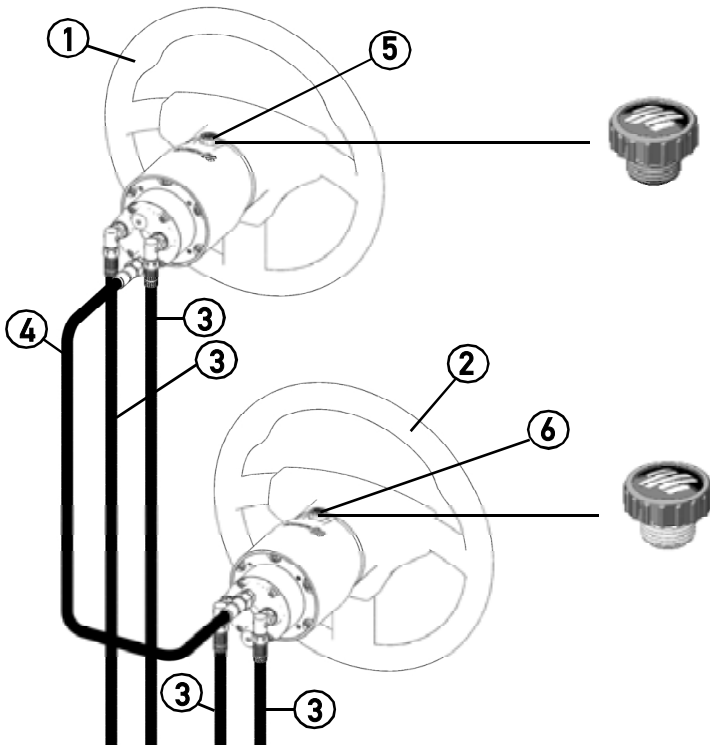

1. main steering station
2. additional steering station (not usable with pumps series "NV")
3. kit OB
4. 3/8" pipe included kit OB-2S
5. vent plug (black plug)
6. plug without vent (grey plug)

NOTICE

Kit OB-2S is supplied separately in case of applications with double station.

MODELS UP39-I R and UP 45-I R

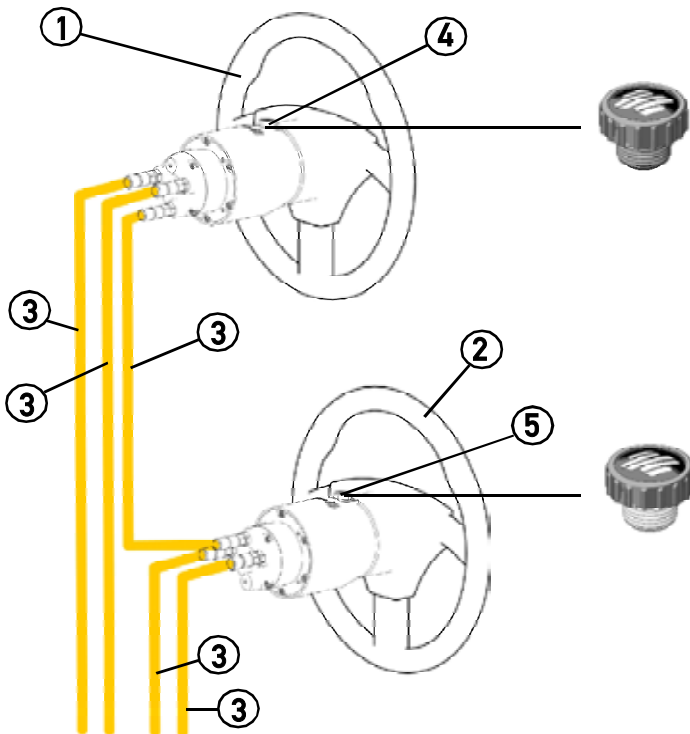

1. main steering station
2. additional steering station (not usable with pumps series "NV")
3. rigid metal pipe
4. vent plug (black plug)
5. plug without vent (grey plug)

NOTICE

Kit OB 120 U-2S is supplied separately in case of applications with double station.



3.10 Hose connection to the system

3.10.1 Hose connection to the system for models UP 25 F-R-T, UP 28 F-R-T, UP 33 F-R-T, UP 39 F-R-T, UP 45 F-R-T



ENGLISH

- 1 Connect the hydraulic hoses **ULTRAFLEX** kit OB (supplied separately) joining the pump and the cylinder by following the instructions given in the installation manual of the kit OB.
- 2 If one or more additional steering stations are installed (except the pumps series "NV"), use the kit OB-2S by following the suitable instructions.

Position 3/8" straight unions (1) on the pumps as indicated in the picture.

Put some fitting sealant type Loctite 542 or Loctite 545 on the thread. Fit and screw manually the fittings (1) until they are completely inserted; then tighten them with a 7/16" open end wrench with a torque of 17.6 Nm (156 lb ft).

⚠ WARNING

Do not use teflon tape or adhesive tape. Pay attention to the sealant positioning: if it is inserted into the system, it could block it and make it unusable.

MAIN STEERING STATION

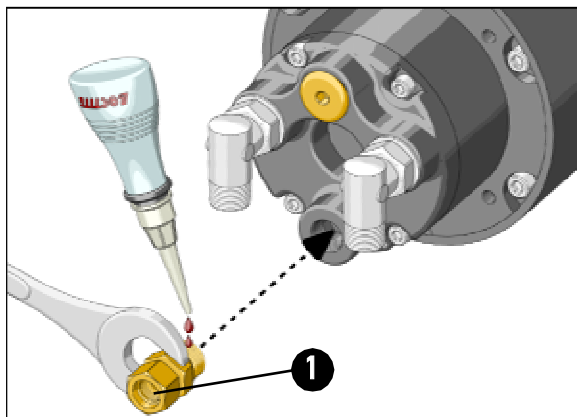

ADDITIONAL STEERING STATION

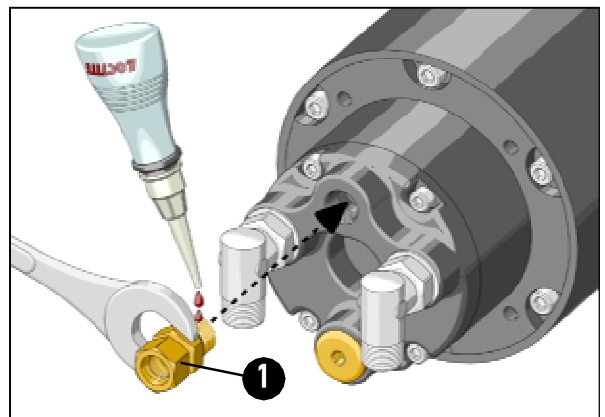

- 3 Connect pipes as shown in picture following the manual instructions.

MAIN STEERING STATION

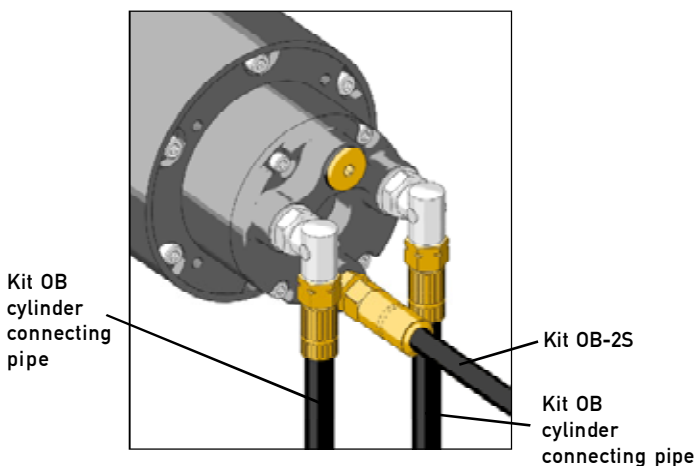

MAIN STEERING STATION

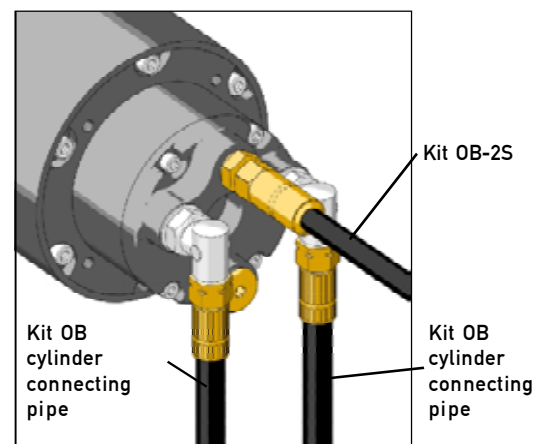

⚠ WARNING

Keep the pipes far from heat sources and from chemical substances. Protect the pipes that must pass through bulkheads by using suitable thru hulls. The bends must be perfectly smooth: any bent pipe or dent would prevent the hydraulic oil passage.

⚠ WARNING

Keep clean. Make sure that working areas are free from dust and dirt. The protective plugs of threaded holes must be removed only before the connection of fittings and pipes. Make sure that pipes are perfectly clean and free from swarf. If copper or steel pipes are used, cleaning is mandatory. If the installer uses pipes that are different from Kit OB, he must take full responsibility for it.

⚠ WARNING

At the end of the installation make sure that the pipes do not interfere with the engine and with fixed or mobile parts of the boat or of the steering system itself.

⚠ WARNING

The minimum bending radius of the pipes is 250 mm. Any excessive pipe bending could break them by compromising the good operation of the system. If necessary, replace the damaged pipe.

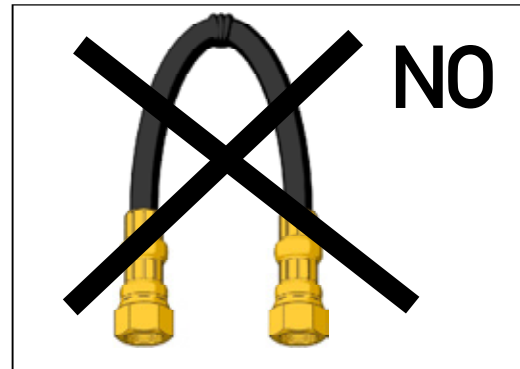
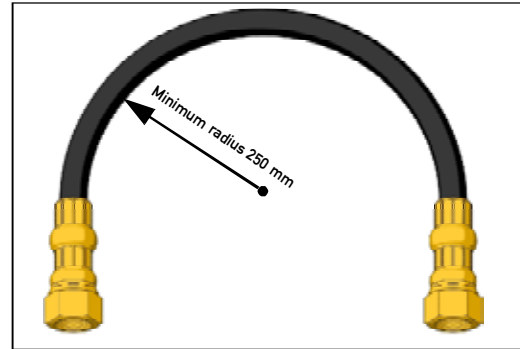

3.10.2 How to choose the rigid pipes for models UP39-I R and UP 45-I R



| PIPE MATERIAL: STEEL | SPECIFICATIONS | STRUCTURE | CONDITIONS | TOLERANCE BETWEEN EXT. DIAM./WALL THICKNESS | SURFACE |
|-----------------------------|--------------------|----------------------------|------------------------|---|---|
| St. 37.4 (=St 35.4, 1.0255) | DIN 2391/ DIN 1630 | Cold-drawn without welding | NBK, DIN 2391-2 | DIN 2391-1-C | Phosphated, lubricated or A3C (coated with zinc and yellow chromium-plated) |
| E 235 (= 1.0308) | EN 10305-4 | | +N (=normal annealed) | EN 10305-4 | |
| R37 | ISO 3304 | | NBK (=normal annealed) | ISO 3304 | |
| St 52.4 (= 1.0580) | DIN 2391 | | NBK, DIN 2391-2 | DIN 2391-1 | |
| E355 (= 1.0580) | EN 10305-4 | | +N (=normal annealed) | EN 10305-4 | |
| R50 | ISO 3304 | | NBK (=normal annealed) | ISO 3304 | |

| PIPE MATERIAL: STAINLESS STEEL | SPECIFICATIONS | STRUCTURE | CONDITIONS | TOLERANCE BETWEEN EXT. DIAM./WALL THICKNESS | SURFACE |
|--------------------------------|-------------------------|----------------------------|-------------------------|---|----------------------------------|
| 1.4571 (= TP 316 Ti) | DIN 2391 | Cold-drawn without welding | Soft annealed DIN 17458 | DIN 2391-1 | Smooth |
| 1.4541 (= TP 321) | | | Soft annealed | D4/T3 (EN ISO 1127) | |
| 1.4404 (= TP 316L) | EN ISO 1127 o Astm A269 | | | | |
| 1.4301 (= TP 304) | | EN ISO 1127 | Weld-in pipe | DIN 17457-K2 for 6-12 mm ext. diam., cold-drawn welded (CDW) with smooth external surface for 14-42 mm ext. diam. | Smooth, almost invisible welding |
| 1.4401 (= TP 316) | | | | | |
| 1.4301 (= TP 304) | | | | | |
| 1.4541 (= TP 321) | | | | | |

| PIPE MATERIAL: COPPER | SPECIFICATIONS | STRUCTURE | CONDITIONS | TOLERANCE BETWEEN EXT. DIAM./WALL THICKNESS | SURFACE |
|-----------------------|----------------|---------------|------------|---|------------------|
| R 290 | EN 1057 | Weldless pipe | EN 1057 | EN 1057 | Clean and smooth |



NOTICE

This table is only indicative.

ULTRAFLEX cannot be held responsible for the pipe choice, since the installer must do this according to the operating pressure.

⚠ WARNING

ULTRAFLEX UP Series pumps are provided with a valve protecting them against overpressure when the pressure is higher than about 70 bar (1000 PSI).

The references to the standards are updated at the date of issue of this document. The installer must make sure that there are no other updates.



3.10.3 Hose connection to the system for models UP39-I R and UP45-I R

- 1 Connect the rigid pipes (12 mm external diameter) to connect the pump to the cylinder.
- 2 If one or more additional steering stations are installed (except the pumps series "NV"), use the kit OB 120 U-2S by following the suitable instructions.

Position 3/8" straight unions (1) as indicated in the picture.

Put some fitting sealant type Loctite 542 or Loctite 545 on the thread. Fit and screw manually the fittings (3) until they are completely inserted; then tighten them with a 7/16" open end wrench with a torque of 17.6 Nm (156 lb ft).

⚠ WARNING

Do not use teflon tape or adhesive tape. Pay attention to the sealant positioning: if it is inserted into the system, it could block it and make it unusable.

MAIN STEERING STATION

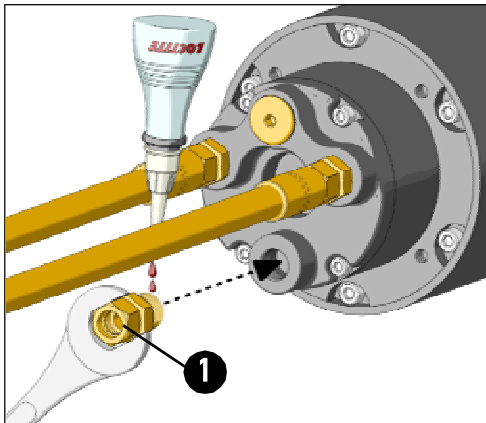

ADDITIONAL STEERING STATION

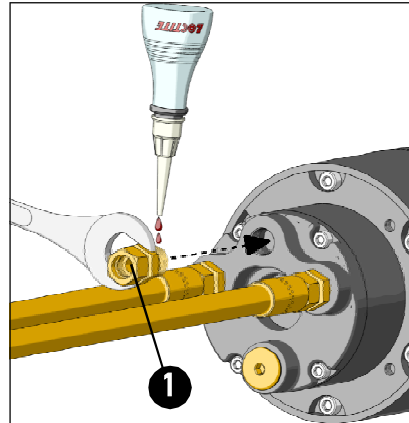

- 3 Connect pipes as shown in picture and tighten them with a proper torque according to the pipe manufacturer specifications.

MAIN STEERING STATION

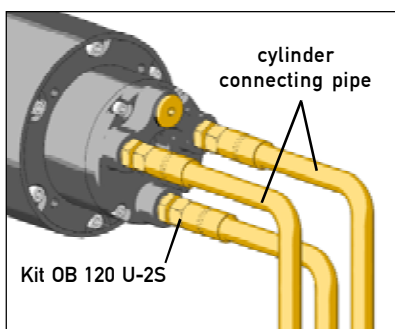

ADDITIONAL STEERING STATION

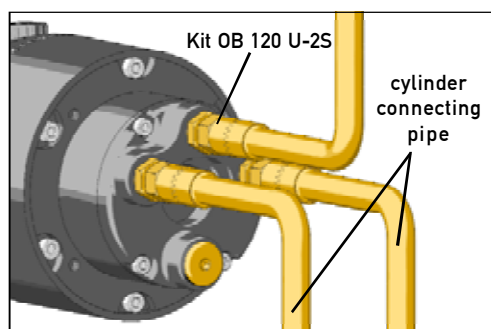

NOTICE

Kit OB 120 U-2S is supplied separately for applications with double station and it includes all the necessary unions for 12 mm copper pipe.

The copper pipe must be bought separately.

⚠ DANGER

The unions assembled on the pump are NOT swinging. If they are unscrewed they get broken and the pump cannot be used anymore.

NOTICE

The rigid pipe assembly (cutting, bending and bulkhead passage) must be carried out by skilled staff according to the manufacturer's instructions. In case of copper or steel pipes flushing is compulsory.

3.11 Filling and purging

After the first installation and after maintenance operations it is necessary to fill the system with hydraulic oil. This operation must avoid the air in the system, to ensure the good system operation. The hydraulic system must be filled from the highest point of the system, which means from the upper steering station.

⚠ CAUTION

To avoid air bubbles in the oil, it is necessary to fill the tank slowly.

⚠ WARNING

The filling and bleeding operations must be carried out at least by two operators

NOTICE

The filling and purging operations can be facilitated by using the automatic purging equipment BUBBLE BLUSTER® (supplied separately).

⚠ DANGER

Use **ULTRAFLEX** oil or other compatible oils.

Hydraulic oil OL150 has been specifically formulated for **ULTRAFLEX** to ensure high quality performance level of **ULTRAFLEX** products throughout time.

Its special "Zinc Free" formula enhances protection against marine oxidation. The special mix of anti-wear and stabilizing components of OL150 allow ensuring great results as far as the product duration and performances are concerned in several environmental conditions. **ULTRAFLEX** hydraulic oil complies with standard ISO 10592 concerning hydraulic steering systems. **ULTRAFLEX** is not to be held responsible for any damages or performance deterioration if oils different from OL150 are used.

⚠ DANGER

Do NOT use ATF Dexron II transmission oils or brake oils which could cause the steering system seizing.

Oils which are compatible with OL150 **ULTRAFLEX** are:

- Shell Tellus T15 and Shell Tellus T22
- Mobil DTE 11M

NOTICE

ULTRAFLEX will not be able to ensure the compatibility of the above mentioned oils with OL150 if the oil manufacturers vary their formulation; in particular, it will not be able to ensure its compliance with standard ISO 10592 concerning hydraulic steering systems. Under no circumstances **ULTRAFLEX** is to be held responsible for any damages or performance deterioration.

In the days after the filling, check the oil level; if necessary top off the system.

At the beginning the oil level can lower, as small amounts of air can be released in a homogeneous way. According to the types of installation, it is necessary to carry out the different bleeding procedures, as it follows.



3.11.1 Positioning of the oil bottle

To carry out this operation, it is necessary to use the oil filling kit (1 needle, 1 transparent pipe, 1 pipe connection and 1 spout for the oil bottle). This kit is NOT supplied.

- Remove the pump cap and insert the fittings.
- Attach the spout to a new bottle of hydraulic oil and connect the hose to the fittings and the bottle spout.
- Turn the bottle upside down and pierce it with the pin, as shown in the picture, to ease the oil passage towards the pump. Fill the pump until no air bubbles are visible in the hose.

⚠ WARNING

While replacing the oil bottle, during the filling process, close all the bleed valves of the cylinder/s. To bleed the system, check that oil is always present in the filling hose. If some air is in the system during the bleeding process, the whole bleeding process must be started again.

⚠ CAUTION

Replace the bottle before it empties and use recovered oil only after 24 hours.

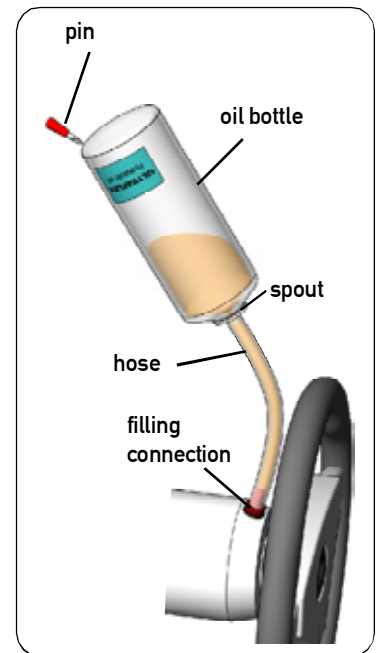

3.11.2 Purging procedure

NOTICE

Carry out the purging procedure as indicated in the installation and maintenance manual of the cylinder used. Then check that the oil level is suitable by turning 1/2 turn the steering wheel and by making the oil come out of the bleed valve. Close the valve and check the system.

3.12 General recommendation

⚠ WARNING

It is very important to check the absence of air in the system before using the boat! We recommend trying to manually move the engine/s or the helm/s towards port and starboard, making sure that there is no movement of the cylinder body on the main cylinder shaft.

If the cylinder body moves too much, there is still air in the system. The air presence in the system can cause bad responses to the controls and so it can cause damage, injuries or death.

⚠ WARNING

Check the system response by moving the pump.

⚠ DANGER

After 24 hours repeat the purging and make sure there are no leaks.



4 SAFETY WARNINGS

This section shows the safety rules which must be followed for the correct equipment operation. We recommend reading carefully this section and also the other manuals supplied with the steering system components.

4.1 Safety warnings during use and installation

RESPECT STRICTLY the following safety rules.

ULTRAFLEX declines all responsibility in case the user does not follow these rules and it is not responsible for negligence during the use of the system.

DANGER

- **DO NOT PUT HANDS BETWEEN THE MOVING PARTS.**
- Do not disable the safety devices.
- Do not modify or add devices to the system, without **ULTRAFLEX** written authorisation or technical intervention which will prove the modification.
- Do not use the equipment for a purpose different from the one it has been designed for, which is specified in the installation and maintenance manual.
- Do not let non-specialized staff perform the installation.
- Do not disassemble the hydraulic connections before bleeding the oil in the system completely. The hoses can contain high pressure oil.
- In case of installation with double station DO NOT use both stations. As a matter of fact the two stations are always enabled on the steering compartment. The effect of the rudden rotation on both stations will double causing an undesired manoeuvre.

WARNING

- Do not put the feet on the cylinder.
- Check the system after the installation and the purging but before operating the vessel. Turn the steering wheel until the cylinder/s reaches/reach the end stroke. Turn the steering wheel to the opposite direction. Repeat on each installed helm to verify the correct installation and the system operation.
- Carefully use sealing fluid (such as Loctite). If it reaches the hydraulic system, it may cause damage and mechanical failure.
- Do not use teflon tape or adhesive tape to seal the fittings, as this material may be injected, by causing the system fail.
- During the system installation, prevent foreign matters from entering the system. Even a little object may cause lasting damage that are not detected immediately.
- Avoid too narrow bend radius of hoses.
- Avoid the hose contact with edges or sharp corners.
- Avoid the hose contact with heat sources.

4.2 Clothing

WARNING

During installation, inspection or maintenance, IT IS STRICTLY FORBIDDEN to wear necklaces, bracelets or clothes which could get caught in the moving parts.

5 MAINTENANCE

5.1 Ordinary maintenance

⚠ WARNING

Poor installation and maintenance may result in loss of steering and cause property damage and/or personal injury. Maintenance requirements change according to climate, frequency and the use. Inspections are necessary at least every year and must be carried out by specialized marine mechanics. Check the cylinder fittings and the seals and the helm gaskets to prevent leaks. Replace them if necessary.

To keep a suitable oil level in the tank, fill and bleed the system as described in this manual in paragraph 3.11 and in the bleeding procedure of **ULTRAFLEX** cylinders. Check the hose and the entire system wear, the nut and bolt tightening every six months and make sure that they are not damaged. Clean the system using water and non-abrasive soap.

⚠ DANGER

Use only compatible hydraulic oils, indicated in the paragraph "technical features" and "filling and purging". Do not use brake oils or automatic transmission fluid (ATF) in any case.

⚠ CAUTION

If the self-locking nuts are disassembled, they must be replaced. (Contact our assistance service, see page 6).

5.2 Steering wheel disassembly

To remove the steering wheel from the pump shaft, use a suitable extractor.

⚠ WARNING

Do not use a hammer or other tools that could seriously damage the pump.

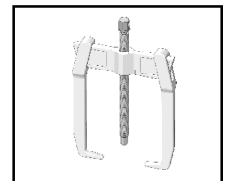

5.3 Troubleshooting

⚠ WARNING

Whenever the following checks need the removal and/or disassembly of the steering system components, such work must be carried by specialized staff. **ULTRAFLEX** offers general information only and is not responsible for any consequences resulting from incorrect disassembly.

| PROBLEM | CAUSE | SOLUTION |
|---|---|--|
| During the filling, the steering system becomes completely jammed. | <ul style="list-style-type: none"> Blockage in the hoses between steering system and cylinder. | <ul style="list-style-type: none"> Replace hoses. <p>⚠ DANGER</p> <p>The damaged hose must be replaced, otherwise it may cause loss of steering and severe personal injury or property damage.</p> |
| The system is very difficult to fill. Air keeps bubbling at the top of the steering system tank even after filling the system completely. | <ul style="list-style-type: none"> Air in the system. | <ul style="list-style-type: none"> Repeat the filling and the bleeding procedure of the system. Install horizontally the hoses and in any case with a maximum inclination of 3cm each meter. |
| | <ul style="list-style-type: none"> Leaks from the cylinder bleeder. | <ul style="list-style-type: none"> Tighten the bleeder on the cylinder. |
| | <ul style="list-style-type: none"> Coiled hose. | <ul style="list-style-type: none"> Uncoil and straighten the hose. |
| | <ul style="list-style-type: none"> Helm has been mounted upside down. | <ul style="list-style-type: none"> Mount the helm with the filling hole in up position. |



| | | |
|--|--|--|
| The steering system is stiff and hard to turn, even when the boat is not moving. | • Restrictions in hoses or fittings. | • Look for and remove the restriction. |
| | • Air in oil. | • Repeat the filling and the bleeding procedure of the system. |
| The steering system is stiff and hard to turn, even when the boat is not moving. | • Wrong oil has been used. | • Drain the filling and bleeding system. |
| | | ⚠ WARNING ULTRAFLEX is not responsible for damage caused by fluids that are not recommended in this manual and so the warranty is cancelled. |
| The steering system is stiff and hard to turn, even when the boat is not moving, if unbalanced cylinders are used. | • Dirt in the valve. | ⚠ WARNING Do not use the boat and contact a specialized technician for the valve cleaning. |
| | | |
| The steering system is easy to turn at the dock but becomes hard to turn when the boat is in motion. | • The steering wheel is too small. | • Replace the steering wheel with a bigger one. |
| | • Incorrect setting of the torque tab. | ⚠ WARNING • Only within the maximum dimensions allowed by the helm. |
| | • Air in oil. | • Adjust the torque tab. • Check the oil level and repeat the bleeding procedure as explained in this manual. |
| When the steering wheel is turned, the rod (movable rod cylinders) or the body (fixed cylinder rod) of the cylinder do not move. | • Air in the system. | • Repeat the filling and bleeding procedure of the system. |
| | • Oil leak. | • Look for the leak and contact specialized staff. |
| | • Helm mounted upside down. | • Mount the helm with the filling hole in up position. |
| Leaks from steering system fittings. | • Bad tightening or low torque of the fittings. | • Tighten the fittings with a maximum torque of 20Nm (15 in.lbs). |
| | • Lack of fitting sealant. ⚠ WARNING Never use teflon tape or adhesive tape on any fitting. | • Drain and disassemble the steering system. Remove the fittings and remove the oil from threads. Put the sealant on the fittings and tighten them, install the helm. ⚠ WARNING After this operation it is necessary to carry out another bleeding. |
| Leaks from the tank plug. | • Bad tightening of the plug. | • Tighten the plug. |
| | • The vent plug on the additional helm is in the lower position. | • Replace the vent plug with the plug for the additional helm kit. |
| | • Worn and damaged seal. | • Replace the plug. |
| | • Too high oil level. | • Follow the procedure to maintain the suitable oil level, which is described in the pump manual. |



6 DISMANTLING

6.1 Dismantling

When for any reason, the steering system is put out of service, it is necessary to follow some rules in order to respect the environment.

Sheaths, pipelines, plastic or non-metallic components must be disassembled and disposed of separately.

*The steering system **CONTAINS POLLUTING OILS**
which must be disposed of according to the rules in force in the country.*

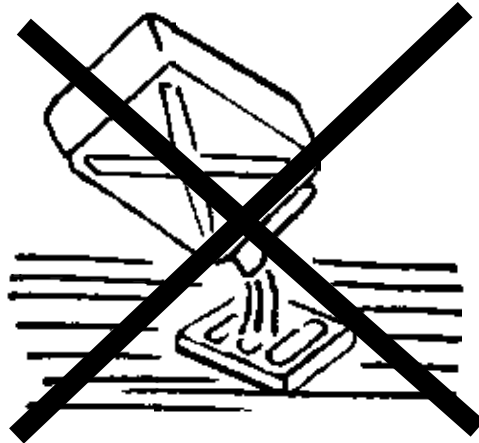

NOTES

ENGLISH

Manuale d'installazione e manutenzione

POMPA PER SISTEMI DI GUIDA IDRAULICI

UP25 F
UP28 F
UP33 F
UP39 F
UP45 F
UP25NV F
UP33NV F

UP28 R
UP33 R
UP39 R
UP39-I R
UP45 R
UP45-I R

UP25 T
UP28 T
UP33 T
UP39 T
UP45 T

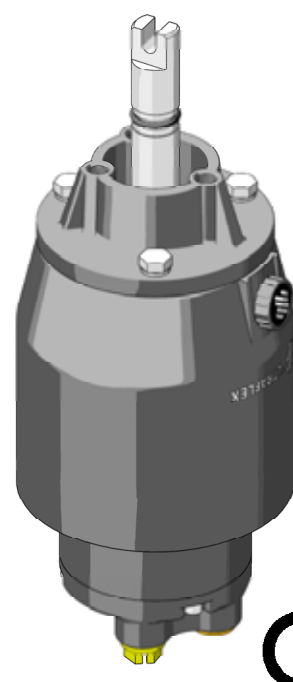
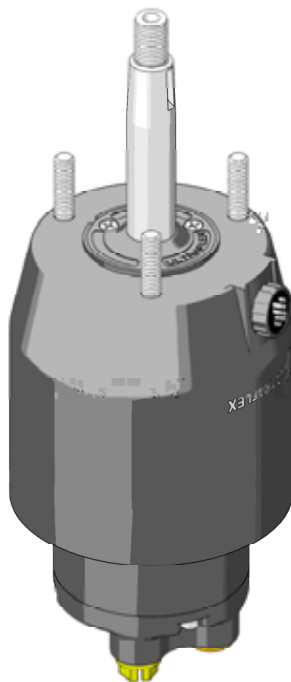

CE



ULTRAFLEX

ITALIANO



SOCIO



ULTRAFLEX

Gentile Cliente,

La ringraziamo per aver scelto un prodotto **ULTRAFLEX**.

ULTRAFLEX è da anni un punto di riferimento nei sistemi di guida nel settore della nautica da diporto e professionale.

Da sempre la produzione **ULTRAFLEX** è sinonimo di grande affidabilità e sicurezza.

Tutti i prodotti **ULTRAFLEX** sono progettati e prodotti per garantire sempre le prestazioni migliori, relativamente allo scopo per cui sono concepiti.

Per tutelare la Vostra sicurezza e per mantenere sempre un alto livello qualitativo **ULTRAFLEX** garantisce i propri prodotti solo se utilizzati con i ricambi originali.

I Sistemi di Gestione Qualità **ULTRAFLEX** ed **UFLEX** sono certificati CISQ-IQNet dal RINA Registro Italiano Navale, in conformità alla Norma UNI EN ISO 9001:2008. Certificato **ULTRAFLEX** n° 6669/02/S (già 420/96). Certificato **UFLEX** n°8875/03/S.

Il sistema Qualità coinvolge tutte le risorse ed i processi aziendali a partire dalla progettazione, per:

- garantire al cliente la qualità del prodotto;
- impostare le azioni per mantenere e migliorare nel tempo gli standard di qualità;
- perseguire un continuo miglioramento dell'efficacia e dell'efficienza dei processi per poter essere sempre in sintonia con le esigenze del mercato ed accrescere la soddisfazione dei Clienti.

Il sistema di Gestione Ambientale Ultraflex è certificato da CISQ-IQNet dal RINA Registro Italiano Navale, in conformità alla Norma UNI EN ISO 14001. Certificato **ULTRAFLEX** n° EMS-1282/S.

I prodotti destinati alla nautica da diporto vengono costantemente controllati per verificare la rispondenza ai requisiti imposti dalla direttiva 2013/53/UE.



"**ULTRAFLEX**, con più di 80 anni di esperienza nel settore nautico è oggi leader globale nella produzione di sistemi di guida meccanici, idraulici ed elettronici, scatole di comando e volanti per imbarcazioni a motore da diporto, da pesca o da lavoro di ogni dimensione e tipo di motorizzazione.

L'affidabilità dei nostri prodotti ed il servizio ante e post vendita, la qualità dell'organizzazione aziendale e delle risorse umane insieme agli investimenti continui in ricerca e sviluppo sono fattori determinanti per spiegare il successo crescente dei nostri prodotti ovunque nel mondo".

ULTRAFLEX S.p.A.

16015 Casella (Genova) Italia - Via Crose, 2

INDICE GENERALE



| | |
|--|----|
| INDICE DELLE REVISIONI DEL DOCUMENTO | 38 |
| USO DEL MANUALE E SIMBOLOGIA IMPIEGATA | 39 |
| LETTERA INFORMATIVA | 40 |
| GARANZIA | 40 |

SEZIONE 1 - DESCRIZIONE DEL PRODOTTO



| | |
|--|----|
| 1.1 FUNZIONAMENTO DI UN SISTEMA DI GUIDA IDRAULICO | 41 |
| 1.2 AVVERTENZE PER IL CORRETTO UTILIZZO DEL PRODOTTO | 41 |
| 1.3 CONFIGURAZIONI DEL SISTEMA | 42 |
| 1.4 DESCRIZIONE DELLE POMPE | 42 |
| 1.5 CARATTERISTICHE TECNICHE DELLE POMPE | 43 |

SEZIONE 2 - TRASPORTO



| | |
|-------------------------------|----|
| 2.1 AVVERTENZE GENERALI | 46 |
| 2.2 CONTENUTO IMBALLO | 46 |

SEZIONE 3 - INSTALLAZIONE



| | |
|--|----|
| 3.1 UTENSILI NECESSARI PER INSTALLAZIONE POMPE UP25 F - UP28 F - UP33 F - UP39 F - UP45 F - UP25NV F - UP33NV F .. | 49 |
| 3.2 INSTALLAZIONE DELLE POMPE UP25 F - UP28 F - UP33 F - UP39 F - UP45F - UP25NV F - UP33NV F ... | 49 |
| 3.3 UTENSILI NECESSARI PER INSTALLAZIONE POMPE UP28 R - UP33 R - UP39 R - UP45 R | 51 |
| 3.4 INSTALLAZIONE DELLE POMPE UP28 R - UP33 R - UP39 R - UP45 R | 51 |
| 3.5 UTENSILI NECESSARI PER INSTALLAZIONE POMPE UP39 I R - UP45 I R | 53 |
| 3.6 INSTALLAZIONE DELLE POMPE UP39 I R - UP45 I R | 53 |
| 3.7 UTENSILI NECESSARI PER INSTALLAZIONE POMPE UP25 T - UP28 T - UP33 T - UP39 T - UP45 T | 55 |
| 3.8 INSTALLAZIONE DELLE POMPE UP25 T - UP28 T - UP33 T - UP39 T - UP45 T | 55 |
| 3.9 TIPI DI INSTALLAZIONE | 58 |
| 3.10 COLLEGAMENTO DEI TUBI ALL'IMPIANTO | 59 |
| 3.10.1 COLLEGAMENTO DEI TUBI ALL'IMPIANTO MODELLI UP25 F-R-T, UP28 F-R-T, UP33 F-R-T, UP39 F-R-T, UP45 F-R-T | 59 |
| 3.10.2 SCELTA DEI TUBI RIGIDI PER MODELLI UP39 I R - UP 45 I R | 60 |
| 3.10.3 COLLEGAMENTO DEI TUBI ALL'IMPIANTO MODELLI UP45 I R | 61 |
| 3.11 RIEMPIMENTO E SPURGO | 62 |
| 3.11.1 POSIZIONAMENTO DELLA BOTTIGLIA DELL'OLIO | 63 |
| 3.11.2 PROCEDURA DI SPURGO | 63 |
| 3.12 RACCOMANDAZIONE GENERALE | 63 |

SEZIONE 4 - AVVERTENZE DI SICUREZZA



| | |
|--|----|
| 4.1 NORME DI SICUREZZA DURANTE L'INSTALLAZIONE E L'USO | 64 |
| 4.2 ABBIGLIAMENTO | 64 |

SEZIONE 5 - MANUTENZIONE



| | |
|----------------------------------|----|
| 5.1 MANUTENZIONE ORDINARIA | 65 |
| 5.2 SMONTAGGIO VOLANTE | 65 |
| 5.3 RICERCA GUASTI | 65 |

SEZIONE 6 - SMANTELLAMENTO



| | |
|--------------------------|----|
| 6.1 SMANTELLAMENTO | 67 |
|--------------------------|----|

INDICE DELLE REVISIONI DEL DOCUMENTO

| Rev. | Data | Descrizione della revisione |
|------|------------|--|
| 0 | 24/09/2008 | Prima realizzazione |
| 1 | 20/11/2012 | Aggiunta modelli 45 F - R - I R - T e modifica raccordi orientabili |
| 2 | 30/07/2013 | Aggiunta modello 39-I R |
| 3 | 28/02/2014 | Errata corrige riferimenti figure pagine 42 e 43 |
| 4 | 16/07/2014 | Modifica capitoli "Contenuto imballo" e "Posizionamento della bottiglia dell'olio" |

USO DEL MANUALE E SIMBOLOGIA IMPIEGATA

IL MANUALE DI INSTALLAZIONE E MANUTENZIONE è il documento che accompagna il prodotto dal momento della sua vendita fino alla sua sostituzione e smaltimento. Risulta cioè essere parte integrante dello stesso. E' richiesta la lettura del manuale prima che venga intrapresa QUALSIASI ATTIVITA' che coinvolga il prodotto compresa la movimentazione e lo scarico dello stesso dal mezzo di trasporto.

Al fine di tutelare la sicurezza dell'utilizzatore e per garantire il corretto funzionamento del prodotto nel presente manuale è stata adottata la simbologia di seguito descritta.

 **PERICOLO** → Danni immediati che CAUSANO ferite gravi alla persona o che portano alla morte.

 **AVVERTENZA** → Indica che esiste un pericolo che può causare lesione o morte se non sono adottate le precauzioni appropriate.

 **ATTENZIONE** → Indica un richiamo all'applicazione di pratiche di sicurezza oppure richiama l'attenzione su pratiche non sicure che potrebbero causare lesione personale o danno all'imbarcazione o ai componenti o all'ambiente.

NOTA → Informazione ritenuta importante per una installazione adeguata e per la manutenzione, che non è causa di danni.

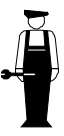
 → Le operazioni per la cui esecuzione si richiede, onde evitare possibili rischi, personale qualificato o specializzato sono evidenziate con il simbolo indicato a lato. Si raccomanda di formare il personale destinato all'installazione del prodotto e di verificare che quanto previsto sia compreso ed attuato.

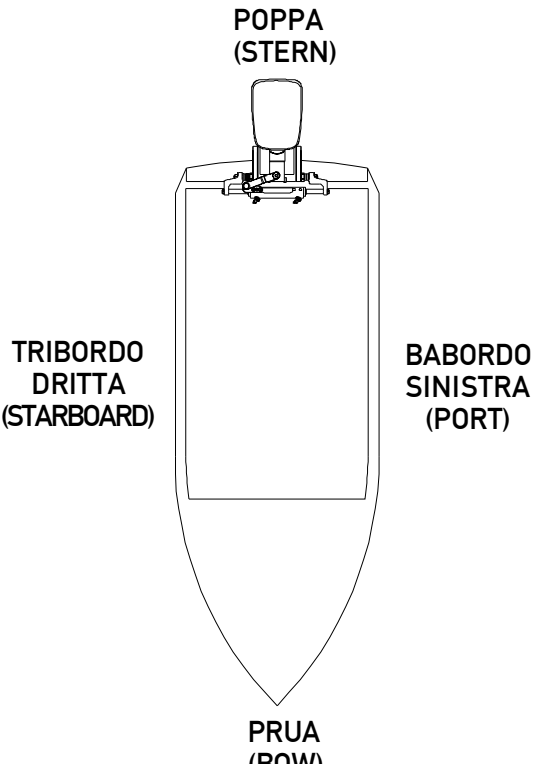

POPPA
(STERN)

PRUA
(BOW)

TRIBORDO
DRITTA
(STARBOARD)

BABORDO
SINISTRA
(PORT)

→ La figura a lato ha la funzione di facilitare l'interpretazione di alcuni termini nautici contenuti nel presente manuale.

LEGENDA

m.p.h. = miglia/ora
km/h = chilometri/ora

10 m.p.h. = 8,69 nodi
10 m.p.h. = 16,1 km/h
10 nodi = 11,5 m.p.h.
10 nodi = 18,5 km/h
10 km/h = 6,21 m.p.h.
10 km/h = 5,4 nodi



LETTERA INFORMATIVA

Il presente manuale di installazione e manutenzione costituisce parte integrante del prodotto e deve essere facilmente reperibile dal personale addetto all'uso e alla manutenzione dello stesso.

L'utilizzatore è tenuto a conoscere il contenuto del presente manuale.

ULTRAFLEX declina ogni responsabilità per eventuali inesattezze dovute ad errori di stampa, contenute nel manuale.

Ferme restando le caratteristiche essenziali del prodotto descritto, **ULTRAFLEX** si riserva il diritto di apportare eventuali modifiche di descrizioni, dettagli e illustrazioni, che riterrà opportune per il miglioramento dello stesso, o per esigenze di carattere costruttivo o commerciale, in qualunque momento e senza impegnarsi ad aggiornare tempestivamente questa pubblicazione.

TUTTI I DIRITTI SONO RISERVATI. I diritti di pubblicazione, i marchi, le sigle e le fotografie dei prodotti **ULTRAFLEX** presenti in questo manuale sono di proprietà **ULTRAFLEX** che ne vieta qualsiasi riproduzione anche parziale. Ogni cura è stata posta nella raccolta e nella verifica della documentazione per rendere questo manuale il più completo e comprensibile possibile. Nulla di quanto contenuto nella presente pubblicazione può essere interpretato come garanzia o condizione espressa o implicita - inclusa, non in via limitativa, la garanzia di idoneità per un particolare scopo. Nulla di quanto contenuto nella presente pubblicazione può inoltre essere interpretato come modifica o asserzione dei termini di qualsivoglia contratto di acquisto.

⚠ AVVERTENZA

Al fine di assicurare il corretto funzionamento del prodotto e dei suoi componenti, lo stesso deve essere installato da personale esperto. In caso di rotture di parti componenti o malfunzionamento, rivolgersi a personale specializzato o contattare il nostro Servizio Assistenza Tecnica.

SERVIZIO ASSISTENZA TECNICA

UFLEX S.r.l.

Via Milite Ignoto,8A
16012 Busalla (GE)-Italia
Tel: +39.010.962.01
Fax: +39.010.962.0333
Email: ut@ultraflexgroup.it
www.ultraflexgroup.it

Nord - Sud - Centro America: UFLEX USA

6442 Parkland Drive
Sarasota, FL 34243
Ph: +1.941.351.2628
Fax: +1.941.360.9171
Email: uflex@uflexusa.com
www.uflexusa.com

GARANZIA

ULTRAFLEX garantisce che i suoi prodotti sono costruiti a regola d'arte e che sono privi di difetti di fabbricazione e di materiali.

Questa garanzia è valida per un periodo di due anni decorrenti dalla data di fabbricazione dei prodotti ad eccezione dei casi in cui questi siano installati ed usati su barche da lavoro o comunque su barche ad utilizzo commerciale, nel qual caso la garanzia è limitata ad 1 anno dalla data di fabbricazione.

Questa garanzia è limitata alla sostituzione o riparazione gratuita del pezzo che, entro il termine suddetto, ci sarà restituito in porto franco e che rileveremo essere effettivamente difettoso nei materiali o/e nella fabbricazione.

È escluso dalla garanzia ogni e qualsiasi altro danno diretto o indiretto. In particolare, è escluso dalla garanzia e da ogni nostra responsabilità (tranne quella di sostituire o riparare, nei termini e condizioni suddette, i pezzi difettosi) il malfunzionamento dei nostri prodotti qualora il loro mancato o difettoso funzionamento sia attribuibile ad una errata installazione o ad uso negligente o improprio.

Questa garanzia non copre i prodotti installati su barche da corsa o utilizzate in contesti competitivi. Le descrizioni e le illustrazioni di questo manuale s'intendono fornite a titolo indicativo.

Per informazioni dettagliate si prega di contattare il nostro Servizio Assistenza.

I componenti dei sistemi di guida **ULTRAFLEX** sono marcati **CE** come richiesto dalla direttiva 2013/53/EU.

Vi ricordiamo che sulle imbarcazioni marcate CE è obbligatorio installare sistemi di guida i cui componenti siano marcati CE. Vi informiamo che la garanzia **ULTRAFLEX** decade automaticamente qualora alcuni componenti **ULTRAFLEX** siano installati in un sistema di guida insieme a prodotti di altre marche.



1 DESCRIZIONE DEL PRODOTTO

1.1 Funzionamento di un sistema di guida idraulico

I sistemi idraulici di guida **ULTRAFLEX** sono progettati in conformità alla normativa UNI-EN-ISO 10592 ed alla A.B.Y.C. P21.

I sistemi di guida **ULTRAFLEX** sono in grado di operare in un campo di temperatura ambiente compreso tra -18°C (0°F) e $+77^{\circ}\text{C}$ ($+170^{\circ}\text{F}$), tutti i loro componenti sono stati realizzati specificatamente per l'ambiente marino, utilizzando materiali e processi di fabbricazione che offrono grande durata e sicurezza anche nelle condizioni più estreme. Il sistema di guida idraulico in una imbarcazione è schematicamente costituito da una pompa posta sul cruscotto, da un cilindro posizionato a poppa e collegato al motore o al timone e dai tubi idraulici di collegamento (vedi figura). La rotazione del volante provoca il pompaggio dell'olio che, a seconda del senso di rotazione, affluisce attraverso i tubi al cilindro.

Il conseguente movimento del cilindro fa defluire l'olio verso la pompa attraverso i tubi e nello stesso tempo sposta il motore o il timone dell'imbarcazione collegati al cilindro stesso. Le pompe dotate di una valvola di non ritorno, che ha la funzione d'impedire il flusso dell'olio alla pompa se questa non viene azionata, rendono possibile il funzionamento dei sistemi con due o più stazioni di guida. Le pompe serie "NV" non sono dotate di valvola di non ritorno pertanto non possono essere usate con due o più stazioni di guida. I cilindri sono a doppia azione e possono essere bilanciati o non bilanciati. Nei cilindri non bilanciati le due camere hanno volumi differenti e pertanto richiedono, a parità di spostamento nei due sensi, un diverso numero di giri del volante e un diverso sforzo di rotazione sul volante. I cilindri non bilanciati non possono essere utilizzati con le pompe serie "NV". I cilindri bilanciati richiedono lo stesso numero di giri del volante per spostare il timone da centro a fine corsa nelle due direzioni opposte. Un sistema di guida equilibrato e facilmente manovrabile richiede una corretta scelta del tipo di pompa da accoppiare al cilindro. **ULTRAFLEX** costruisce diversi modelli di pompe, che differiscono per la portata (cm^3 di olio movimentati ad ogni giro del volante) e per il tipo di installazione. Quando si sceglie la pompa bisogna considerare il volume del cilindro. Il numero di giri del volante da sinistra a destra è infatti determinato dal rapporto tra il volume del cilindro e la portata della pompa.

Esempio: se la pompa ha una portata di 28 cm^3 [1,7cu.in.] e il cilindro ha un volume di 120 cm^3 [7,3cu.in.] si applica la formula: $120/28=4,2$. Il volante pertanto ruoterà circa 4 volte prima che il cilindro sia completamente spostato da una parte all'altra. Nel caso di installazioni con due cilindri connessi in parallelo occorre sommare il volume dei cilindri. Non sono raccomandabili accoppiamenti con meno di 4 giri, che richiedono un'eccessiva forza di guida, o più di 8 giri che rendono lenta la risposta dell'imbarcazione alla timoneria.

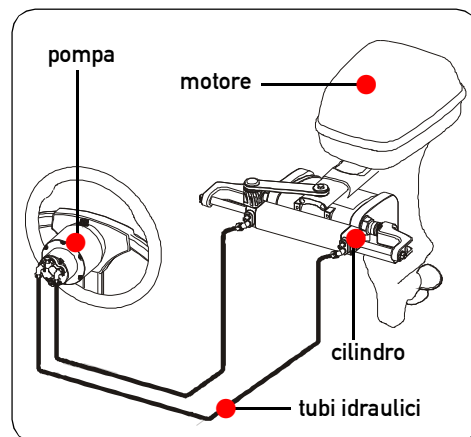

1.2 Avvertenze per il corretto utilizzo del prodotto

⚠ PERICOLO

In qualsiasi caso non modificare la pompa per adattarla alla vostra applicazione. In questo caso la pompa non opererà in sicurezza e metterà in pericolo l'imbarcazione e i suoi occupanti.

⚠ AVVERTENZA

I sistemi di guida **ULTRAFLEX** non devono essere applicati su imbarcazioni equipaggiate con motorizzazioni che superano le potenze massime installabili stabilite dal cantiere.

⚠ AVVERTENZA

I sistemi di guida idraulici **ULTRAFLEX** non sono consigliati per installazioni su barche da corsa.

⚠ AVVERTENZA

Le pompe UP25NV F e UP33NV F non possono essere usate con cilindri non bilanciati e non possono essere usate con doppia stazione.



1.3 Configurazioni del sistema

Le pompe modello UP25 - UP28 - UP33 - UP39 - UP45 possono essere installate in un sistema di guida singolo o doppio e utilizzate in accoppiamento a diversi tipi di configurazioni di cilindri a montaggio frontale, laterale o entrobordo.

Le pompe serie "NV" non possono essere installate in un sistema di guida doppio e non possono essere utilizzate in accoppiamento a cilindri non bilanciati.

⚠ ATTENZIONE

Eseguire sempre con attenzione l'esatto collegamento dei tubi come indicato nei manuali di installazione e manutenzione dei relativi cilindri idraulici.

1.4 Descrizione delle pompe

Le pompe UP25 - UP28 - UP33 - UP39 - UP45 sono state progettate e costruite per essere utilizzate come componenti di un sistema di guida idraulico come descritto nel paragrafo precedente.

Le pompe UP25 F - UP28 F - UP33 F - UP39 F - UP45 F - UP25NV F - UP33NV F devono essere montate sulla parte frontale del cruscotto dell'imbarcazione o a semi incasso tramite le flange X64 o X57 (fornite a parte), le pompe UP28 R - UP33 R - UP39 R - UP39-I R - UP45 R - UP45-I R devono essere montate sulla parte posteriore del cruscotto dell'imbarcazione, le pompe UP25 T - UP28 T - UP33 T - UP39 T - UP45 T devono essere montate tramite il tilt X52 (fornito a parte).

Le figure di seguito mostrano i componenti principali delle pompe:

- | | |
|--|--|
| <p>1 Pompa UP25 F - UP28 F - UP33 F - UP39 F - UP 45 F - UP25NV F - UP33NV F</p> <p>2 Tappo serbatoio con sfiato</p> <p>3 Albero per collegamento volante</p> <p>4 Collegamenti per connessione al/i cilindro/i</p> <p>5 Collegamenti per connessioni stazioni supplementari (non utilizzabili con la serie "NV")</p> | <p>6 Grani M6 per fissaggio a cruscotto</p> <p>7 Pompa UP28 R - UP33 R - UP39 R - UP39-I R - UP45 R - UP45-I R</p> <p>8 Grani M8 per fissaggio a cruscotto</p> <p>9 Pompa UP25 T - UP28 T - UP33 T - UP39 T - UP45 T</p> <p>10 Albero connessione al tilt X52</p> |
|--|--|

UP25 F - UP28 F - UP33 F - UP39 F - UP45 F - UP25NV F - UP33NV F

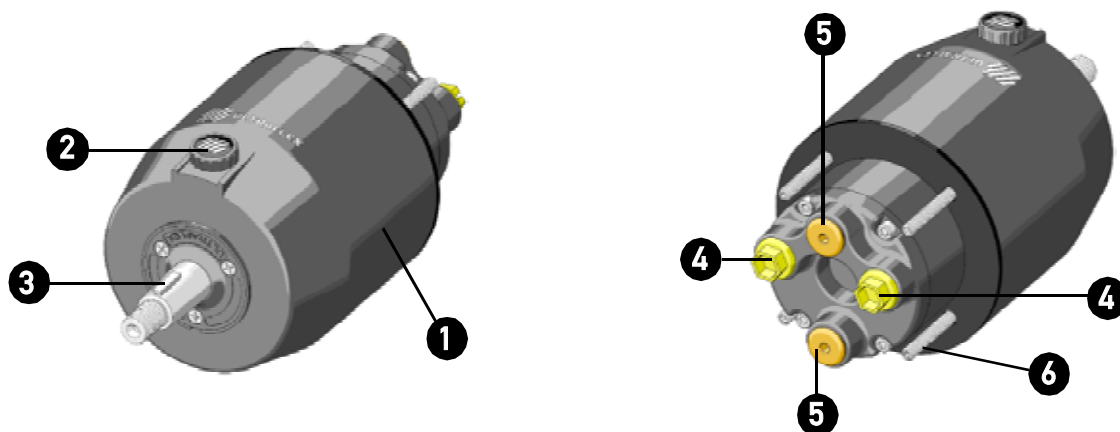

UP28 R - UP33 R - UP39 R - UP39-I R - UP45 R - UP45-I R

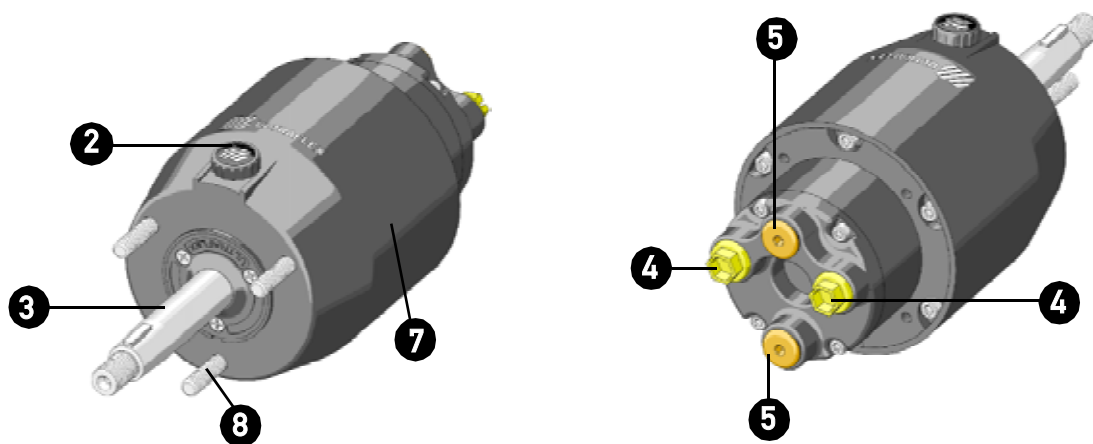

UP25 T - UP28 T - UP33 T - UP39 T - UP45 T

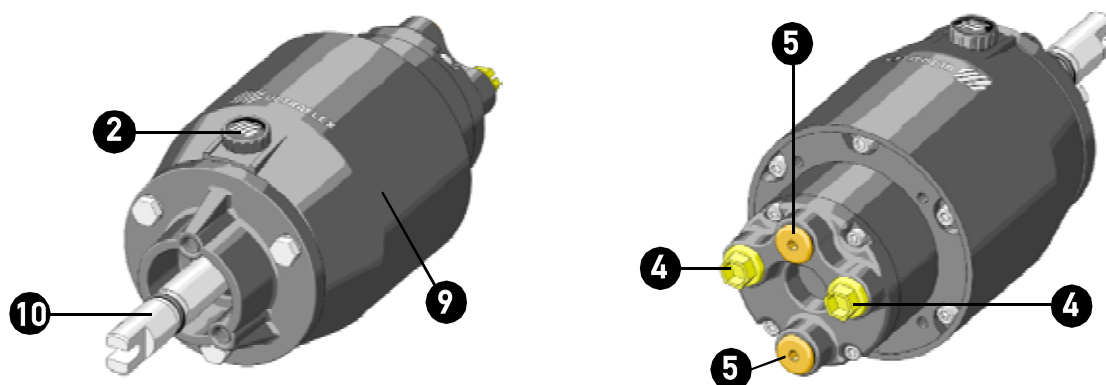

1.5 Caratteristiche tecniche delle pompe

| SPECIFICHE | POMPA UP25 F | POMPA UP25NV F | POMPA UP28 F | POMPA UP33 F | POMPA UP33NV F | POMPA UP39 F | POMPA UP45 F |
|--|-------------------------------|-------------------------------|-----------------------------|-----------------------------|-----------------------------|-----------------------------|-----------------------------|
| Portata | 23,5 cc/giro - 1,4 cu.in/giro | 23,5 cc/giro - 1,4 cu.in/giro | 28 cc/giro - 1,7 cu.in/giro | 33 cc/giro - 2,0 cu.in/giro | 33 cc/giro - 2,0 cu.in/giro | 39 cc/giro - 2,4 cu.in/giro | 45 cc/giro - 2,7 cu.in/giro |
| Pressione di rilascio delle valvole di massima pressione | 70 bar (1000 psi) | 70 bar (1000 psi) | 70 bar (1000 psi) | 70 bar (1000 psi) | 70 bar (1000 psi) | 70 bar (1000 psi) | 70 bar (1000 psi) |
| N° pistoni | 5 | 5 | 5 | 7 | 7 | 7 | 7 |
| Diametro max. volante | 711 mm (28 in.) | 711 mm (28 in.) | 711 mm (28 in.) | 711 mm (28 in.) | 711 mm (28 in.) | 711 mm (28 in.) | 711 mm (28 in.) |
| Altezza max. volante | 152 mm (6 in.) | 152 mm (6 in.) | 152 mm (6 in.) | 152 mm (6 in.) | 152 mm (6 in.) | 152 mm (6 in.) | 152 mm (6 in.) |
| Peso | 5 kg (11 lbs) | 5 kg (11 lbs) | 5 kg (11 lbs) | 5 kg (11 lbs) | 5 kg (11 lbs) | 5 kg (11 lbs) | 5 kg (11 lbs) |
| Olio | OL150 Ultraflex | OL150 Ultraflex | OL150 Ultraflex | OL150 Ultraflex | OL150 Ultraflex | OL150 Ultraflex | OL150 Ultraflex |

⚠ ATTENZIONE

La pressione di rilascio delle valvole di massima pressione non corrisponde a quella di normale utilizzo del sistema ma rappresenta la condizione limite di utilizzo.



UP25 F - UP28 F - UP33 F - UP39 F - UP45 F - UP25NV F - UP33NV F

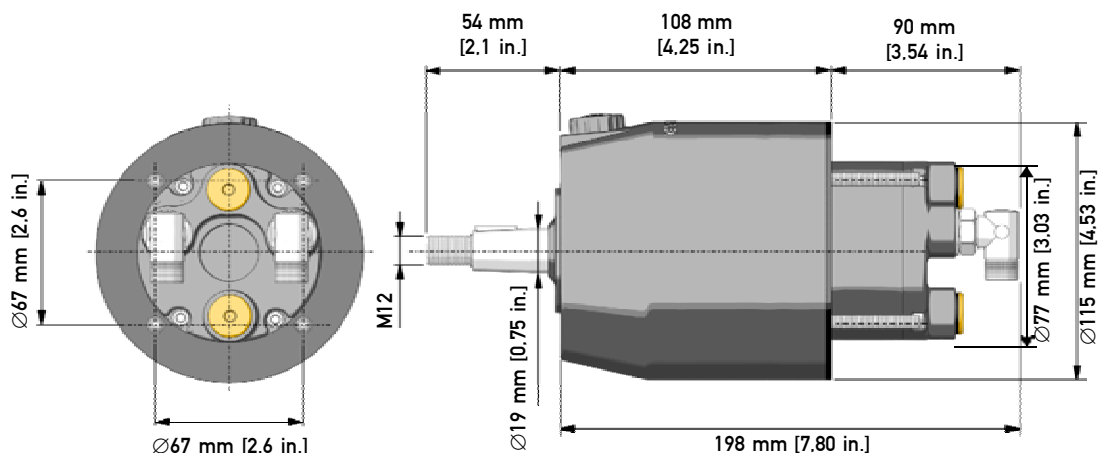

| SPECIFICHE | POMPA UP28 R | POMPA UP33 R | POMPA UP39 R | POMPA UP45 R | POMPA UP45-I R |
|--|-------------------------------|-------------------------------|-------------------------------|-------------------------------|-------------------------------|
| Portata | 28 cc/ giro - 1,7 cu.in./giro | 33 cc/ giro - 2,0 cu.in./giro | 39 cc/ giro - 2,4 cu.in./giro | 45 cc/ giro - 2,7 cu.in./giro | 45 cc/ giro - 2,7 cu.in./giro |
| Pressione di rilascio delle valvole di massima pressione | 70 bar (1000 psi) | 70 bar (1000 psi) | 70 bar (1000 psi) | 70 bar (1000 psi) | 70 bar (1000 psi) |
| N° pistoni | 5 | 7 | 7 | 7 | 7 |
| Diametro max. volante | 711 mm (28 in.) | 711 mm (28 in.) | 711 mm (28 in.) | 711 mm (28 in.) | 711 mm (28 in.) |
| Altezza max. volante | 152 mm (6 in.) | 152 mm (6 in.) | 152 mm (6 in.) | 152 mm (6 in.) | 152 mm (6 in.) |
| Peso | 5 kg (11 lbs) | 5 kg (11 lbs) | 5 kg (11 lbs) | 5 kg (11 lbs) | 5 kg (11 lbs) |
| Olio | OL150 Ultraflex | OL150 Ultraflex | OL150 Ultraflex | OL150 Ultraflex | OL150 Ultraflex |

⚠ ATTENZIONE

La pressione di rilascio delle valvole di massima pressione non corrisponde a quella di normale utilizzo del sistema ma rappresenta la condizione limite di utilizzo.

UP28 R - UP33 R - UP39 R - UP45 R

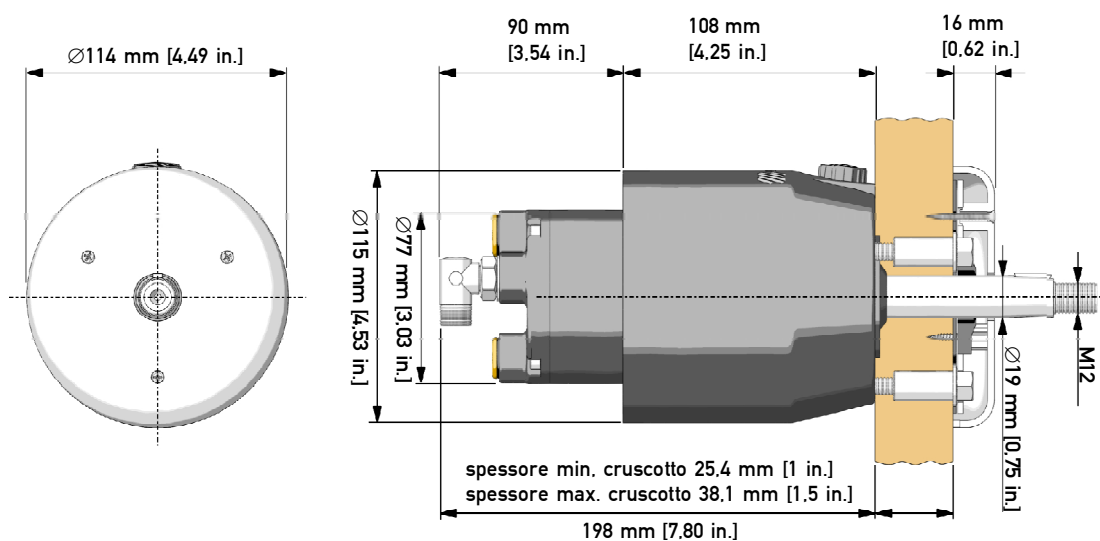

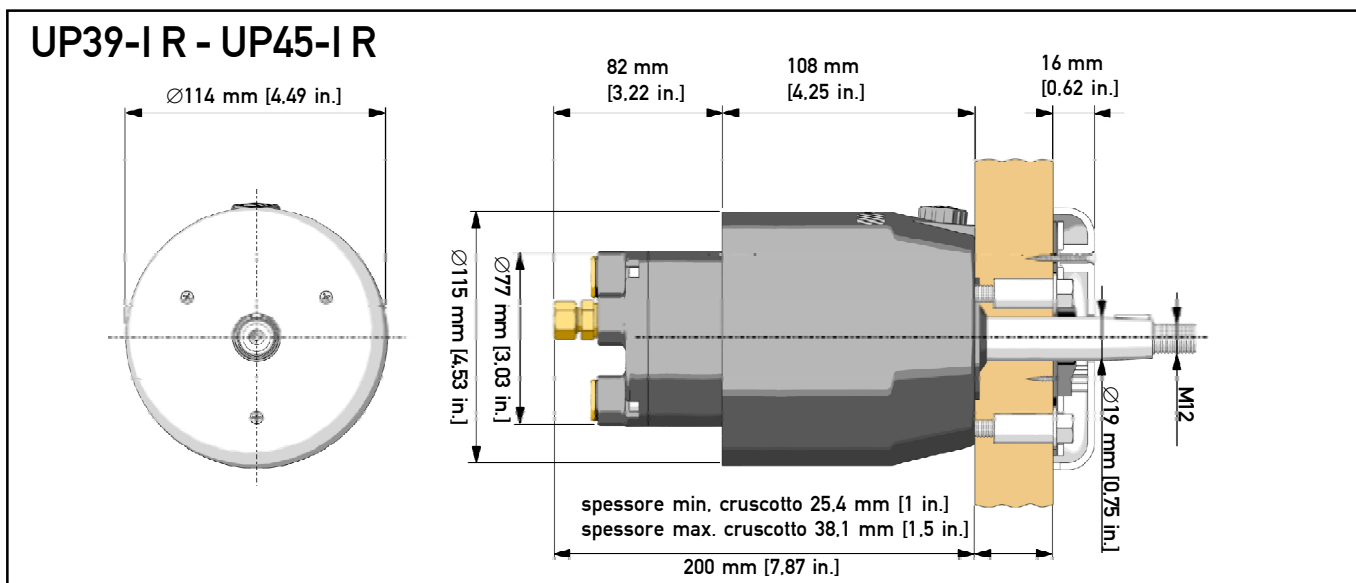

| SPECIFICHE | POMPA UP25 T | POMPA UP28 T | POMPA UP33 T | POMPA UP39 T | POMPA UP45 T |
|--|-----------------------------|-----------------------------|-----------------------------|-----------------------------|-----------------------------|
| Portata | 25 cc/giro - 1,5 cu.in/giro | 28 cc/giro - 1,7 cu.in/giro | 33 cc/giro - 2,0 cu.in/giro | 39 cc/giro - 2,4 cu.in/giro | 45 cc/giro - 2,7 cu.in/giro |
| Pressione di rilascio delle valvole di massima pressione | 70 bar (1000 psi) | 70 bar (1000 psi) | 70 bar (1000 psi) | 70 bar (1000 psi) | 70 bar (1000 psi) |
| N° pistoni | 5 | 5 | 7 | 7 | 7 |
| Diametro max. volante | 406 mm (16 in.) | 406 mm (16 in.) | 406 mm (16 in.) | 406 mm (16 in.) | 406 mm (16 in.) |
| Altezza max. volante | 152 mm (6 in.) | 152 mm (6 in.) | 152 mm (6 in.) | 152 mm (6 in.) | 152 mm (6 in.) |
| Peso | 5 kg (11 lbs) | 5 kg (11 lbs) | 5 kg (11 lbs) | 5 kg (11 lbs) | 5 kg (11 lbs) |
| Olio | OL150 Ultraflex | OL150 Ultraflex | OL150 Ultraflex | OL150 Ultraflex | OL150 Ultraflex |

⚠ ATTENZIONE

La pressione di rilascio delle valvole di massima pressione non corrisponde a quella di normale utilizzo del sistema ma rappresenta la condizione limite di utilizzo.

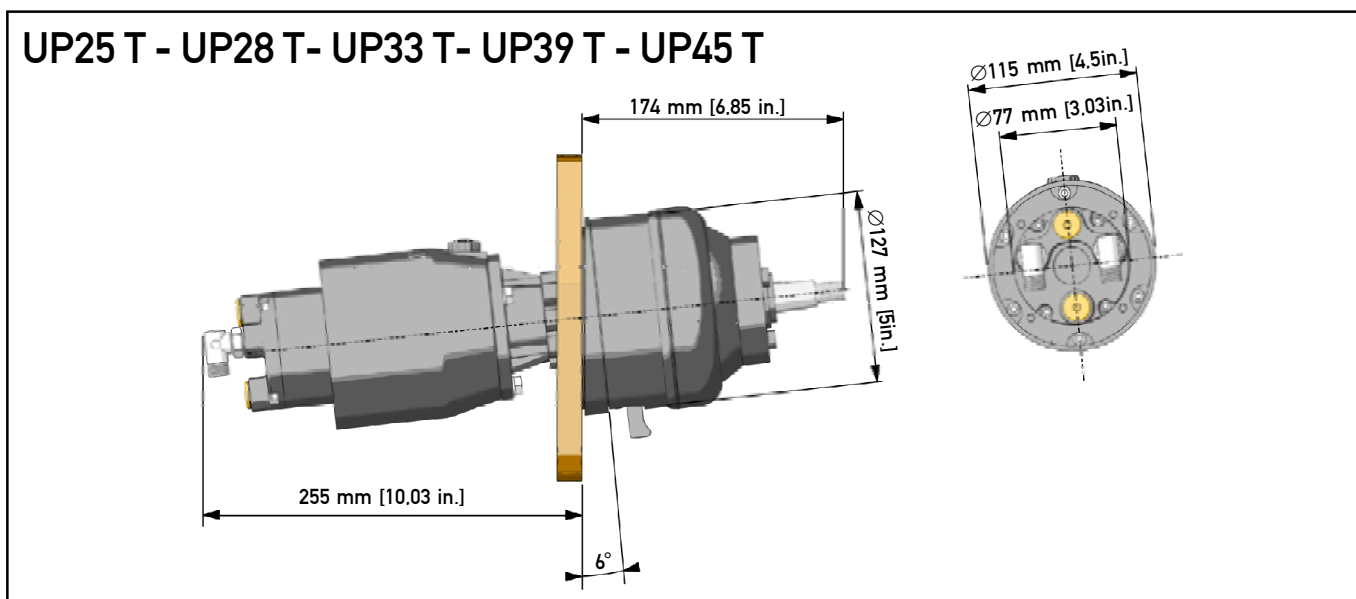

⚠ ATTENZIONE

Le pompe UP25 T - UP28 T - UP33 T - UP39 T - UP45 T possono essere utilizzate solo con il tilt **ULTRAFLEX X52** (fornito a parte).



2 TRASPORTO

2.1 Avvertenze generali

Il peso delle pompe UP25-UP28-UP33-UP39-UP45 con il loro imballo è 5 Kg (11 pounds). La loro movimentazione può quindi essere effettuata manualmente.

⚠ AVVERTENZA

Il personale addetto alla manipolazione del carico deve operare con guanti protettivi e scarpe anti infortunistiche.

2.2 Contenuto imballo

Prima dell'utilizzo dell'apparecchiatura verificare che non abbia subito danneggiamenti dovuti al trasporto o alle condizioni di conservazione. Verificare inoltre che tutti i componenti forniti di serie siano contenuti nell'imballo (vedi elenco). In caso di danneggiamento, notificare il reclamo allo spedizioniere ed avvisare il vostro fornitore.

UP25 F - UP28 F - UP33 F - UP39 F - UP45 F - UP25NV F - UP33NV F

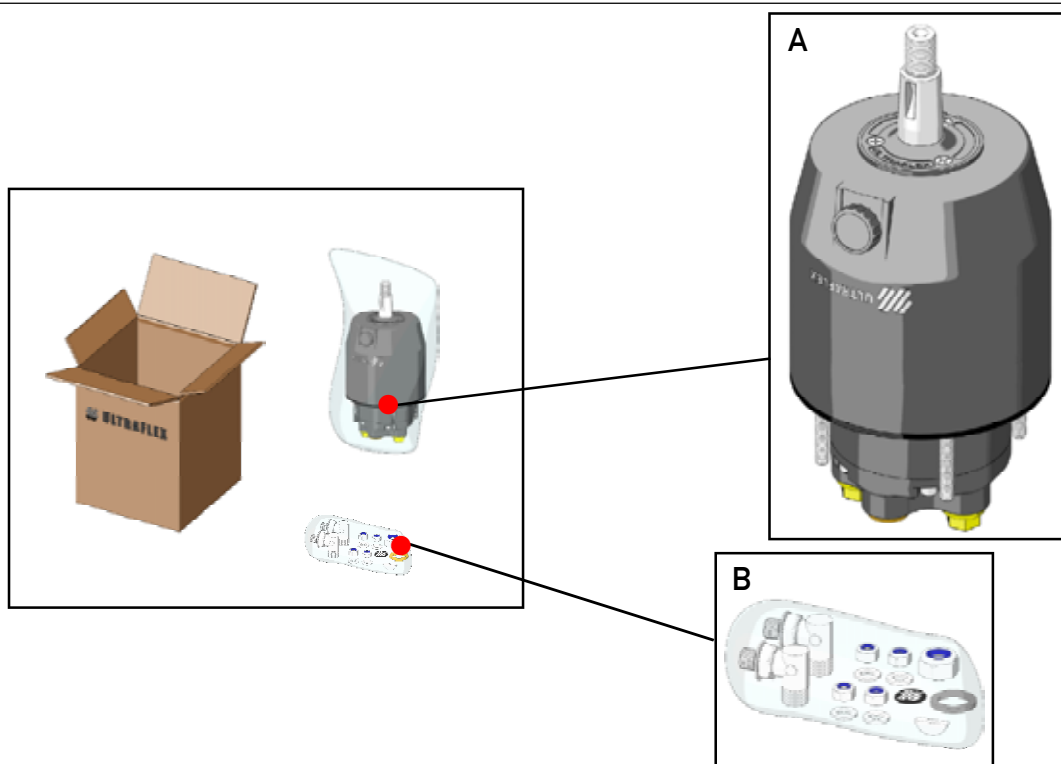

CONTENUTO DELL'IMBALLO STANDARD:

A) n°1 pompa UP25 F oppure UP28 F oppure UP33 F oppure UP39 F oppure UP45 F oppure UP25NV F oppure UP33NV F complete di guarnizione per fissaggio al cruscotto.

B) n°2 raccordi a 90° orientabili per il collegamento dei tubi Kit OB (forniti a parte);
 n°4 dadi per fissaggio al cruscotto;
 n°4 rondelle per fissaggio al cruscotto;
 n°1 dado per serraggio volante;
 n°1 rondella per serraggio volante;
 n°1 chiavetta per serraggio volante
 n°1 etichetta per tappo.



UP28 R - UP33 R - UP39 R - UP39-I R - UP45 R - UP45-I R

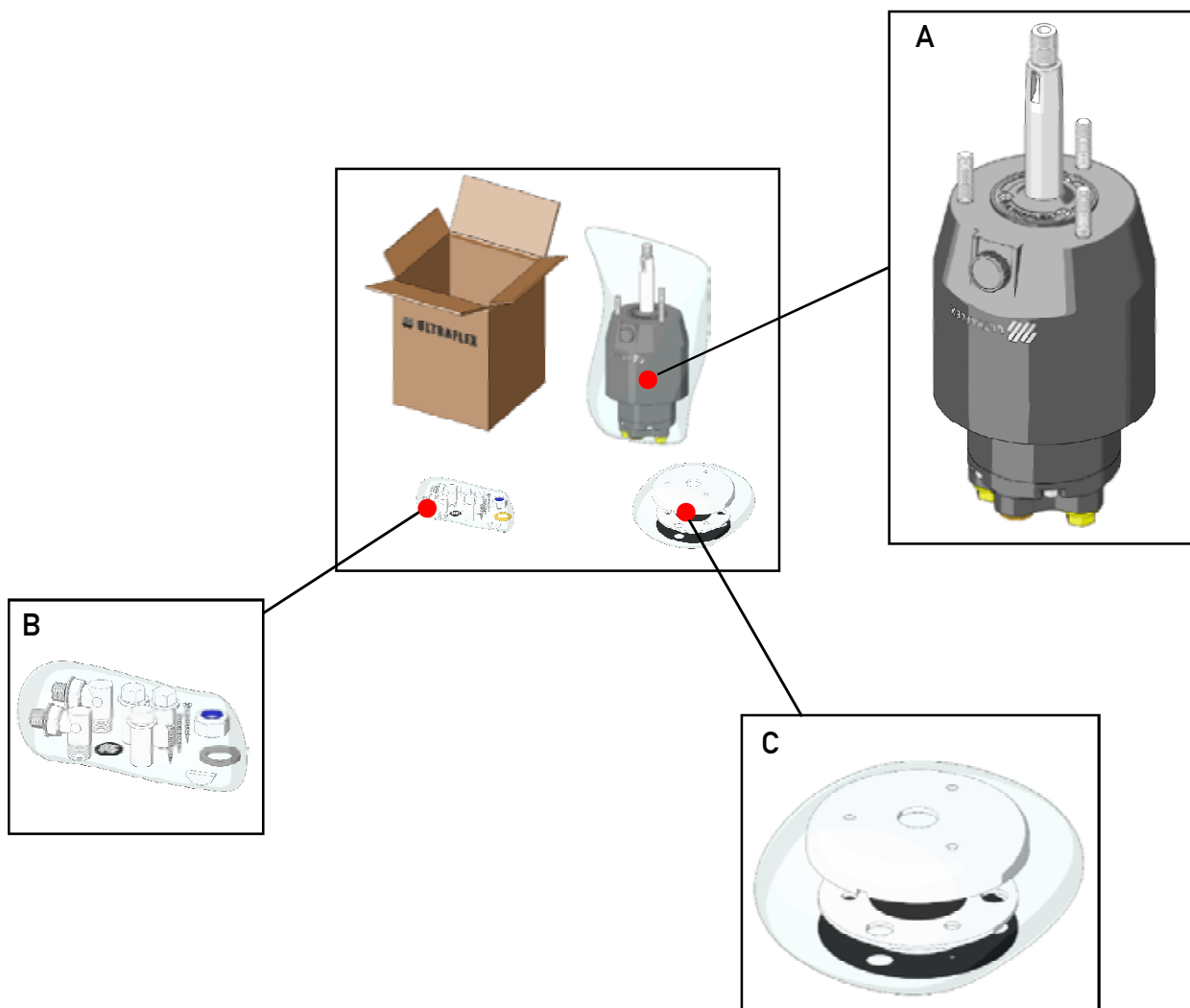

CONTENUTO DELL'IMBALLO STANDARD:

A) n°1 pompa UP28 R oppure UP33 R oppure UP39 R oppure UP39-I R oppure UP45 R oppure UP45-I R.

B) n°2 raccordi a 90° orientabili (ad esclusione delle pompe UP39-I R e UP 45-I R) per il collegamento dei tubi Kit OB (forniti a parte);

- n°3 viti speciali per fissaggio al cruscotto;
- n°3 viti autofilettanti per fissaggio coprimozzo;
- n°1 dado per serraggio volante;
- n°1 rondella per serraggio volante;
- n°1 chiavetta per serraggio volante
- n°1 etichetta per tappo.

C) n°1 guarnizione;
n°1 flangia;
n°1 coprimozzo.

NOTA

Le versioni UP39-I R e UP45-I R vengono fornite con raccordo speciale 1/4 NPT dritto per tubo metallico Ø 12 mm.

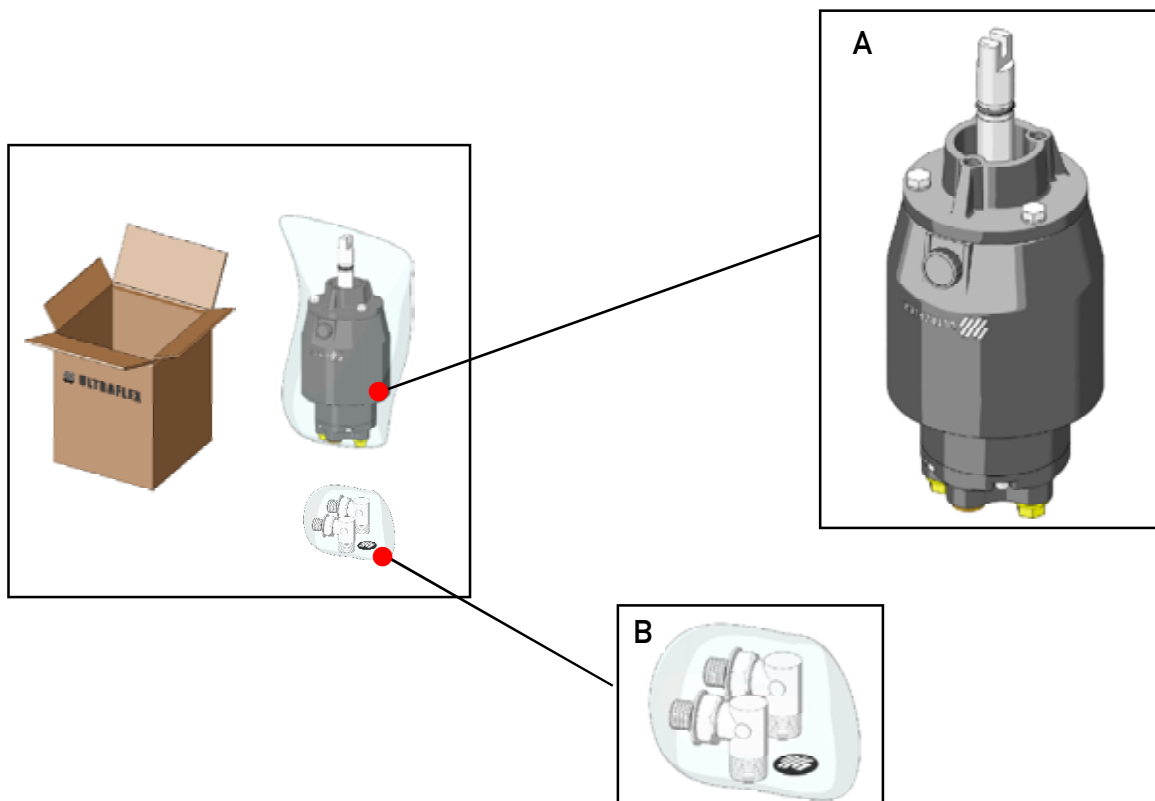

UP25 T - UP28 T - UP33 T - UP39 T - UP45 T**CONTENUTO DELL'IMBALLO STANDARD:**

A) n°1 pompa UP25 T oppure UP28 T oppure UP33 T oppure UP39 T oppure UP45 T.

B) n°2 raccordi a 90° orientabili per il collegamento dei tubi Kit OB (forniti a parte);
n°1 etichetta per tappo.

⚠ ATTENZIONE

L'imballo deve essere smaltito secondo le direttive vigenti.



3 INSTALLAZIONE

3.1 Utensili necessari per installazione pompe UP25 F - UP28 F - UP33 F - UP39 F - UP45 F - UP25NV F - UP33NV F



3.2 Installazione pompe UP25 F - UP28 F - UP33 F - UP39 F - UP45 F - UP25NV F - UP33NV F

1 Scegliere una posizione adatta per l'installazione della stazione di guida. Accertarsi che lo spazio sia sufficiente per manovrare il volante e che vi sia spazio per la pompa e per i suoi tubi e raccordi.

⚠ AVVERTENZA

Per un corretto fissaggio della pompa, lo spessore massimo del cruscotto deve essere 30 mm [1.18 in.]. Spessori diversi potrebbero compromettere la sicurezza di guida. Accertarsi che l'anello frenante dei 4 dadi autofrenanti in dotazione sia impegnato dal filetto dei grani.

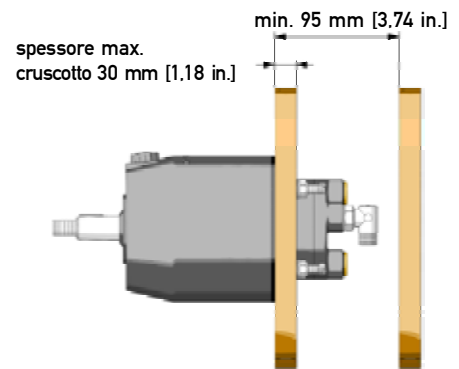

2 Rimuovere i tappi (1) dalla pompa (2) utilizzando un cacciavite.

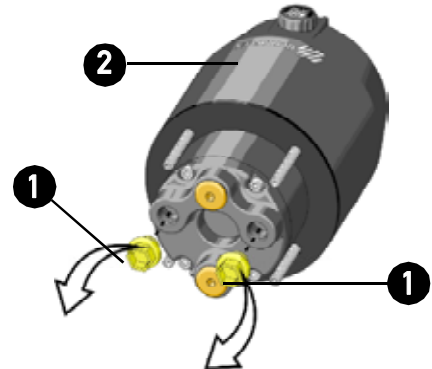

3 Avvitare completamente i dadi sui relativi raccordi a 90° (3), imboccare ed avvitare i raccordi a mano come indicato in figura fino al loro completo inserimento, orientarli fino a posizzarli nel modo più appropriato al collegamento dei tubi svitandoli al massimo di un giro, dopodichè serrare i dadi con una chiave esagonale da 11/16" con una coppia di 17.6 Nm (13 lb ft) fino a portare la rondella in battuta.

⚠ AVVERTENZA

NON UTILIZZARE nastro al teflon o qualunque altro tipo di nastro adesivo.
NON APPLICARE nessun tipo di sigilla raccordi come Loctite 542 o simile.

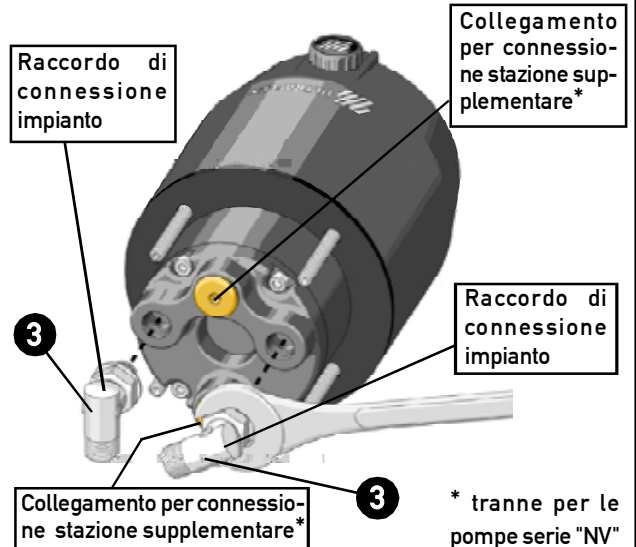

4 Utilizzando l'apposita dima allegata al presente manuale eseguire in posizione appropriata sul cruscotto i fori (4) necessari all'installazione.

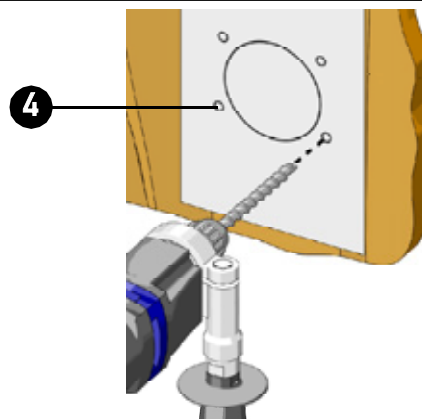

5 Posizionare la pompa (2) dalla parte frontale del cruscotto (5) infrapponendo la guarnizione (6) e fissarla inserendo le 4 rondelle (7) e serrando i 4 dadi autobloccanti (8) con una chiave da 10 mm con una coppia di 10 Nm (7,4 lb ft).

⚠ ATTENZIONE

Nel caso di smontaggio dei dadi autobloccanti (8), questi ultimi dovranno essere sostituiti. (Contattare il nostro servizio assistenza, vedi pag.40).

⚠ AVVERTENZA

Installare la pompa col foro di riempimento (9) posizionato in alto (come in figura) per un corretto funzionamento della pompa e per consentire di eseguire il completo riempimento e spurgo del sistema (vedi par. 3.11).

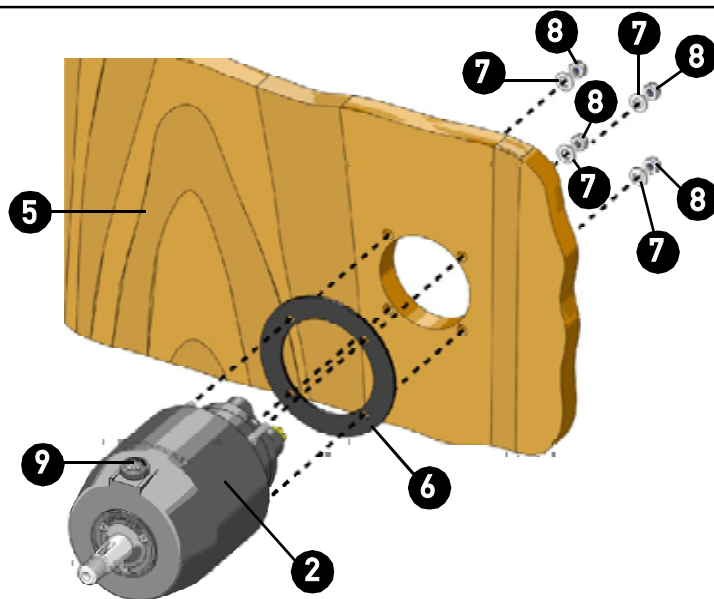

6 Calzare il volante fornito a parte (10) sull'albero pompa (11) utilizzando l'apposita chiavetta (12). Inserire la rondella (13) e con una chiave esagonale da 19 mm serrare il dado autobloccante (14) con una coppia di 40 Nm (29,5 lb ft) ingrassando la filettatura con un grasso antigrippaggio MOLYKOTE® 1000 o simili.

⚠ ATTENZIONE

Nel caso di smontaggio del dado autobloccante (14), quest'ultimo dovrà essere sostituito. (Contattare il nostro servizio assistenza, vedi pag.40).

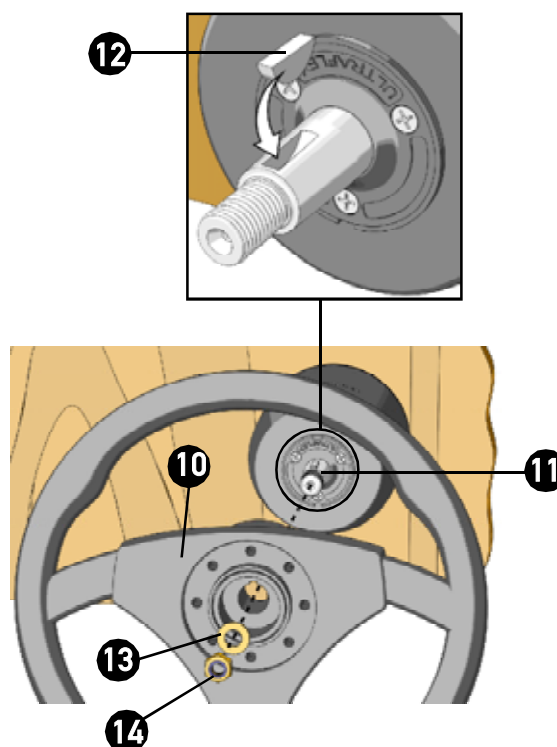

3.3 Utensili necessari per installazione pompe UP28 R-UP33 R-UP39 R-UP45 R



3.4 Installazione delle pompe UP28 R-UP33 R-UP39 R-UP45 R



1 Scegliere una posizione adatta per l'installazione della stazione di guida. Accertarsi che lo spazio sia sufficiente per manovrare il volante e che vi sia spazio per la pompa e per i suoi tubi e raccordi.

⚠ AVVERTENZA

Per un corretto fissaggio della pompa, lo spessore del cruscotto deve essere min. 25,4 mm [1 in.] e max. 38,1 mm [1,5 in.]. Spessori diversi potrebbero compromettere la sicurezza di guida.

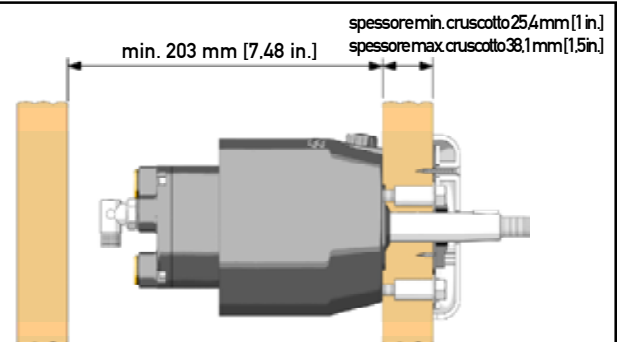

2 Rimuovere i tappi (1) dalla pompa (2) utilizzando un cacciavite.

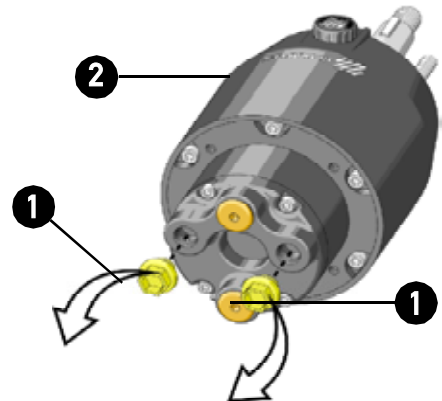

3 Avvitare completamente i dadi sui relativi raccordi a 90° (3), imboccare ed avvitare i raccordi a mano come indicato in figura fino al loro completo inserimento, orientarli fino a posizzarli nel modo più appropriato al collegamento dei tubi svitandoli al massimo di un giro, dopodichè serrare i dadi con una chiave esagonale da 11/16" con una coppia di 17,6 Nm (13 lb ft) fino a portare la rondella in battuta.

⚠ AVVERTENZA

NON UTILIZZARE nastro al teflon o qualunque altro tipo di nastro adesivo.
NON APPLICARE nessun tipo di sigilla raccordi come Loctite 542 o simile.

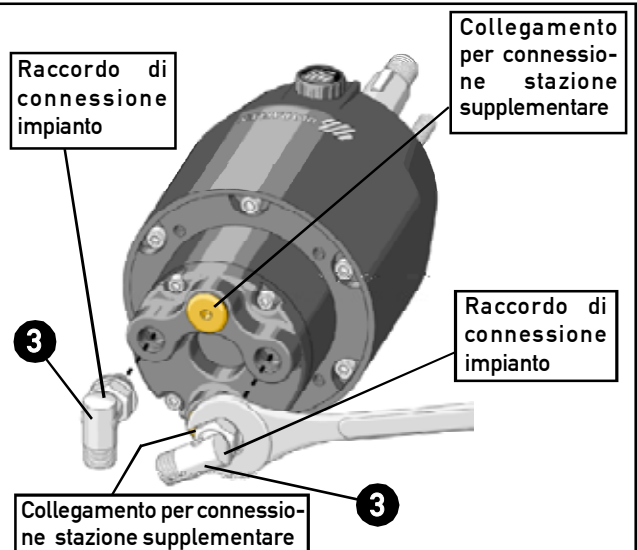

4 Utilizzando l'apposita dima allegata al presente manuale eseguire in posizione appropriata sul cruscotto i fori necessari all'installazione.

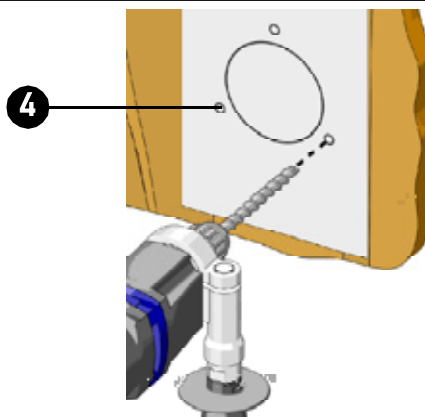

5 Posizionare la pompa (2) dalla parte posteriore del cruscotto (5). Posizionare quindi la guarnizione (6) come indicato in figura e la flangia (7) con il labbro di protezione verso l'esterno del cruscotto. Bloccare la pompa (2) con le 3 viti speciali (8) con una coppia di 25Nm (18.5 lb ft).

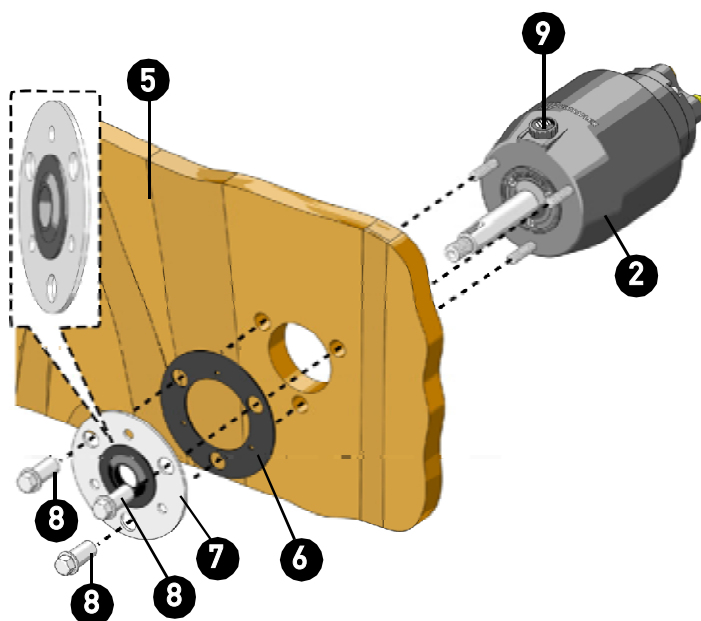

⚠ ATTENZIONE

Passare l'alberino della pompa attraverso la flangia munita di guarnizione facendo attenzione che la sede per la chiavetta non danneggi la guarnizione stessa.

⚠ AVVERTENZA

Installare la pompa col foro di riempimento (9) posizionato in alto (come in figura) per un corretto funzionamento della pompa e per consentire di eseguire il completo riempimento e spurgo del sistema (vedi par. 3.11).

6 Posizionare il coprimozzo (10) in plastica con lo scarico dell'acqua verso il basso e bloccarlo con le 3 viti autofilettanti (11) in dotazione con una coppia di 1.5Nm (1.13 lb ft).

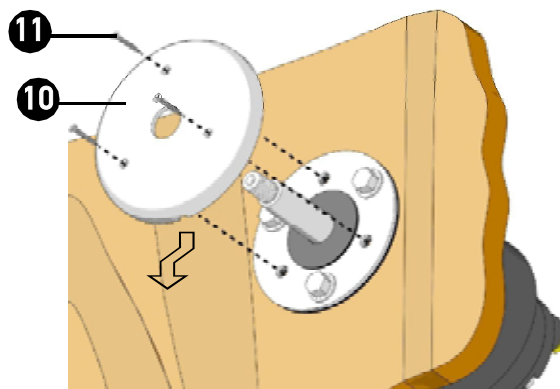

7 Calzare il volante fornito a parte (12) sull'albero pompa (13) utilizzando l'apposita chiavetta (14). Inserire la rondella (15) e con una chiave esagonale da 19 mm serrare il dado autobloccante (16) con una coppia di 40 Nm (29.5 lb ft) ingrassando la filettatura con un grasso antigrippaggio MOLYKOTE® 1000 o simili.

⚠ ATTENZIONE

Nel caso di smontaggio del dado autobloccante (16), quest'ultimo dovrà essere sostituito. (Contattare il nostro servizio assistenza, vedi pag.40).

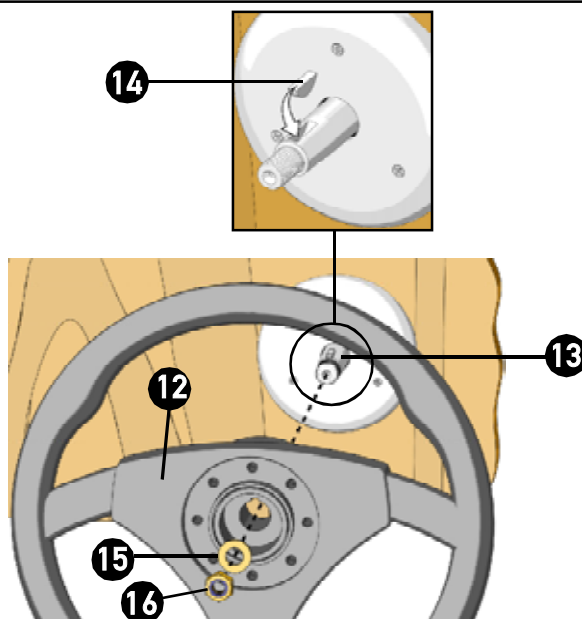

3.5 Utensili necessari per installazione pompe UP39-I R - UP45-IR



Loctite 542/545



MOLYKOTE® 1000

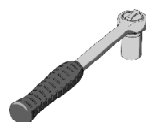

Chiave dinamometrica



Trapano



Cacciavite



Chiave esagonale 13 mm



Chiave esagonale 19 mm



Chiave esagonale 7/16"

3.6 Installazione delle pompe UP39-I R - UP45-I R



1 Scegliere una posizione adatta per l'installazione della stazione di guida. Accertarsi che lo spazio sia sufficiente per manovrare il volante e che vi sia spazio per la pompa e per i suoi tubi e raccordi.

⚠ AVVERTENZA

Per un corretto fissaggio della pompa, lo spessore del cruscotto deve essere min. 25,4 mm [1 in.] e max. 38,1 mm [1,5 in.]. Spessori diversi potrebbero compromettere la sicurezza di guida.

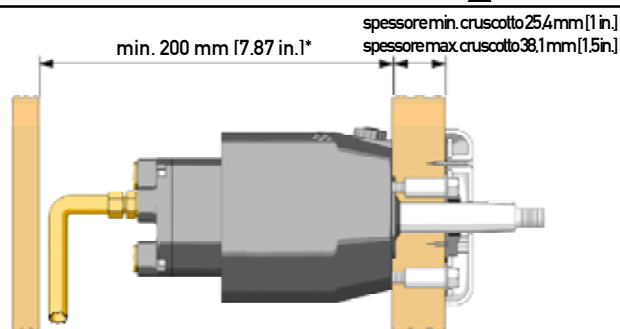

*Può variare in base alla posizione del tubo

2 Rimuovere i tappi (1) dalla pompa (2) utilizzando un cacciavite.

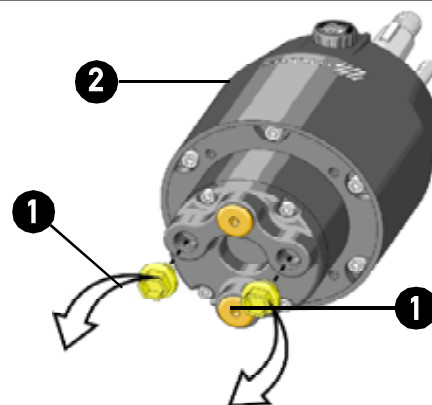

3 Applicare un sigilla raccordi tipo Loctite 542 o Loctite 545 sul filetto dei raccordi. Imboccare ed avvitare i raccordi conici (3) a mano fino al loro completo inserimento, dopodichè serrarli con una chiave esagonale da 7/16" con una coppia di serraggio di 17,6 Nm (13.0 lb ft).

⚠ AVVERTENZA

Non utilizzare nastro al teflon o qualunque altro tipo di nastro adesivo. Porre particolare attenzione al posizionamento del sigillante che, se introdotto nel sistema, porterebbe al suo bloccaggio e totale inutilizzo.

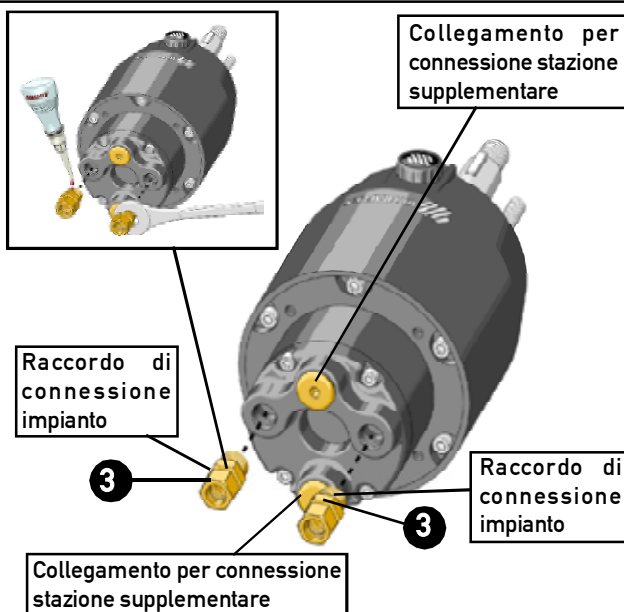

4 Utilizzando l'apposita dima allegata al presente manuale eseguire in posizione appropriata sul cruscotto i fori necessari all'installazione.

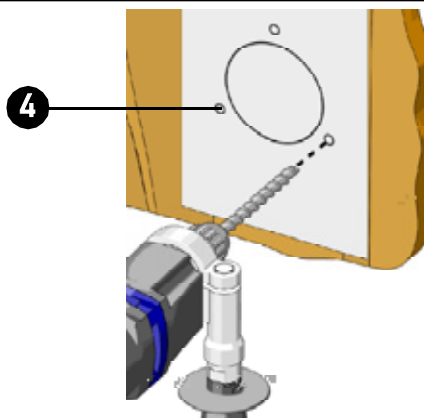

5 Posizionare la pompa (2) dalla parte posteriore del cruscotto (5). Posizionare quindi la guarnizione (6) come indicato in figura e la flangia (7) con il labbro di protezione verso l'esterno del cruscotto. Bloccare la pompa (2) con le 3 viti speciali (8) con una coppia di 25Nm (18,5 lb ft).

⚠ ATTENZIONE

Passare l'alberino della pompa attraverso la flangia munita di guarnizione facendo attenzione che la sede per la chiavetta non danneggi la guarnizione stessa.

⚠ AVVERTENZA

Installare la pompa col foro di riempimento (9) posizionato in alto (come in figura) per un corretto funzionamento della pompa e per consentire di eseguire il completo riempimento e spurgo del sistema (vedi par. 3.11).

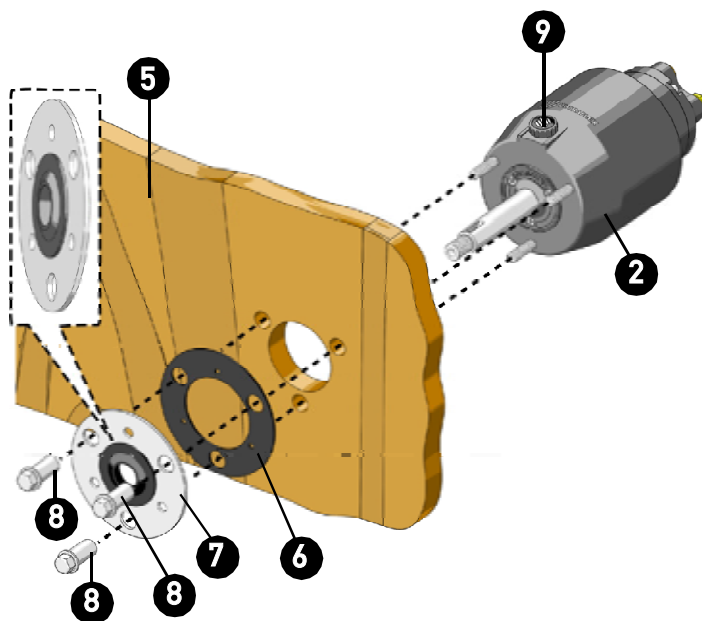

6 Posizionare il coprimozzo (10) in plastica con lo scarico dell'acqua verso il basso e bloccarlo con le 3 viti autofilettanti (11) in dotazione.

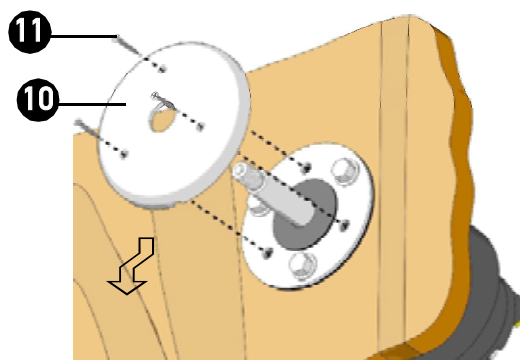

7 Calzare il volante fornito a parte (12) sull'albero pompa (13) utilizzando l'apposita chiavetta (14). Inserire la rondella (15) e con una chiave esagonale da 19 mm serrare il dado autobloccante (16) con una coppia di 40 Nm (29.5 lb ft) ingrassando la filettatura con un grasso antigrippaggio MOLYKOTE® 1000 o simili.

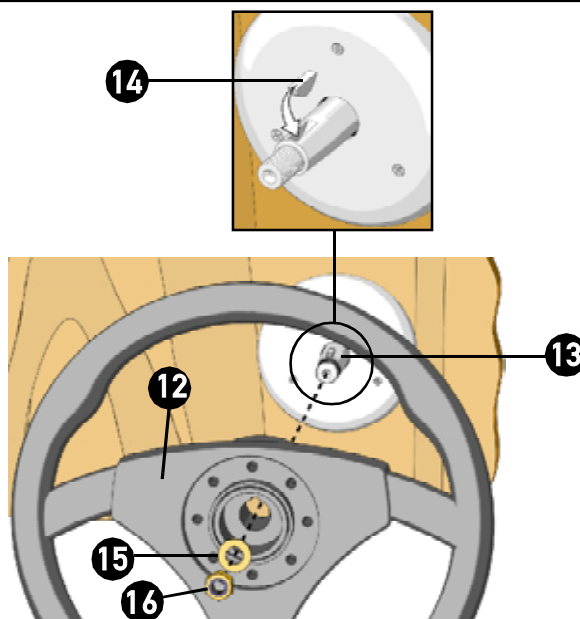

⚠ ATTENZIONE

Nel caso di smontaggio del dado autobloccante (16), quest'ultimo dovrà essere sostituito. (Contattare il nostro servizio assistenza, vedi pag.40).

3.7 Utensili necessari per installazione pompe UP25 T - UP28 T - UP33 T - UP39 T - UP45 T



Chiave esagonale 19/16"

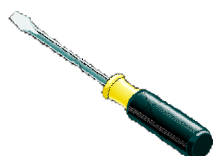

Cacciavite

* Gli utensili per montare il tilt X52 sono indicati sul manuale allegato al tilt X52.

3.8 Installazione delle pompe UP25 T - UP28 T - UP33 T - UP39 T - UP45 T



⚠ ATTENZIONE

Il meccanismo tilt X52 è fornito a parte.

1 Scegliere una posizione adatta per l'installazione della stazione di guida. Accertarsi che lo spazio sia sufficiente per manovrare il volante e che vi sia spazio per la pompa e per i suoi tubi e raccordi.

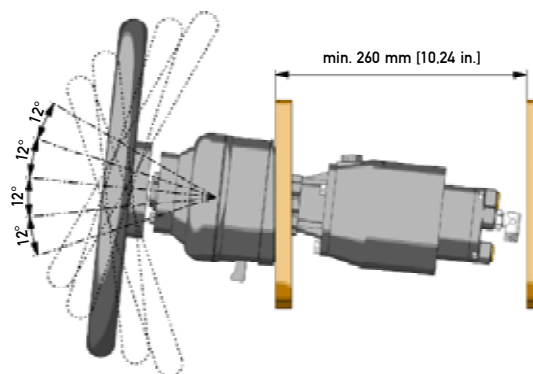

- 2** Rimuovere i tappi (1) dalla pompa (2) utilizzando un cacciavite.

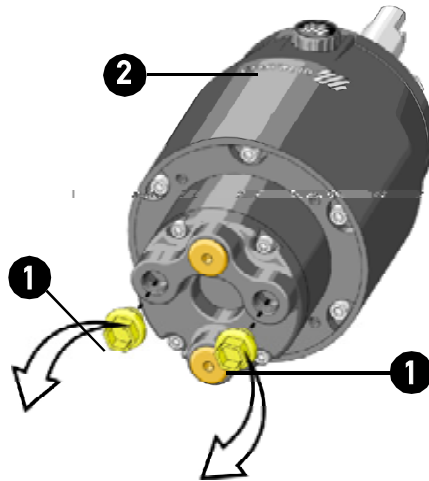

- 3** Fissare la staffa (3) in dotazione al tilt X52 al cruscotto (4) seguendo le istruzioni allegate al meccanismo tilt X52.

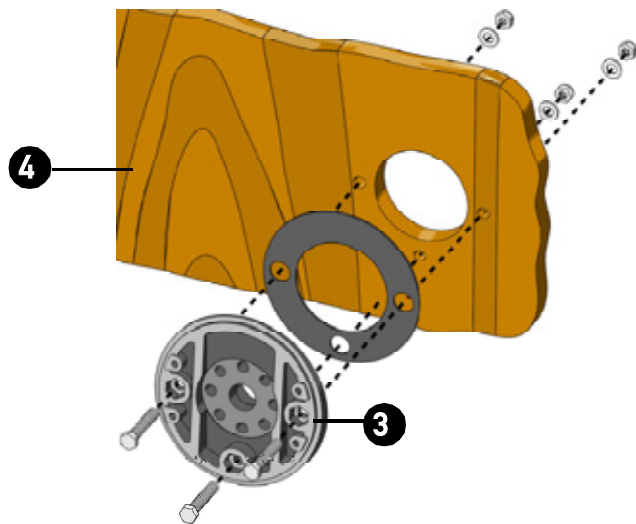

- 4** Avvitare completamente i dadi sui relativi raccordi a 90° (3), imboccare ed avvitare i raccordi a mano come indicato in figura fino al loro completo inserimento, orientarli fino a posizzarli nel modo più appropriato al collegamento dei tubi svitandoli al massimo di un giro, dopodichè serrare i dadi con una chiave esagonale da 11/16" con una coppia di 17,6 Nm (13 lb ft) fino a portare la rondella in battuta.

⚠ AVVERTENZA

NON UTILIZZARE nastro al teflon o qualunque altro tipo di nastro adesivo.
NON APPLICARE nessun tipo di sigilla raccordi come Loctite 542 o simile.

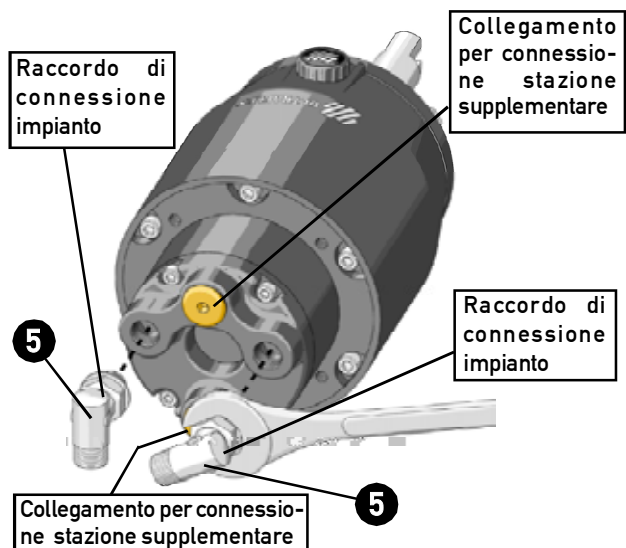

5 Fissare la pompa alla staffa (3) in dotazione al tilt X52 utilizzando le 3 viti M8 (6) in dotazione al tilt X52 seguendo le istruzioni allegate al meccanismo tilt X52.

⚠ AVVERTENZA

Installare la pompa col tappo di riempimento (7) posizionato in alto (come in figura) per un corretto funzionamento della pompa e per consentire di eseguire il completo riempimento e spurgo del sistema (vedi par. 3.11).

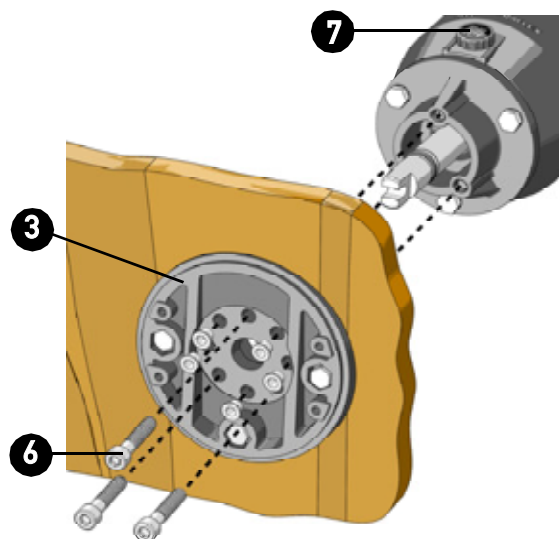

6 Allineare ed innestare il giunto cardanico del tilt all'albero della pompa, allentando di circa 1-1,5 giri le viti (8) sul giunto cardanico stesso e sempre seguendo la procedura descritta sul manuale di installazione in dotazione al meccanismo tilt X52. Riavvitare e serrare le viti (8) e fissare il tilt.

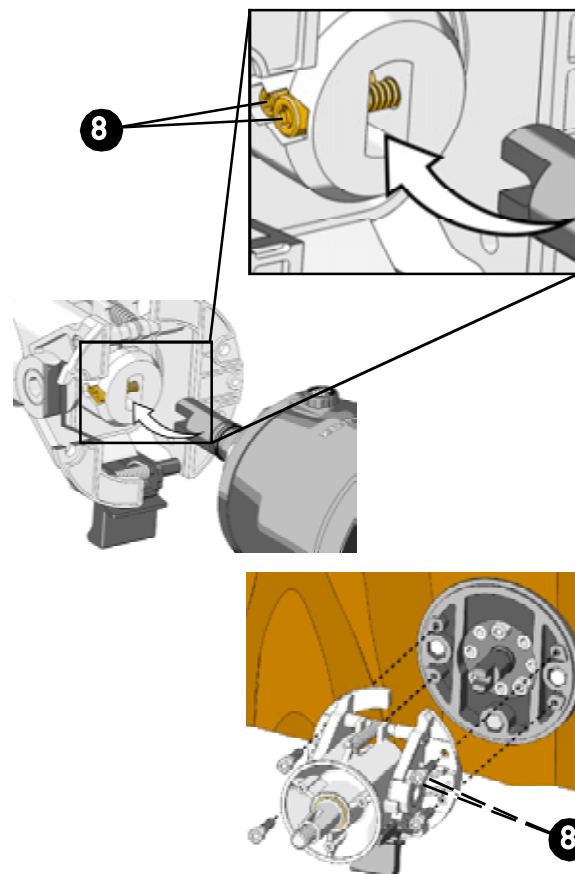

NOTA

Sulle pompe UP28 R-UP33 R-UP39 R -UP39-I R-UP45 R-UP45-I R e UP25 T-UP28 T-UP33 T-UP39 T-UP45 T per facilitare le operazioni di riempimento e spurgo del sistema idraulico, è possibile utilizzare il kit F **ULTRAFLEX** fornito separatamente (vedere relative istruzioni).



3.9 Tipi di installazione



Le pompe modello UP25-UP28-UP33-UP39-UP45 possono essere installate in un sistema di guida singolo o doppio (escluse le pompe serie "NV") e utilizzate in accoppiamento a diversi tipi di configurazioni di cilindri a montaggio frontale, laterale o entrobordo. Le pompe serie "NV" non possono essere utilizzate con cilindri di tipo sbilanciato.

⚠ ATTENZIONE

Eseguire sempre con attenzione l'esatto collegamento dei tubi come indicato nei manuali di installazione e manutenzione dei relativi cilindri idraulici.

MODELLI UP 25 F-R-T, UP 28 F-R-T, UP 33 F-R-T, UP 39 F-R-T, UP 45 F-R-T

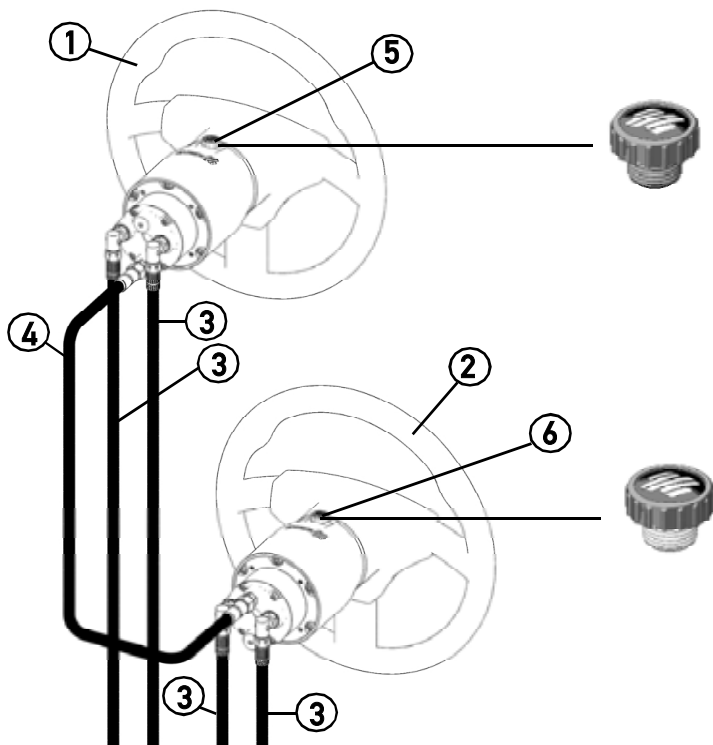

1. stazione di guida primaria
2. stazione di guida supplementare (non utilizzabile con pompe serie "NV")
3. kit OB
4. tubo da 3/8" compreso nel kit OB-2S
5. tappo di sfiato (tappo nero)
6. tappo senza sfiato (tappo grigio)

NOTA

Il Kit OB-2S viene fornito separatamente per applicazioni con doppia stazione.

MODELLI UP39-I R e UP-45 I R

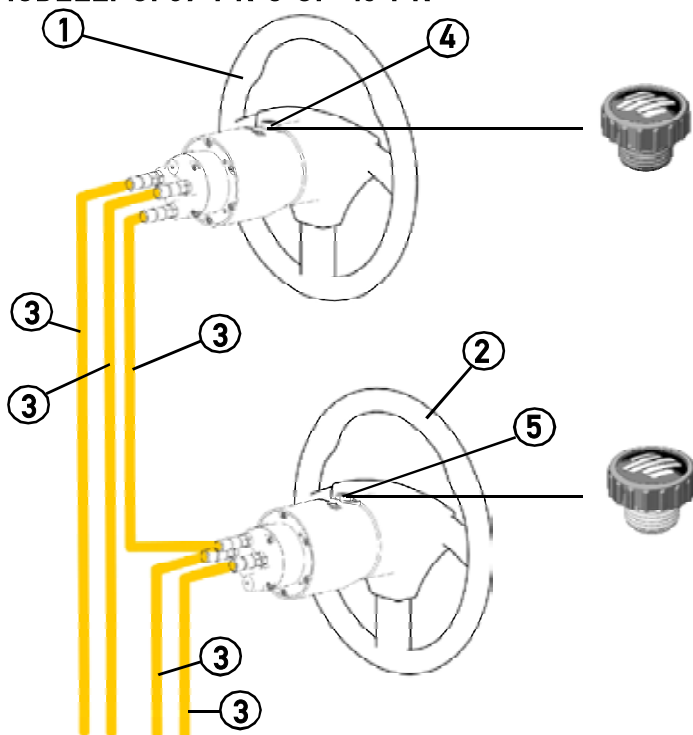

1. stazione di guida primaria
2. stazione di guida supplementare (non utilizzabile con pompe serie "NV")
3. tubo rigido metallico
4. tappo di sfiato (tappo nero)
5. tappo senza sfiato (tappo grigio)

NOTA

Il Kit OB 120 U-2S viene fornito separatamente per applicazioni con doppia stazione.



3.10 Collegamento dei tubi all'impianto

3.10.1 Collegamento dei tubi all'impianto modelli UP 25 F-R-T, UP 28 F-R-T, UP 33 F-R-T, UP 39 F-R-T, UP 45 F-R-T



- 1 Connettere i tubi idraulici **ULTRAFLEX** kit OB (forniti a parte) di collegamento tra la pompa e il cilindro seguendo le istruzioni riportate sul manuale di installazione del kit OB.
- 2 In caso di installazione di una o più stazioni di guida supplementari (escluse pompe serie "NV") occorre utilizzare il kit OB-2S seguendo le apposite istruzioni.

Posizionare sulle pompe i raccordi dritti da 3/8" (1) come indicato in figura.

Applicare un sigilla raccordi tipo Loctite 542 o Loctite 545 sul filetto dei raccordi. Imboccare ed avvitare i raccordi (1) a mano fino al loro completo inserimento, dopodichè serrarli con una chiave esagonale da 7/16" con una coppia di serraggio di 17,6 Nm (13.0 lb ft).

⚠ AVVERTENZA

Non utilizzare nastro al teflon o qualunque altro tipo di nastro adesivo. Porre particolare attenzione al posizionamento del sigillante che, se introdotto nel sistema, porterebbe al suo bloccaggio e totale inutilizzo.

STAZIONE DI GUIDA PRIMARIA

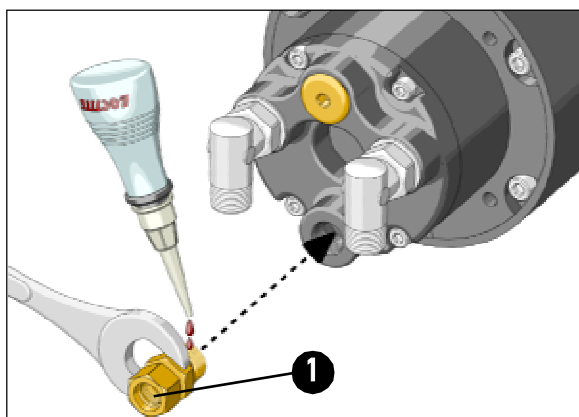

STAZIONE DI GUIDA SUPPLEMENTARE

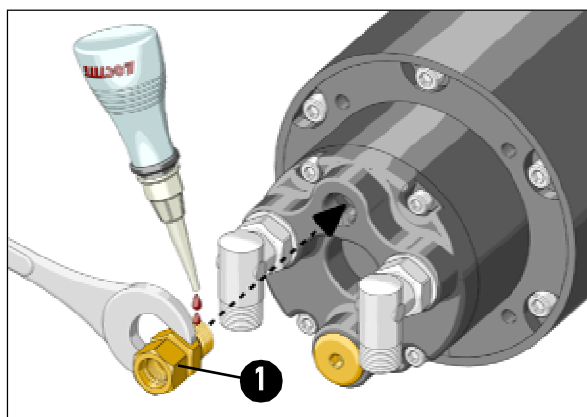

- 3 Collegare i tubi come indicato in figura seguendo le istruzioni riportate sui relativi manuali.

STAZIONE DI GUIDA PRIMARIA

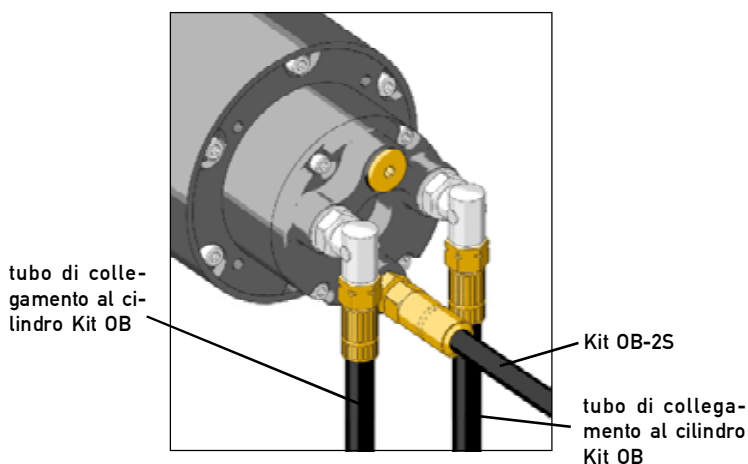

STAZIONE DI GUIDA SUPPLEMENTARE

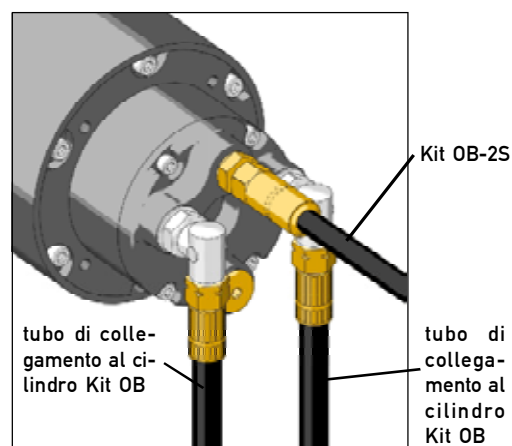

⚠️ AVVERTENZA

Porre particolare cura nel montare i tubi lontano da fonti di calore e da sostanze chimiche. Proteggere i tubi che devono essere fatti passare attraverso paratie usando passa paratie adeguati. Le curve devono essere perfettamente lisce; un tubo piegato o un'ammaccatura impedirebbero il libero passaggio dell'olio idraulico.

⚠️ AVVERTENZA

Mantenere la massima pulizia. Assicurarsi che i locali di lavoro siano privi di polvere e sporcizia. I tappi protettivi dei fori filettati, vanno tolti solo prima del collegamento dei raccordi e dei tubi. Accertarsi che i tubi siano puliti e privi di sbavature. In caso di utilizzo di tubi di rame o acciaio, il flussaggio è obbligatorio. L'utilizzo di tubi diversi dal Kit OB è sotto la piena responsabilità dell'installatore.

⚠️ AVVERTENZA

Al termine dell'installazione verificare che i tubi non interferiscano con il motore e con parti fisse o mobili dell'imbarcazione o del sistema di guida stesso.

⚠️ AVVERTENZA

Il raggio minimo di curvatura dei tubi è di 250 mm. Una curvatura eccessiva del tubo potrebbe causarne la rottura interna compromettendo il buon funzionamento del sistema. In tal caso occorre sostituire il tubo danneggiato.

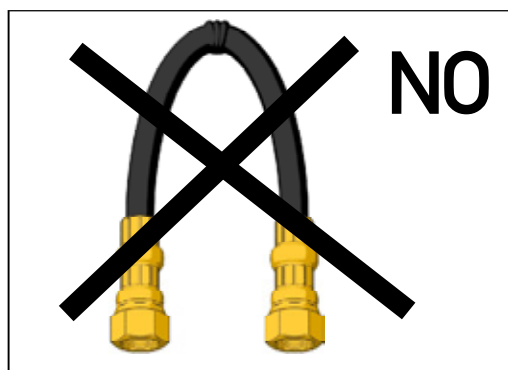
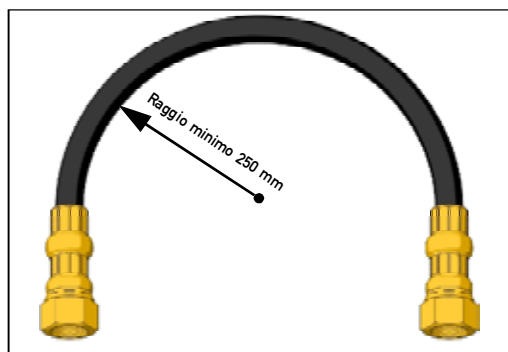

3.10.2 Scelta dei tubi rigidi per modelli UP39-I R e UP 45-I R



| MATERIALE TUBO ACCIAIO | SPECIFICHE | STRUTTURA | CONDIZIONI | TOLLERANZA DIAM. EST./SPESSORE PARETE | SUPERFICIE |
|-----------------------------|--------------------|------------------------------------|------------------------|---------------------------------------|--|
| St. 37.4 (=St 35.4, 1.0255) | DIN 2391/ DIN 1630 | Trafilato a freddo senza saldatura | NBK, DIN 2391-2 | DIN 2391-1-C | Fosfata, lubrificata o in A3C (placcata in zinco e cromata giallo) |
| E 235 (= 1.0308) | EN 10305-4 | | +N (=normale ricotto) | EN 10305-4 | |
| R37 | ISO 3304 | | NBK (=normale ricotto) | ISO 3304 | |
| St 52.4 (= 1.0580) | DIN 2391 | | NBK, DIN 2391-2 | DIN 2391-1 | |
| E355 (= 1.0580) | EN 10305-4 | | +N (=normale ricotto) | EN 10305-4 | |
| R50 | ISO 3304 | | NBK (=normale ricotto) | ISO 3304 | |

| MATERIALE TUBO ACCIAIO INOSSIDABILE | SPECIFICHE | STRUTTURA | CONDIZIONI | TOLLERANZA DIAM. EST./SPESSORE PARETE | SUPERFICIE |
|-------------------------------------|-------------------------|------------------------------------|---|--|------------|
| 1.4571 (= TP 316 Ti) | DIN 2391 | Trafilato a freddo senza saldatura | Ricotto completamente | DIN 2391-1 | Liscia |
| 1.4541 (= TP 321) | | | DIN 17458 | | |
| 1.4404 (= TP 316L) | EN ISO 1127 o Astm A269 | | Ricotto completamente | D4/T3 (EN ISO 1127) | |
| 1.4301 (= TP 304) | | | | | |
| 1.4401 (= TP 316) | EN ISO 1127 | Tubo a saldare | DIN 17457-K2 per diam. Est. 6-12 mm, saldato trafilato a freddo (CDW) con superficie e esterna levigata per diam. Est. 14-42 mm | Liscia, con saldatura quasi invisibile | |
| 1.4301 (= TP 304) | | | | | |
| 1.4541 (= TP 321) | | | | | |

| MATERIALE TUBO RAME | SPECIFICHE | STRUTTURA | CONDIZIONI | TOLLERANZA DIAM. EST./SPESSORE PARETE | SUPERFICIE |
|---------------------|------------|----------------------|------------|---------------------------------------|--------------------------|
| R 290 | EN 1057 | Tubo senza saldatura | EN 1057 | EN 1057 | Pulita, levigata, liscia |



NOTA

La presente tabella viene riportata solo a scopo indicativo.

ULTRAFLEX non si assume la responsabilità circa la scelta del tubo, che dev'essere fatta a cura dell'installatore in base alla pressione di utilizzo.

AVVERTENZA

La valvola di protezione da sovrappressioni delle pompe UP Series **ULTRAFLEX** protegge l'impianto da pressioni maggiori di 70 bar (1000 PSI) circa.

I riferimenti normativi sono aggiornati alla data di pubblicazione del presente documento, resta a carico dell'installatore verificare la presenza di eventuali aggiornamenti.

3.10.3 Collegamento dei tubi all'impianto modelli UP39-I R e UP 45-I R



- 1 Connettere i tubi rigidi (diametro esterno 12mm) di collegamento tra la pompa e il cilindro.
- 2 In caso di installazione di una o più stazioni di guida supplementari (escluse pompe serie "NV") occorre utilizzare il kit OB 120 U-2S seguendo le apposite istruzioni.

Posizionare sulle pompe i raccordi dritti (1) per tubo da 12mm come indicato in figura. Applicare un sigilla raccordi tipo Loctite 542 o Loctite 545 sul filetto dei raccordi. Imboccare ed avvitare i raccordi (1) a mano fino al loro completo inserimento, dopodichè serrarli con una chiave esagonale da 7/16" con una coppia di serraggio di 17,6 Nm (13.0 lb ft).

AVVERTENZA

Non utilizzare nastro al teflon o qualunque altro tipo di nastro adesivo. Porre particolare attenzione al posizionamento del sigillante che, se introdotto nel sistema, porterebbe al suo bloccaggio e totale inutilizzo.

STAZIONE DI GUIDA PRIMARIA

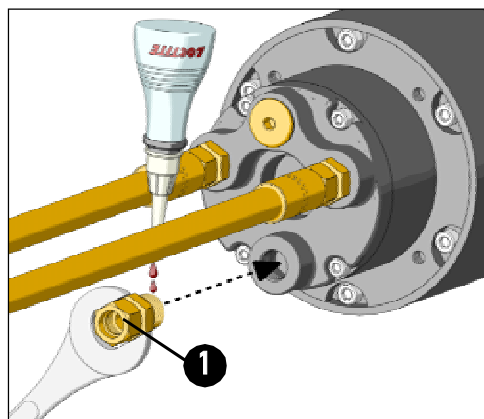

STAZIONE DI GUIDA SUPPLEMENTARE

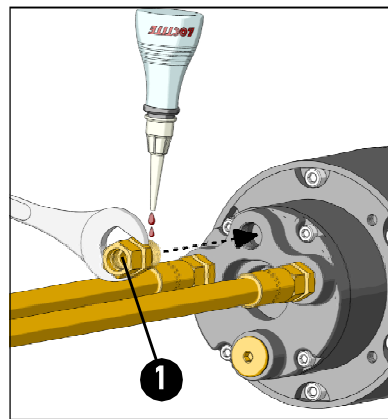

- 3 Collegare i tubi come indicato in figura e serrare con una coppia appropriata secondo le specifiche del costruttore del tubo.

STAZIONE DI GUIDA PRIMARIA

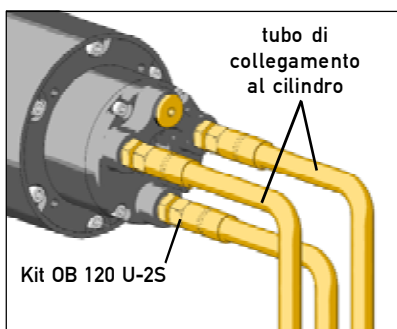

STAZIONE DI GUIDA SUPPLEMENTARE

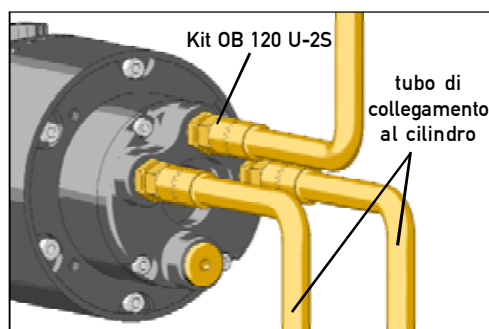

NOTA

Il Kit OB 120 U-2S viene fornito separatamente per applicazioni con doppia stazione e comprende tutti i raccordi necessari per il tubo di rame da 12mm.

Quest'ultimo deve essere acquistato separatamente.

⚠ PERICOLO

I raccordi montati sulla pompa NON sono orientabili. Il loro eventuale svitamento ne comporta la conseguente rottura rendendo la pompa inutilizzabile.

NOTA

Il montaggio della tubazione rigida (taglio, curvatura e passaggio paratia) dovrà essere effettuato da personale specializzato attenendosi alle indicazioni del costruttore. In caso di tubazioni di rame o acciaio il flussaggio è obbligatorio.

3.11 Riempimento e spurgo

Dopo la prima installazione e a seguito di eventuali interventi di manutenzione occorre eseguire l'operazione di riempimento del sistema con olio idraulico. Questa operazione ha lo scopo di eliminare completamente l'aria dall'impianto garantendo il buon funzionamento del sistema. Il sistema idraulico deve essere riempito dal punto più alto del sistema stesso, ossia a livello della stazione di comando superiore.

⚠ ATTENZIONE

Per evitare che si formino bolle d'aria nell'olio, è necessario riempire lentamente il serbatoio.

⚠ AVVERTENZA

Le operazioni di riempimento e spurgo devono essere effettuate almeno da due operatori.

NOTA

Le operazioni di riempimento e spurgo possono essere facilitate tramite l'utilizzo dell'attrezzatura di spurgo automatico BUBBLE BLUSTER® (fornito a parte).

⚠ PERICOLO

Usare olio **ULTRAFLEX** o olii compatibili.

L'olio idraulico OL150 è specificatamente formulato per **ULTRAFLEX** allo scopo di mantenere più a lungo nel tempo l'alto livello qualitativo e di performance dei prodotti **ULTRAFLEX**.

La sua particolare formula "Zinco Free" favorisce la protezione dall'ossidazione marina.

La particolare miscela di componenti antiusura e stabilizzanti, di cui OL150 è composto, consentono di ottenere un ottimo risultato in termini di vita del prodotto e costanza di prestazione nelle diverse condizioni ambientali.

L'olio idraulico **ULTRAFLEX** risponde alla normativa ISO 10592 relativa ai sistemi di guida idraulici.

ULTRAFLEX non è responsabile di eventuali danni o cali prestazionali dovuti all'utilizzo di oli idraulici diversi da OL150.

⚠ PERICOLO

NON utilizzate in nessun caso oli da trasmissione tipo ATF Dexron II o oli per freni che potrebbero provocare il bloccaggio del sistema di guida.

Oli compatibili con OL150 **ULTRAFLEX** sono:

- Shell Tellus T15 e Shell Tellus T22
- Mobil DTE 11M

NOTA

ULTRAFLEX non potrà garantire la compatibilità degli oli citati con OL150 in caso di variazione alle formulazioni da parte dei produttori degli oli stessi, in particolare non potrà garantirne la rispondenza alla ISO 10592 relativa ai sistemi di guida idraulici. Eventuali cali prestazionali e/o di durata non saranno in nessun caso imputabili ad **ULTRAFLEX**.



Nei giorni immediatamente successivi al riempimento, è necessario tenere sotto controllo il livello dell'olio; se necessario, rabboccare il sistema. Inizialmente il livello dell'olio può calare, in quanto possono liberarsi piccole quantità di aria omogeneamente distribuite. In funzione dei diversi tipi di installazione, occorre eseguire le diverse procedure di spurgo, come illustrato nella pagina seguente.

3.11.1 Posizionamento della bottiglia dell'olio

Per effettuare questa operazione è necessario il kit di riempimento olio (1 spillo, 1 tubo trasparente, 1 raccordo portatubo e 1 beccuccio per bottiglia olio) NON fornito in dotazione.

- Rimuovere il tappo pompa e inserire il raccordo di riempimento.
 - Fissare un beccuccio ad una bottiglia nuova di olio idraulico, collegando il tubo flessibile dal raccordo di riempimento al beccuccio della bottiglia.
 - Capovolgere la bottiglia e forarla con lo spillo, come indicato in figura, in modo da facilitare il passaggio dell'olio verso la pompa.
- Riempire la pompa fino a quando non siano più visibili bolle d'aria nel tubo flessibile.

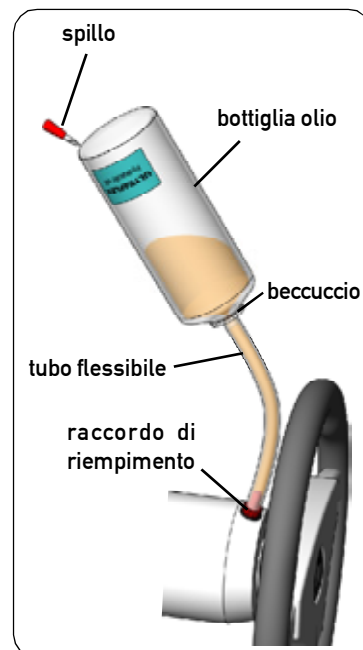

⚠ AVVERTENZA

Al momento della sostituzione delle bottiglie d'olio durante il processo di riempimento, chiudere tutte le valvole di spurgo del cilindro/i. Per spurgare l'impianto, verificare che nel tubo flessibile di riempimento sia sempre presente l'olio. Se durante il processo di spurgo dovesse penetrare aria all'interno del sistema, l'intero processo dovrà essere ripetuto dall'inizio.

⚠ ATTENZIONE

Sostituire la bottiglia prima che si svuoti e non riutilizzare l'olio fuoriuscito dal sistema se non dopo almeno 24 ore.

3.11.2 Procedura di spurgo

NOTA

Eseguire la procedura di spurgo come descritto nel manuale di installazione e manutenzione relativo al cilindro utilizzato, infine ottenere un idoneo livello dell'olio ruotando il volante di 1/2 giro e facendo uscire l'olio dalla valvola di spurgo. Chiudere la valvola e fare un check del sistema.

3.12 Raccomandazione generale

⚠ AVVERTENZA

E' molto importante verificare che l'aria sia stata completamente spurgata dall'impianto prima di utilizzare la barca! Si consiglia di tentare di spostare manualmente il/i motore/i o il/i timone/i a destra e a sinistra, prestando attenzione a qualsiasi movimento dello stelo del cilindro.

Un eccessivo movimento relativo tra corpo e stelo del cilindro è sintomatico della presenza di aria da spurgare. La presenza di aria nell'impianto può dar luogo a risposte non corrette ai comandi, con conseguente rischio di danni, lesione o morte.

⚠ AVVERTENZA

Verificare muovendo la pompa che il sistema risponda prontamente.

⚠ PERICOLO

Dopo 24 ore ripetere la procedura di spurgo e verificare che non ci siano perdite.



4 AVVERTENZE DI SICUREZZA

Questa sezione ha lo scopo di illustrare le norme di sicurezza da seguire per un uso corretto dell'apparecchiatura. Si raccomanda di leggere con molta attenzione questa sezione. Si raccomanda di leggere i manuali forniti con gli altri componenti del sistema di guida.

4.1 Norme di sicurezza durante l'installazione e l'uso

RISPETTATE TASSATIVAMENTE le precauzioni ed i criteri di sicurezza indicati qui di seguito.

ULTRAFLEX declina ogni responsabilità nel caso in cui l'utilizzatore non li osservi, così come non è responsabile per qualsiasi tipo di negligenza che venga commessa durante l'utilizzo del sistema.

PERICOLO

- **NON INSERIRE LE MANI TRA ORGANI IN MOVIMENTO.**
- Non disattivare o rendere in qualsiasi modo non operativi i dispositivi di sicurezza.
- Non modificare o aggiungere dispositivi all'impianto, senza autorizzazione scritta o previo intervento tecnico **ULTRAFLEX** che compri nella descrizione dell'intervento la modifica apportata.
- Non utilizzare l'apparecchiatura per uno scopo diverso da quello per cui è stata destinata, specificato nel manuale di installazione e manutenzione.
- Non far eseguire l'installazione a personale non specializzato.
- Non smontare le connessioni idrauliche senza prima aver effettuato lo scarico completo dell'olio nel sistema. Le tubazioni possono contenere olio ad alta pressione.
- In caso di installazione con doppia stazione non agire MAI contemporaneamente su entrambe le stazioni. Le due stazioni infatti sono sempre attive sulla timoneria. L'effetto della rotazione del volante su entrambe le stazioni andrà a sommarsi producendo una manovra indesiderata.

AVVERTENZA

- Non salire con i piedi sul cilindro.
- Dopo l'installazione e lo spurgo del sistema, procedere ad un controllo prima di iniziare la navigazione. Ruotare il volante fino a portare il cilindro o i cilindri installati a fondo corsa. Ripetere la manovra ruotando il volante nella direzione opposta. Ripetere l'operazione con tutte le timonerie presenti fino ad essere certi della corretta installazione e dell'ottimo funzionamento del sistema.
- Porre particolare cura nell'applicazione di materiale di tenuta liquido (tipo Loctite). In caso d'immissione nel sistema idraulico, questo causerebbe danni e rotture.
- Per sigillare i raccordi, non utilizzare in nessun caso nastro al teflon o qualunque tipo di nastro adesivo, che potrebbe essere aspirato dal sistema e danneggiare irreparabilmente lo stesso.
- In fase d'installazione del sistema, avere particolare cura nel mantenere la massima pulizia, per evitare che qualunque corpo estraneo possa penetrare nel sistema stesso. Anche il più piccolo oggetto potrebbe arrecare danni permanenti non immediatamente rilevabili.
- Evitare raggi di curvatura dei tubi troppo stretti.
- Evitare il contatto delle tubazioni con bordi o spigoli taglienti.
- Evitare il contatto dei tubi con fonti di calore.

4.2 Abbigliamento

AVVERTENZA

Durante le fasi di installazione, ispezione o manutenzione:

E' SEVERAMENTE PROIBITO indossare collane, braccialetti o indumenti che potrebbero impigliarsi in parti in movimento.

5 MANUTENZIONE

5.1 Manutenzione ordinaria

⚠ AVVERTENZA

La mancata osservanza dei controlli di manutenzione può causare la perdita di guida con possibili danni materiali e/o lesioni personali. I requisiti per la manutenzione variano secondo il clima, la frequenza ed il modo d'impiego. Sono necessarie ispezioni almeno annuali effettuate da un esperto meccanico nautico. Controllare i raccordi e lo stato delle guarnizioni del cilindro e della timoneria, per prevenire eventuali perdite; sostituirle se necessario. Per mantenere un idoneo livello dell'olio nel serbatoio procedere al riempimento ed allo spurgo del sistema come indicato nel manuale al paragrafo 3.11 e nelle procedure di spurgo dei cilindri **ULTRAFLEX**. Controllare l'usura dei tubi e dell'intero sistema, il fissaggio dei dadi e dei bulloni ogni sei mesi ed assicurarsi della loro perfetta integrità. Detergere il sistema utilizzando acqua e sapone non aggressivo e non abrasivo.

⚠ PERICOLO

Utilizzare esclusivamente olii idraulici compatibili, indicati nel paragrafo "caratteristiche tecniche" e "riempimento e spurgo". Non utilizzare in nessun caso olii per freni o fluido per trasmissioni automatiche (ATF).

⚠ ATTENZIONE

Nel caso di smontaggio dei dadi autobloccanti, questi ultimi dovranno essere sostituiti. (Contattare il nostro servizio assistenza, vedi pag.40).

5.2 Smontaggio volante

Per estrarre il volante dall'albero della pompa, utilizzare un apposito estrattore.

⚠ AVVERTENZA

Non utilizzare il martello o altri utensili che potrebbero danneggiare in maniera irreparabile la pompa.

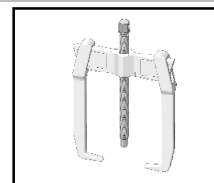

5.3 Ricerca guasti

⚠ AVVERTENZA

Ogni qualvolta i seguenti controlli richiedano la rimozione e/o smontaggio dei componenti del sistema di guida, richiedere l'intervento di personale qualificato. **ULTRAFLEX** offre le indicazioni generali e non può essere ritenuta responsabile per eventuali informazioni e conseguenze derivanti da un errato smontaggio.

| PROBLEMA | POSSIBILE CAUSA | INTERVENTO |
|---|---|--|
| Nella fase di riempimento, la timoneria risulta bloccata. | <ul style="list-style-type: none"> Bloccaggio nelle tubazioni tra la timoneria e il cilindro. | <ul style="list-style-type: none"> Sostituire le tubazioni. <p>⚠ PERICOLO Il tubo danneggiato deve essere sostituito. La mancata sostituzione può causare la perdita di guida provocando lesioni personali gravi o danni patrimoniali.</p> |
| Il sistema è difficile da riempire. L'aria gorgoglia nella parte alta del serbatoio della timoneria anche dopo aver riempito totalmente il sistema. | <ul style="list-style-type: none"> Aria nel sistema. | <ul style="list-style-type: none"> Ripetere la procedura di riempimento e spurgo del sistema. Installare i tubi in orizzontale e in ogni caso con inclinazione massima di circa 3cm per metro. |
| | <ul style="list-style-type: none"> Trafilamento del raccordo di spurgo del cilindro. | <ul style="list-style-type: none"> Chiudere bene il raccordo di spurgo sul cilindro. |
| | <ul style="list-style-type: none"> Tubo attorcigliato. | <ul style="list-style-type: none"> Svolgere e raddrizzare il tubo. |
| | <ul style="list-style-type: none"> Timoneria montata col foro di riempimento in posizione bassa. | <ul style="list-style-type: none"> Montare la timoneria col foro di riempimento in posizione alta. |



| | | |
|---|--|--|
| <p>La timoneria è rigida e difficilmente manovrabile, anche quando l'imbarcazione è ferma.</p> | <ul style="list-style-type: none"> • Restringimento nelle tubazioni o nei raccordi. | <ul style="list-style-type: none"> • Cercare il restringimento e rimuoverlo. |
| <p>La timoneria è rigida e difficilmente manovrabile, anche quando l'imbarcazione è ferma.</p> | <ul style="list-style-type: none"> • Aria nell'olio. | <ul style="list-style-type: none"> • Ripetere la procedura di riempimento e spurgo del sistema. |
| <p>La timoneria è rigida e difficilmente manovrabile, anche quando l'imbarcazione è ferma, se si utilizzano cilindri sbilanciati.</p> | <ul style="list-style-type: none"> • Utilizzo olio errato. | <ul style="list-style-type: none"> • Scaricare subito il sistema di riempimento e spurgo del sistema. <p>⚠ AVVERTENZA Eventuali danni causati dall'uso di fluidi diversi da quelli raccomandati in questo manuale, non sono in alcun modo imputabili a ULTRAFLEX e annullano automaticamente la garanzia.</p> |
| <p>La timoneria è rigida e difficilmente manovrabile, anche quando l'imbarcazione è ferma, se si utilizzano cilindri sbilanciati.</p> | <ul style="list-style-type: none"> • Introduzione nella valvola, di sporcizia o trucioli. | <p>⚠ AVVERTENZA Non utilizzare l'imbarcazione e richiedere l'intervento di un tecnico specializzato per la pulizia della valvola.</p> |
| <p>La timoneria si manovra agevolmente in banchina, ma diventa rigida quando l'imbarcazione è in movimento.</p> | <ul style="list-style-type: none"> • Il volante di guida è troppo piccolo. | <ul style="list-style-type: none"> • Sostituire il volante di guida con uno più grande. <p>⚠ AVVERTENZA Solo entro le dimensioni massime consentite dalla timoneria.</p> |
| <p>La timoneria si manovra agevolmente in banchina, ma diventa rigida quando l'imbarcazione è in movimento.</p> | <ul style="list-style-type: none"> • La regolazione del correttore di assetto è sbagliata. | <ul style="list-style-type: none"> • Regolare il correttore di assetto. |
| <p>La timoneria si manovra agevolmente in banchina, ma diventa rigida quando l'imbarcazione è in movimento.</p> | <ul style="list-style-type: none"> • Aria nell'olio. | <ul style="list-style-type: none"> • Controllare il livello dell'olio e ripetere la procedura di spurgo come indicato nel manuale. |
| <p>Ruotando il volante, lo stelo (cilindri a stelo mobile) o il corpo (cilindri a stelo fisso) del cilindro non si muovono.</p> | <ul style="list-style-type: none"> • Aria nel sistema. | <ul style="list-style-type: none"> • Ripetere la procedura di riempimento e spurgo del sistema. |
| <p>Ruotando il volante, lo stelo (cilindri a stelo mobile) o il corpo (cilindri a stelo fisso) del cilindro non si muovono.</p> | <ul style="list-style-type: none"> • Perdita d'olio. | <ul style="list-style-type: none"> • Cercare la perdita e rivolgersi a personale qualificato. |
| <p>Ruotando il volante, lo stelo (cilindri a stelo mobile) o il corpo (cilindri a stelo fisso) del cilindro non si muovono.</p> | <ul style="list-style-type: none"> • Timoneria montata col foro di riempimento in posizione bassa. | <ul style="list-style-type: none"> • Montare la timoneria col foro di riempimento in posizione alta. |
| <p>Perdite d'olio dai raccordi della timoneria.</p> | <ul style="list-style-type: none"> • Raccordi avvitati male o con coppia di serraggio insufficiente. | <ul style="list-style-type: none"> • Serrare i raccordi. Applicare una coppia massima di 20Nm (15 in.lbs). |
| <p>Perdite d'olio dai raccordi della timoneria.</p> | <ul style="list-style-type: none"> • Mancanza di fluido sigilla raccordi. | <ul style="list-style-type: none"> • Svuotare la timoneria e smontarla. Togliere i raccordi e pulire le filettature dall'olio. Posizionare il fluido sigilla raccordi, avvitare i raccordi, installare la timoneria. |
| <p>Perdite d'olio dai raccordi della timoneria.</p> | <p>⚠ AVVERTENZA Per sigillare i raccordi non utilizzare in nessun caso nastro teflon o nastro adesivo.</p> | <p>⚠ AVVERTENZA Dopo questa operazione, è necessario procedere ad una nuova operazione di spurgo completa.</p> |
| <p>Perdite d'olio dal tappo del serbatoio.</p> | <ul style="list-style-type: none"> • Tappo avvitato male. | <ul style="list-style-type: none"> • Avvitare il tappo. |
| <p>Perdite d'olio dal tappo del serbatoio.</p> | <ul style="list-style-type: none"> • Tappo con sfiato posto sulla timoneria supplementare posizionata più in basso. | <ul style="list-style-type: none"> • Sostituire il tappo sfiato col tappo per kit timoneria supplementare. |
| <p>Perdite d'olio dal tappo del serbatoio.</p> | <ul style="list-style-type: none"> • Guarnizione di tenuta usurata o danneggiata. | <ul style="list-style-type: none"> • Sostituire il tappo. |
| <p>Perdite d'olio dal tappo del serbatoio.</p> | <ul style="list-style-type: none"> • Livello dell'olio troppo abbondante. | <ul style="list-style-type: none"> • Applicare la procedura di mantenimento livello olio descritta nel manuale della pompa |



6 SMANTELLAMENTO

6.1 Smantellamento

Qualora si intenda, per qualsiasi motivo, mettere fuori servizio il sistema di guida, è necessario osservare alcune regole fondamentali atte a salvaguardare l'ambiente.

Guaine, condotti flessibili, componenti di materiale plastico o comunque non metallico, dovranno essere smontati e smaltiti separatamente.

*Il sistema di guida **CONTIENE OLII INQUINANTI**
che devono essere smaltiti secondo le normative
in vigore.*

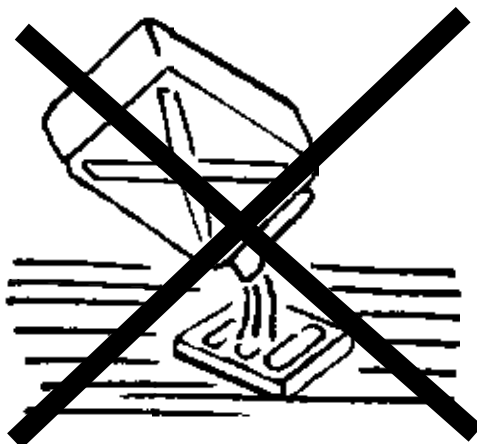

Manuel d'installation et d'entretien

POMPE POUR SYSTEMES DE GOUVERNEMENT HYDRAULIQUES

UP25 F
UP28 F
UP33 F
UP39 F
UP45 F
UP25NV F
UP33NV F

UP28 R
UP33 R
UP39 R
UP39-I R
UP45 R
UP45-I R

UP25 T
UP28 T
UP33 T
UP39 T
UP45 T

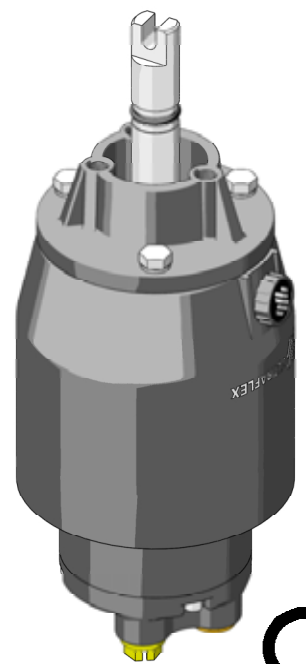
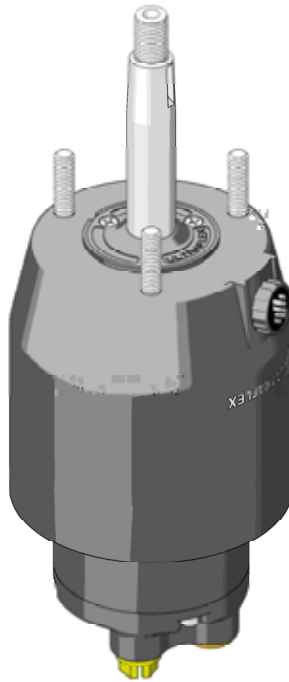

FRANÇAIS

CE



ULTRAFLEX



ASSOCIE





Cher Client,

Nous vous remercions pour avoir choisi un produit **ULTRAFLEX**.

La Société **ULTRAFLEX** est depuis plusieurs années un point de repère dans les systèmes de gouvernement dans le domaine de la navigation de plaisance et professionnelle.
La production **ULTRAFLEX** est depuis toujours une garantie de grande fiabilité et sécurité.

Tous les produits **ULTRAFLEX** sont conçus et fabriqués pour assurer toujours les performances les meilleures.

Pour assurer votre sécurité et pour maintenir toujours un niveau de qualité élevé **ULTRAFLEX** ne garantit ses produits que si les pièces de rechange originales sont utilisées (voir annexe "Application Spare Parts").

Les Systèmes de Gestion de la Qualité **ULTRAFLEX** et **UFLEX** sont certifiés CISQ-IQNet par le Registre Italien des Navires (RINA), en conformité avec la Norme UNI EN ISO 9001:2008. Certificat **ULTRAFLEX** n° 6669/02/S (ancien 420/96). Certificat **UFLEX** n°8875/03/S.

Le système Qualité implique toutes les ressources et les processus d'entreprise à partir de la conception du projet au but de:

- assurer au client la qualité du produit;
- maintenir et améliorer continuellement les standard de qualité;
- poursuivre une amélioration continue de l'efficacité des processus afin de répondre toujours aux exigences du marché et d'augmenter la satisfaction des Clients;

Le système de Gestion Environnementale de la Qualité **ULTRAFLEX** est certifié CISQ-IQNet par le Registre Italien des Navires (RINA), en conformité avec la Norme UNI EN ISO 14001. Certificat **ULTRAFLEX** n° EMS-1282/S.

Vérifier la conformité des produits aux prescriptions de la directive 2013/53/EU.



"**ULTRAFLEX**, avec plus de 80 années d'expérience dans le domaine nautique, est aujourd'hui une industrie de pointe sur échelle mondiale dans la production de systèmes de gouvernement mécaniques, hydrauliques, électroniques, boîtes de commande et volants pour bateaux moteur pour la plaisance, la pêche ou le travail de toutes les dimensions et types de motorisations.

La fiabilité de nos produits et le service pré-vente et après-vente, la qualité de l'organisation de l'entreprise et des ressources humaines aussi bien que les investissements continus dans la recherche et le développement sont des facteurs fondamentaux pour expliquer le succès croissant de nos produits dans le monde entier".

ULTRAFLEX S.p.A.

16015 Casella (Genova) Italia - Via Crose, 2

INDEX GENERAL



| | |
|---|----|
| INDEX DES REVISIONS DU DOCUMENT | 72 |
| EMPLOI DU MANUEL ET SYMBOLES UTILISES | 73 |
| LETTRE D'INFORMATION | 74 |
| GARANTIE | 74 |

SECTION 1 - DESCRIPTION DU PRODUIT



| | |
|---|----|
| 1.1 FONCTIONNEMENT D'UN SYSTEME DE GOUVERNEMENT HYDRAULIQUE | 75 |
| 1.2 AVERTISSEMENTS POUR L'EMPLOI CORRECT DU PRODUIT | 75 |
| 1.3 CONFIGURATIONS DU SYSTEME | 76 |
| 1.4 DESCRIPTION DES POMPES | 76 |
| 1.5 CARACTERISTIQUES TECHNIQUES DES POMPES | 77 |

SECTION 2 - TRANSPORT



| | |
|-----------------------------------|----|
| 2.1 AVERTISSEMENTS GENERAUX | 80 |
| 2.2 CONTENU EMBALLAGE | 80 |

SECTION 3 - INSTALLATION



| | |
|---|----|
| 3.1 OUTILS NECESSAIRES POUR L'INSTALLATION DES POMPES UP25 F - UP28 F -UP33 F - UP39 F - UP45 F - UP25NV F - UP33NV F | 83 |
| 3.2 INSTALLATION DES POMPES UP25 F - UP28 F -UP33 F - UP39 F - UP45 F - UP25NV F - UP33NV F | 83 |
| 3.3 OUTILS NECESSAIRES POUR L'INSTALLATION DES POMPES UP28 R -UP33 R - UP39 R - UP45 R | 85 |
| 3.4 INSTALLATION DES POMPES UP28 R -UP33 R - UP39 R - UP45 R | 85 |
| 3.5 OUTILS NECESSAIRES POUR L'INSTALLATION DES POMPES UP39-I R - UP45-I R | 87 |
| 3.6 INSTALLATION DES POMPES UP39-I R - UP45-I R | 87 |
| 3.7 OUTILS NECESSAIRES POUR L'INSTALLATION DES POMPES UP25 T - UP28 T -UP33 T - UP39 T - UP45 T | 89 |
| 3.8 INSTALLATION DES POMPES UP25 T - UP28 T -UP33 T - UP39 T - UP45 T | 89 |
| 3.9 TYPES D'INSTALLATION | 92 |
| 3.10 CONNEXION DES TUYAUX AU SYSTEME | 93 |
| 3.10.1 CONNEXION DES TUYAUX AU SYSTEME MODELES UP25 F-R-T, UP28 F-R-T, UP33 F-R-T, UP39 F-R-T, UP45 F-R-T | 93 |
| 3.10.2 CHOIX DES TUYAUX RIGIDES POUR LES MODELES UP39-I R ET UP 45-I R | 94 |
| 3.10.3 CONNEXION DES TUYAUX AU SYSTEME MODELES UP39-I R ET UP45-I R | 95 |
| 3.11 REMPLISSAGE ET PURGE | 96 |
| 3.11.1 POSITIONNEMENT DE LA BOUTEILLE DE L'HUILE | 97 |
| 3.11.2 PROCEDURE DE PURGE | 97 |
| 3.12 RECOMMANDATION GENERALE | 97 |

SECTION 4 - AVERTISSEMENTS DE SECURITE



| | |
|---|----|
| 4.1 NORMES DE SECURITE PENDANT L'INSTALLATION ET L'EMPLOI | 98 |
| 4.2 HABILLEMENT | 98 |

SECTION 5 - ENTRETIEN



| | |
|--------------------------------|----|
| 5.1 ENTRETIEN ORDINAIRE | 99 |
| 5.2 DESASSEMBLAGE VOLANT | 99 |
| 5.3 RECHERCHE DES PANNES | 99 |

SECTION 6 - DEMOLITION



| | |
|----------------------|-----|
| 6.1 DEMOLITION | 101 |
|----------------------|-----|





INDEX DES REVISIONS DU DOCUMENT

| Rév. | Date | Description de la révision |
|-------------|-------------|---|
| 0 | 10/02/2012 | Première réalisation |
| 1 | 20/11/2012 | Ajout des modèles 45 F - R - I R - T et modification raccords orientables |
| 2 | 30/07/2013 | Ajout du modèle 39-I R |
| 3 | 28/02/2014 | Corrections des références figures aux pages 76 et 77 |
| 4 | 16/07/2014 | Modification des chapitres "Contenu emballage" et "Positionnement de la bouteille de l'huile" |

EMPLOI DU MANUEL ET SYMBOLES UTILISES

Le MANUEL D'INSTALLATION ET D'ENTRETIEN est le document qui accompagne le produit de sa vente jusqu'à son remplacement et sa démolition. C'est donc une partie fondamentale du manuel lui-même. Il faut lire le manuel avant TOUTE ACTIVITE concernant le produit y compris sa manutention et son déchargement du moyen de transport.

Les symboles ci-dessous ont été adoptés dans le manuel afin d'assurer la sécurité de l'utilisateur et le fonctionnement correct du produit.

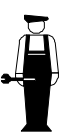
-  **DANGER** → Dommages immédiats qui CAUSENT des blessures graves à la personne ou qui en provoquent la mort.
-  **AVERTISSEMENT** → Il indique qu'il y a un danger qui peut provoquer des lésions ou la mort si on n'adoptent pas les précautions appropriées.
-  **ATTENTION** → Il indique un appel à l'application de pratiques de sécurité ou il appelle l'attention sur des pratiques non sûres qui pourraient causer des lésions personnelles ou des dommages au bateau ou aux composants ou à l'environnement.
-  **NOTE** → Information importante pour une installation adéquate et pour l'entretien, qui ne cause pas de dommages.
-  → Les opérations pour l'exécution desquelles on demande du personnel qualifié ou spécialisé, afin d'éviter toute sorte de risques, sont indiquées avec le symbole à côté. On recommande de former le personnel préposé à l'installation du produit et de vérifier si ce qui est prévu a été compris et mis en œuvre.

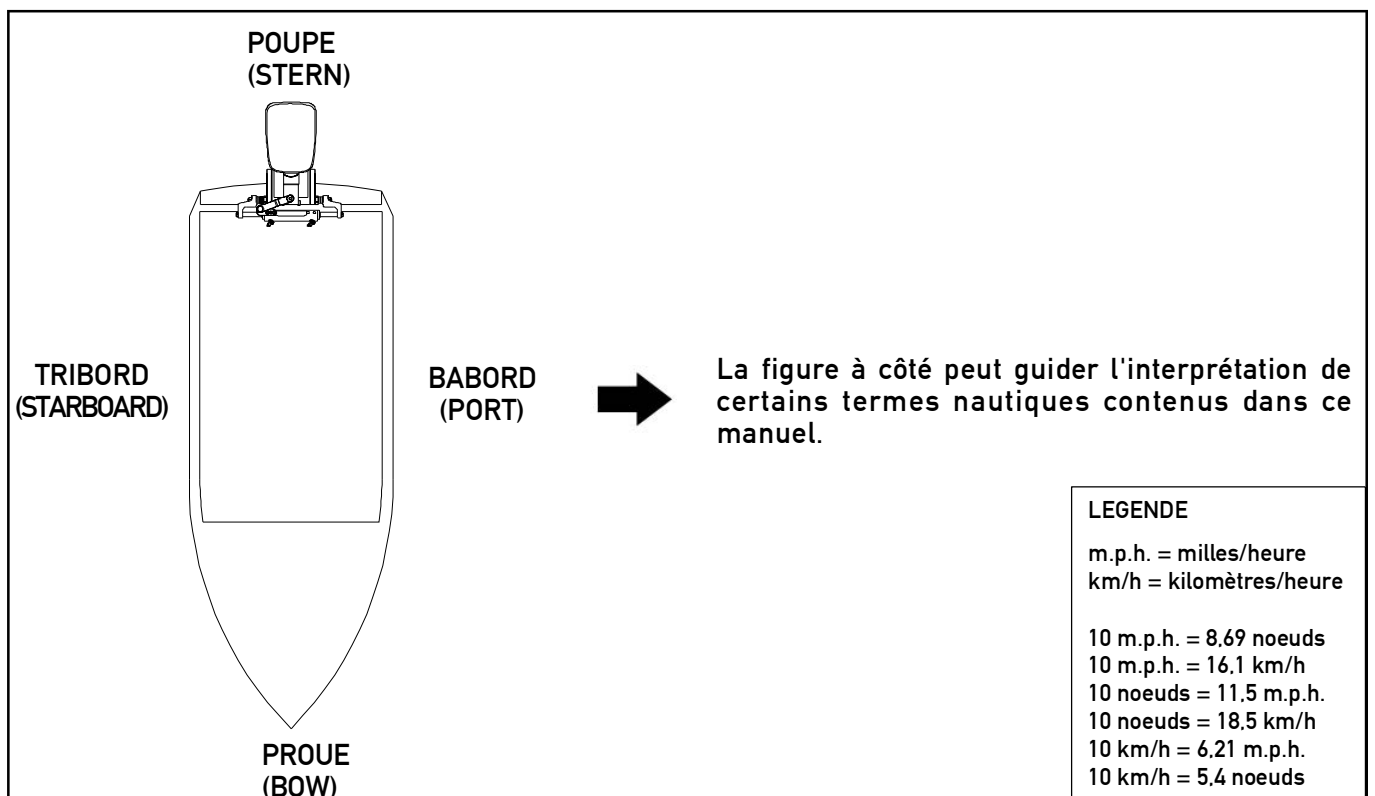

FRANÇAIS



LETTRE D'INFORMATION

Ce manuel d'installation et d'entretien est une partie intégrante du produit et il doit être facilement repérable par le personnel préposé à son emploi et à son entretien.

L'utilisateur doit connaître le contenu de ce manuel.

La Société **ULTRAFLEX** décline toute responsabilité en cas d'inexactitudes dues à des fautes d'impression, contenues dans le manuel. Bien que les caractéristiques principales du type de produit décrit ne changent pas, la Société **ULTRAFLEX** se réserve le droit de modifier les descriptions, les détails et les illustrations qu'elle jugera nécessaires afin de l'améliorer, soit pour des exigences de caractère constructif ou commercial, dans n'importe quel moment et sans être obligé de mettre à jour le manuel tout de suite.

TOUS LES DROITS SONT RESERVES. Les droits de publication, les marques, les sigles et les photos des produits **ULTRAFLEX** contenus dans ce manuel appartiennent à la Société **ULTRAFLEX** qui en interdit toute sorte de reproduction même partielle. Tous les soins ont été pris pour rassembler et contrôler la documentation contenue dans ce manuel afin de le rendre le plus complet et le plus compréhensible possible. Rien de ce qui est contenu dans cette publication ne peut être interprété comme garantie ou condition explicite ou implicite - y compris, pas en voie limitative, la garantie d'aptitude pour un but particulier. Rien de ce qui est contenu dans cette publication ne peut être interprété comme modification ou assertion des termes de n'importe quel contrat d'achat.

⚠ AVERTISSEMENT

Le produit doit être installé par du personnel formé afin d'assurer son fonctionnement correct et celui de ses composants. En cas de rupture de parties ou de mauvais fonctionnement, s'adresser au personnel spécialisé ou contacter notre Service d'Assistance Technique.

SERVICE D'ASSISTANCE TECHNIQUE

UFLEX S.r.l.

Via Milite Ignoto,8A
16012 Busalla (GE)-Italia
Tél: +39.010.962.01
Fax: +39.010.962.0333
Email: ut@ultraflexgroup.it
www.ultraflexgroup.it

Amérique du nord - du sud - centrale:

UFLEX USA

6442 Parkland Drive
Sarasota, FL 34243
Tél: +1.941.351.2628
Fax: +1.941.360.9171
Email: uflex@uflexusa.com
www.uflexusa.com

GARANTIE

La Société **ULTRAFLEX** garantit que ses produits sont fabriqués à règles d'art et qu'ils n'ont aucun défaut de fabrication et de matériels.

Cette garantie a une validité de deux années à partir de la date de fabrication des produits à l'exception des cas où ils sont installés et utilisés sur des bateaux de travail ou de commerce, car alors la garantie est limitée à une année de la date de fabrication.

Dans le cas où, pendant cette période le produit s'avérerait défectueux à cause des matériaux utilisés ou/et présente des vices de fabrication, le fabricant le remplacera ou le réparera gratuitement.

Tout autre dommage direct ou indirect est exclu de la garantie. En particulier la Société constructrice n'est pas responsable et cette garantie ne couvre pas les dommages dérivant d'une installation incorrecte ou d'un emploi inadéquat ou abusif des produits (à l'exception du remplacement ou de la réparation des pièces défectueuses dans les termes et les délais susmentionnés) .

Cette garantie ne couvre pas les produits installés sur des bateaux de course ou utilisés pour des compétitions. Les descriptions et les illustrations contenues dans ce manuel sont seulement à titre indicatif.

Pour toute information détaillée contacter notre Service d'Assistance.

Les composants des systèmes de conduite **ULTRAFLEX** sont pourvus de la marque **CE** en conformité avec la directive 2013/53/EU.

On rappelle que sur les bateaux pourvus de la marque **CE** il est obligatoire d'installer des systèmes de gouvernement dont les composants sont marqués **CE**. Nous vous informons que la garantie **ULTRAFLEX** échoit automatiquement au cas où certains composants **ULTRAFLEX** seraient installés dans un système de gouvernement avec des produits de marques différentes.



1 DESCRIPTION DU PRODUIT

1.1 Fonctionnement d'un système de gouvernement hydraulique

Les systèmes de gouvernement hydrauliques **ULTRAFLEX** sont conçus en conformité avec la norme UNI-EN-ISO 10592 et la norme A.B.Y.C. P21.

Les systèmes de gouvernement **ULTRAFLEX** sont à même de fonctionner avec des températures ambiantes entre -18°C (0°F) et +77°C (+170°F). Tous leurs composants ont été réalisés spécifiquement pour le milieu marin, à l'aide de matériels et de procédés de fabrication offrant une longue durée et un haut degré de sécurité même dans des conditions extrêmes. Le système de gouvernement hydraulique dans un bateau est formé d'une pompe placée sur le tableau de bord, d'un vérin à poupe connecté au moteur ou au gouvernail et des tuyaux hydrauliques de connexion (voir figure). La rotation du volant provoque le pompage de l'huile qui, selon le sens de rotation, coule à travers les tuyaux jusqu'à atteindre le vérin.

Le mouvement du vérin fait refluer l'huile vers la pompe à travers les tuyaux et en même temps déplace le moteur ou le gouvernail du bateau connectés au vérin lui-même. La soupape de non-retour dont les pompes sont équipées, empêche l'écoulement de l'huile à la pompe si elle n'est pas activée et permet le fonctionnement des systèmes avec deux ou plusieurs postes de gouvernement. Les pompes série "NV" ne sont pas pourvues de soupape de non-retour et donc elles ne peuvent pas être utilisées avec deux ou plusieurs postes de gouvernement.

Les vérins sont à double effet et ils peuvent être équilibrés ou pas équilibrés. Dans les vérins pas équilibrés les deux chambres ont des volumes différents et donc elles demandent un nombre différent de tours du volant et un effort de rotation différent sur le volant à déplacement égal dans les deux directions. Les vérins pas équilibrés ne peuvent pas être utilisés avec les pompes série "NV". Les vérins équilibrés demandent le même nombre de tours du volant pour déplacer le gouvernail du centre au fin de course dans les deux directions opposées. Un système de gouvernement équilibré et facile à manoeuvrer demande un choix correct du type de pompe à accoupler au vérin. **ULTRAFLEX** produit plusieurs modèles de pompes, dont les différences sont le débit (cm³ d'huile déplacés à chaque tour du volant) et le type d'installation. Quand on choisit la pompe il faut considérer le volume du vérin. En effet le nombre de tours du volant de gauche à droite est déterminé par le rapport entre le volume du vérin et le débit de la pompe.

Exemple: si la pompe a un débit de 28 cm³ [1.7cu.in.] et le vérin a un volume de 120 cm³ [7.3cu.in.], la formule suivante est appliquée: $120/28=4,2$. Le volant tournera donc environ 4 fois avant que le vérin ne soit complètement déplacé d'un côté à l'autre. En cas d'installations avec deux vérins connectés en parallèle il faut additionner le volume des vérins. Les accouplements avec moins de 4 tours qui demandent un effort de conduite excessif ou avec plus de 8 tours qui retardent la réponse du bateau à la direction ne sont pas recommandables.

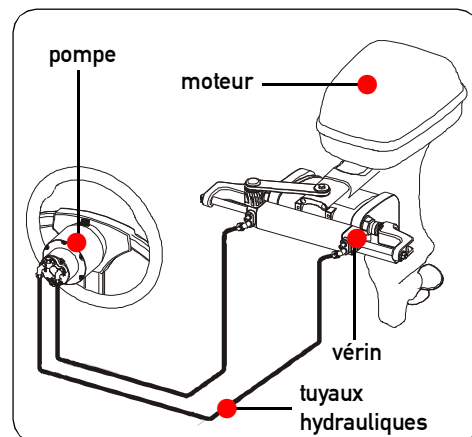

1.2 Avertissements pour l'emploi correct du produit

⚠ DANGER

En tout cas ne pas modifier la pompe pour l'adapter à votre application sinon la pompe ne fonctionnera pas en sécurité et elle sera dangereuse pour le bateau et pour ses occupants.

⚠ AVERTISSEMENT

Les systèmes de gouvernement **ULTRAFLEX** ne doivent pas être appliqués sur des bateaux équipés de motorisations dépassant les puissances maximales installables établies par le chantier.

⚠ AVERTISSEMENT

Les systèmes de gouvernement hydrauliques **ULTRAFLEX** ne sont pas conseillés pour être installés sur les bateaux de course.

⚠ AVERTISSEMENT

Les pompes UP25NV F et UP33NV F ne peuvent pas être utilisées avec des vérins non équilibrés et ne peuvent pas être utilisées avec un poste double.



1.3 Configurations du système

Les pompes modèle UP25 - UP28 - UP33 - UP39 -UP45 peuvent être installées dans un système de gouvernement unique ou double et utilisées avec différents types de configurations de vérins à assemblage frontal, latéral ou in-bord.

Les pompes série "NV" ne peuvent pas être installées dans un système de gouvernement double et ne peuvent pas être utilisées avec des vérins pas équilibrés.

⚠ ATTENTION

Connecter toujours avec attention les tuyaux comme indiqué dans les manuels d'installation et d'entretien des vérins hydrauliques correspondants.

1.4 Description des pompes

Les pompes UP25 - UP28 - UP33 - UP39 - UP45 ont été conçues et fabriquées pour être utilisées comme composant d'un système de gouvernement hydraulique comme décrit au paragraphe précédent.

Les pompes UP25 F - UP28 F - UP33 F - UP39 F - UP45 F - UP25NV F - UP33NV F doivent être assemblées sur la partie frontale du tableau de bord du bateau ou semi-encastrables à l'aide deS brideS X64 ou X57 (fournie séparément), les pompes UP28 R - UP33 R - UP39 R - UP39-I R - UP45 R - UP45-I R doivent être assemblées sur la partie postérieure du tableau de bord du bateau et les pompes UP25 T - UP28 T - UP33 T - UP39 T - UP45 T doivent être assemblées à l'aide du tilt X52 (fourni séparément).

Les figures ci-dessous montrent les composants principaux des pompes:

- | | |
|---|---|
| <ul style="list-style-type: none"> ❶ Pompe UP25 F - UP28 F - UP33 F - UP39 F - UP45 F - UP25NV F - UP33NV F ❷ Bouchon réservoir avec évent ❸ Arbre de connexion volant ❹ Connexions de raccordement au/aux vérin/vérins ❺ Connexions de raccordement postes supplémentaires (non utilisables avec la série "NV") | <ul style="list-style-type: none"> ❻ Goujons M6 pour fixation au tableau de bord ❼ Pompe UP28 R - UP33 R - UP39 R - UP39-I R - UP45 R - UP45-I R ❽ Goujons M8 pour fixation au tableau de bord ❾ Pompe UP25 T - UP28 T - UP33 T - UP39 T - UP45 T ❿ Arbre de connexion au tilt X52 |
|---|---|

UP25 F - UP28 F - UP33 F - UP39 F - UP45 F - UP25NV F - UP33NV F

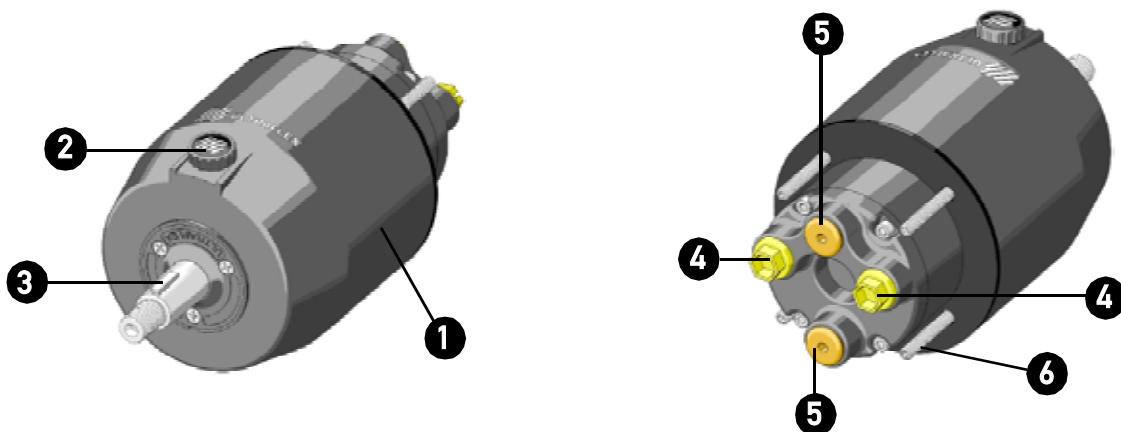

UP28 R - UP33 R - UP39 R - UP39-I R - UP45 R - UP45-I R

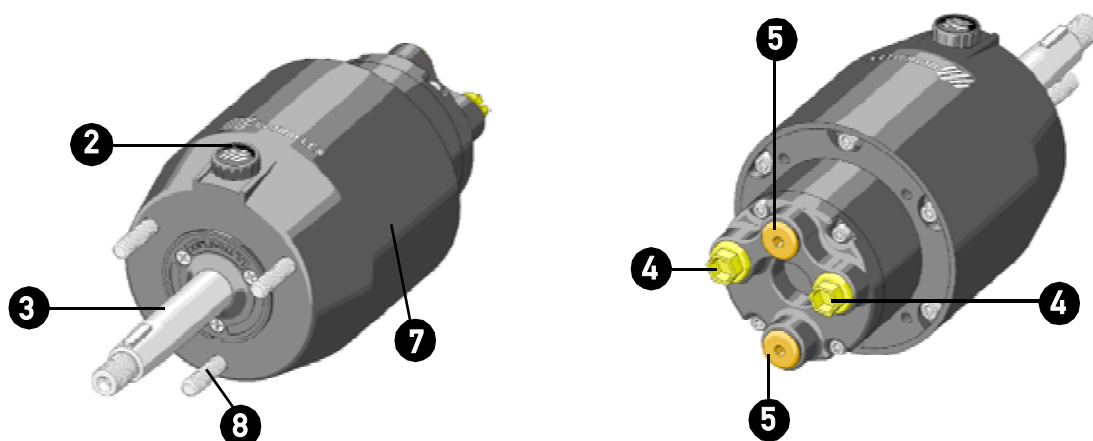

UP25 T - UP28 T - UP33 T - UP39 T - UP45 T

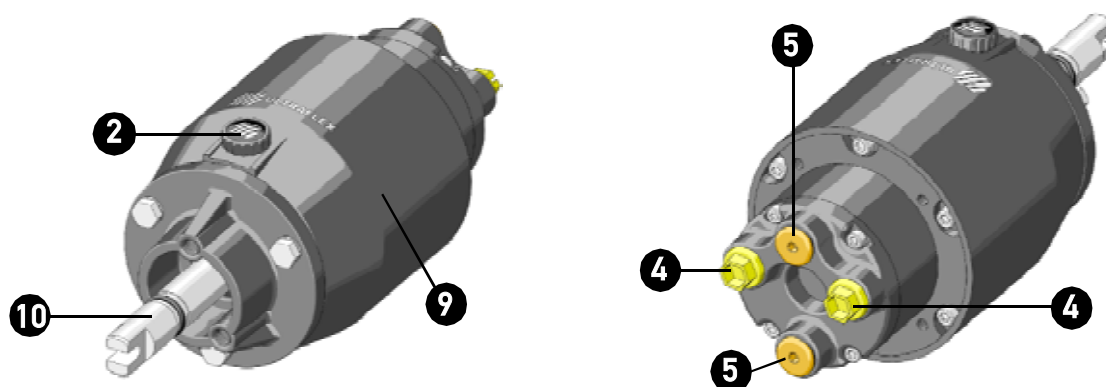

1.5 Caractéristiques techniques des pompes

| SPECIFICATIONS | POMPE UP25 F | POMPE UP25NV F | POMPE UP28 F | POMPE UP33 F | POMPE UP33NV F | POMPE UP39 F | POMPE UP45 F |
|---|-------------------------------|-------------------------------|-----------------------------|-----------------------------|-----------------------------|-----------------------------|-----------------------------|
| Débit | 23,5 cc/tour - 1,4 cu.in/tour | 23,5 cc/tour - 1,4 cu.in/tour | 28 cc/tour - 1,7 cu.in/tour | 33 cc/tour - 2,0 cu.in/tour | 33 cc/tour - 2,0 cu.in/tour | 39 cc/tour - 2,4 cu.in/tour | 45 cc/tour - 2,7 cu.in/tour |
| Pression de relâchement des soupapes de surpression | 70 bar (1000 psi) | 70 bar (1000 psi) | 70 bar (1000 psi) | 70 bar (1000 psi) | 70 bar (1000 psi) | 70 bar (1000 psi) | 70 bar (1000 psi) |
| N° pistons | 5 | 5 | 5 | 7 | 7 | 7 | 7 |
| Diamètre max. volant | 711 mm (28 in.) | 711 mm (28 in.) | 711 mm (28 in.) | 711 mm (28 in.) | 711 mm (28 in.) | 711 mm (28 in.) | 711 mm (28 in.) |
| Hauteur max. volant | 152 mm (6 in.) | 152 mm (6 in.) | 152 mm (6 in.) | 152 mm (6 in.) | 152 mm (6 in.) | 152 mm (6 in.) | 152 mm (6 in.) |
| Poids | 5 kg (11 lbs) | 5 kg (11 lbs) | 5 kg (11 lbs) | 5 kg (11 lbs) | 5 kg (11 lbs) | 5 kg (11 lbs) | 5 kg (11 lbs) |
| Huile | OL150 Ultraflex | OL150 Ultraflex | OL150 Ultraflex | OL150 Ultraflex | OL150 Ultraflex | OL150 Ultraflex | OL150 Ultraflex |

⚠ ATTENTION

La pression de relâchement des soupapes de surpression ne correspond pas à la pression d'emploi normale du système mais elle représente la condition limite d'emploi.



UP25 F - UP28 F - UP33 F - UP39 F - UP45 F - UP25NV F - UP33NV F

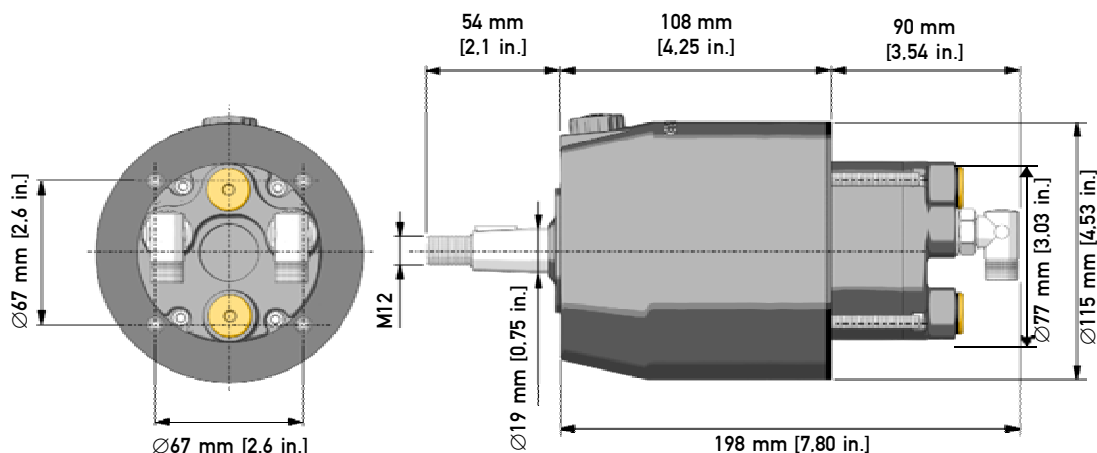

| SPECIFICATIONS | POMPE UP28 R | POMPE UP33 R | POMPE UP39 R | POMPE UP45 R | POMPE UP45-I R |
|---|-----------------------------|-----------------------------|-----------------------------|-----------------------------|-----------------------------|
| Débit | 28 cc/tour - 1,7 cu.in/tour | 33 cc/tour - 2,0 cu.in/tour | 39 cc/tour - 2,4 cu.in/tour | 45 cc/tour - 2,7 cu.in/tour | 45 cc/tour - 2,7 cu.in/tour |
| Pression de relâchement des soupapes de surpression | 70 bar (1000 psi) | 70 bar (1000 psi) | 70 bar (1000 psi) | 70 bar (1000 psi) | 70 bar (1000 psi) |
| N° pistons | 5 | 7 | 7 | 7 | 7 |
| Diamètre max. volant | 711 mm (28 in.) | 711 mm (28 in.) | 711 mm (28 in.) | 711 mm (28 in.) | 711 mm (28 in.) |
| Hauteur max. volant | 152 mm (6 in.) | 152 mm (6 in.) | 152 mm (6 in.) | 152 mm (6 in.) | 152 mm (6 in.) |
| Poids | 5 kg (11 lbs) | 5 kg (11 lbs) | 5 kg (11 lbs) | 5 kg (11 lbs) | 5 kg (11 lbs) |
| Huile | OL150 Ultraflex | OL150 Ultraflex | OL150 Ultraflex | OL150 Ultraflex | OL150 Ultraflex |

⚠ ATTENTION

La pression de relâchement des soupapes de surpression ne correspond pas à la pression d'emploi normale du système mais elle représente la condition limite d'emploi.

UP28 R - UP33 R - UP39 R - UP45 R

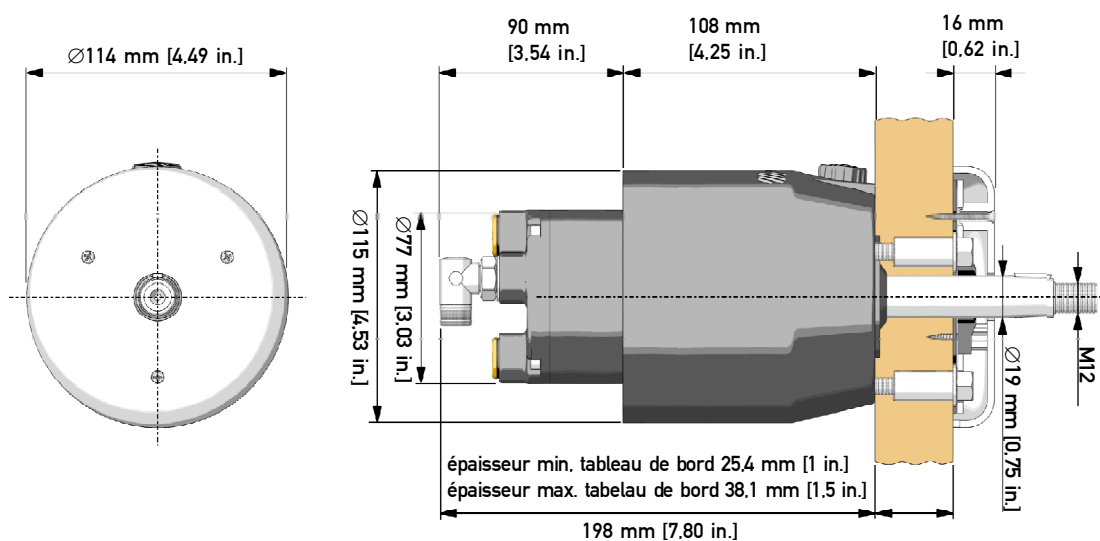

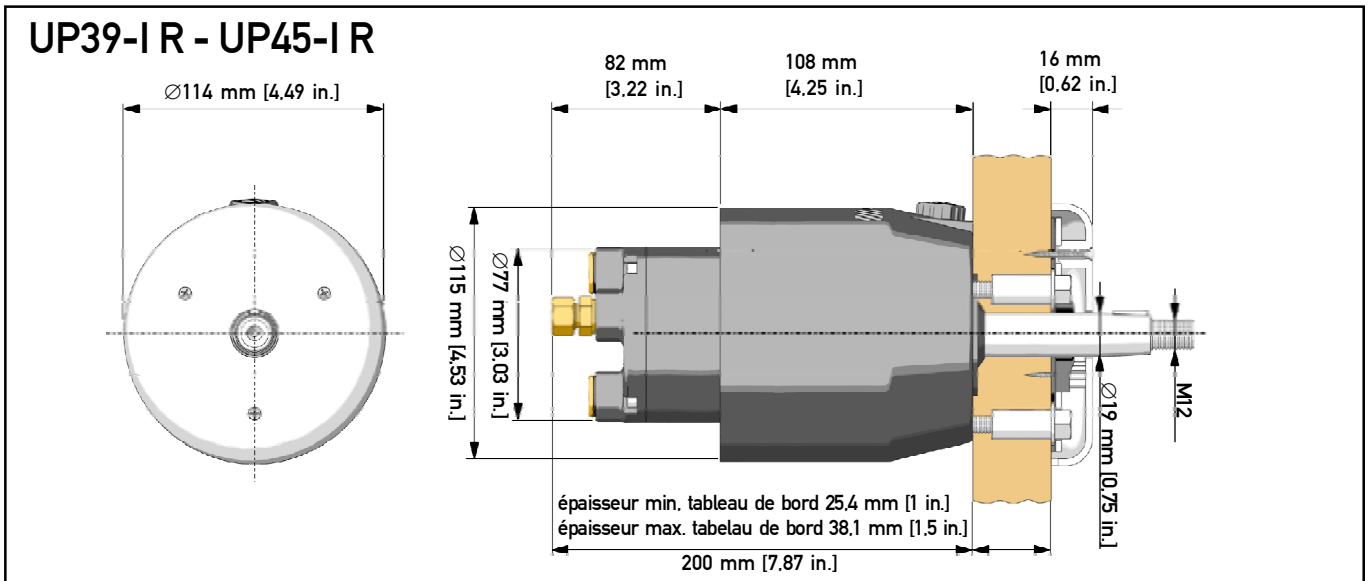

| SPECIFICATIONS | POMPE UP25 T | POMPE UP28 T | POMPE UP33 T | POMPE UP39 T | POMPE UP45 T |
|---|-----------------------------|-----------------------------|-----------------------------|-----------------------------|-----------------------------|
| Débit | 25 cc/tour - 1,5 cu.in/tour | 28 cc/tour - 1,7 cu.in/tour | 33 cc/tour - 2,0 cu.in/tour | 39 cc/tour - 2,4 cu.in/tour | 45 cc/tour - 2,7 cu.in/tour |
| Pression de relâchement des soupapes de surpression | 70 bar (1000 psi) | 70 bar (1000 psi) | 70 bar (1000 psi) | 70 bar (1000 psi) | 70 bar (1000 psi) |
| N° pistons | 5 | 5 | 7 | 7 | 7 |
| Diamètre max. volant | 406 mm (16 in.) | 406 mm (16 in.) | 406 mm (16 in.) | 406 mm (16 in.) | 406 mm (16 in.) |
| Hauteur max. volant | 152 mm (6 in.) | 152 mm (6 in.) | 152 mm (6 in.) | 152 mm (6 in.) | 152 mm (6 in.) |
| Poids | 5 kg (11 lbs) | 5 kg (11 lbs) | 5 kg (11 lbs) | 5 kg (11 lbs) | 5 kg (11 lbs) |
| Huile | OL150 Ultraflex | OL150 Ultraflex | OL150 Ultraflex | OL150 Ultraflex | OL150 Ultraflex |

⚠ ATTENTION

La pression de relâchement des soupapes de surpression ne correspond pas à la pression d'emploi normale du système mais elle représente la condition limite d'emploi.

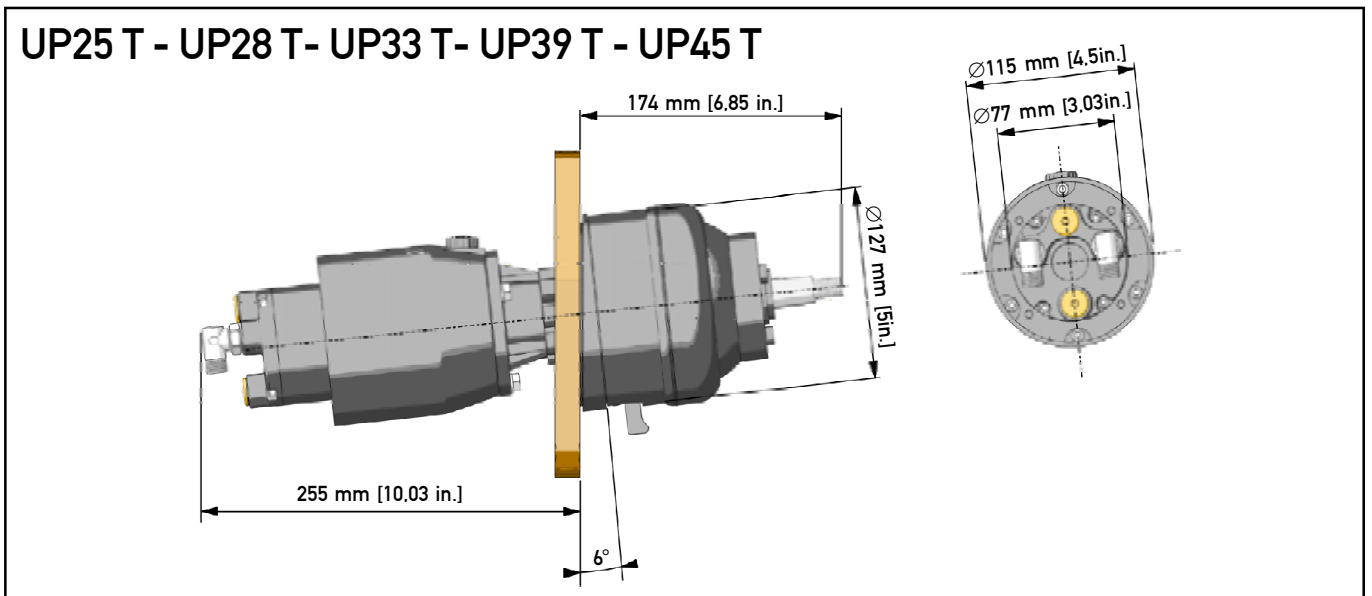

⚠ ATTENTION

Les pompes UP25 T - UP28 T - UP33 T - UP39 T - UP45 T peuvent être utilisées seulement avec le tilt **ULTRAFLEX X52** (fourni séparément).



2 TRANSPORT

2.1 Avertissements généraux

Le poids des pompes UP25-UP28-UP33-UP39-UP45 avec leur emballage est 5 Kg (11 pounds). Elles peuvent donc être déplacées manuellement.

⚠ AVERTISSEMENT

Le personnel chargé de la manipulation du chargement doit porter des gants de protection et des chaussures de sécurité.

2.2 Contenu emballage

Avant d'utiliser l'appareillage s'assurer qu'il ne soit pas endommagé à cause du transport ou des conditions de conservation. Vérifier aussi que tous les composants fournis de série soient dans l'emballage (voir liste). En cas d'endommagement, notifier la réclamation au transporteur et informer votre fournisseur.

UP25 F - UP28 F - UP33 F - UP39 F - UP45 F - UP25NV F - UP33NV F

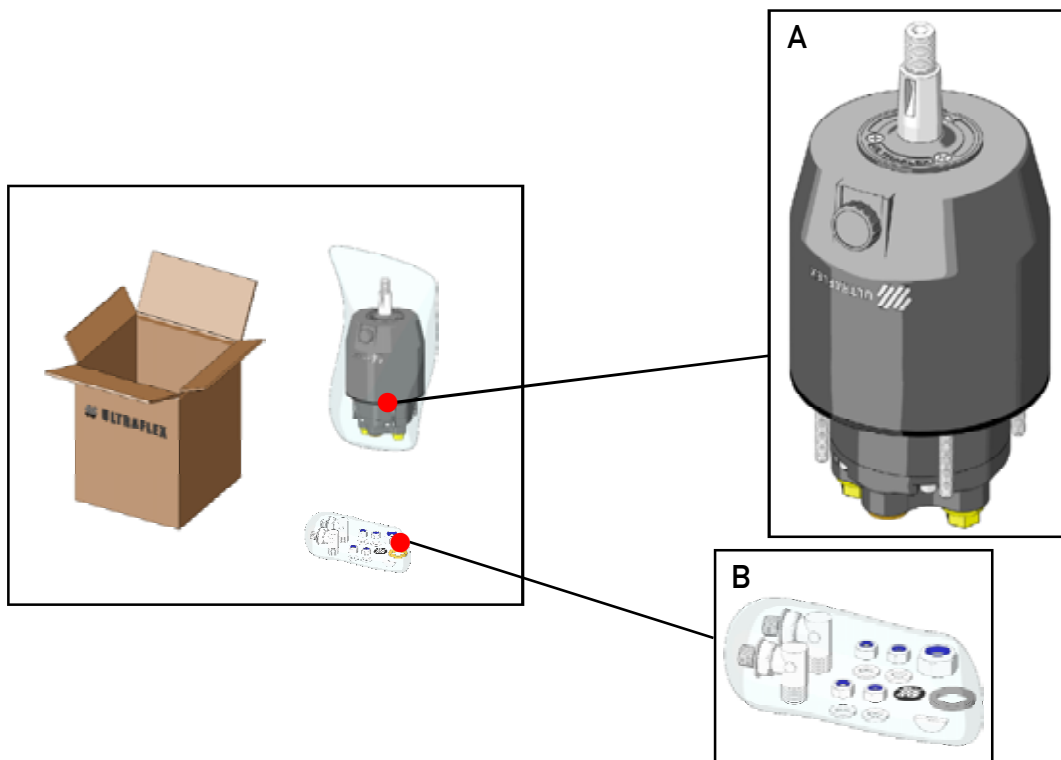

CONTENU DE L'EMBALLAGE STANDARD:

- A) n°1 pompe UP25 F ou UP28 F ou UP33 F ou UP39 F ou UP45 F ou UP25NV F ou UP33NV F pourvue de joint pour la fixation au tableau de bord.
- B) n°2 raccords orientables à 90° pour la connexion des tuyaux Kit OB (fournis séparément);
 - n°4 écrous pour la fixation au tableau de bord;
 - n°4 rondelles pour la fixation au tableau de bord;
 - n°1 écrou pour le serrage du volant;
 - n°1 rondelle pour le serrage du volant;
 - n°1 clavette pour le serrage du volant;
 - n°1 étiquette pour bouchon.



UP28 R - UP33 R - UP39 R - UP39-I R- UP45 R - UP45-I R

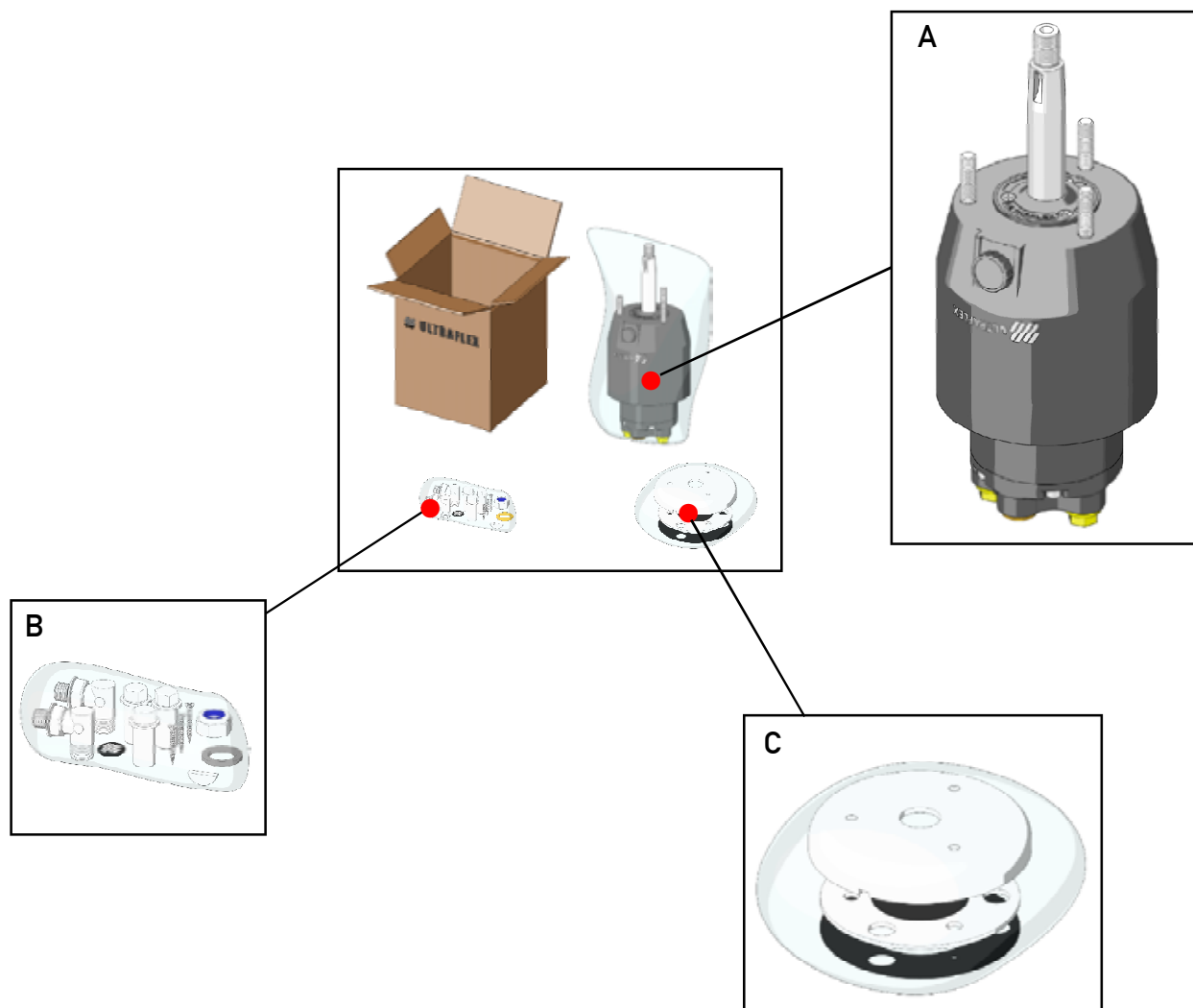

CONTENU DE L'EMBALLAGE STANDARD:

A) n°1 pompe UP28 R ou UP33 R ou UP39 R ou UP39-I R ou UP45 R ou UP45-I R.

B) n°2 raccords orientables à 90° (sauf les pompes UP39-I R et UP45-I R) pour la connexion des tuyaux Kit OB (fournis séparément);
 n°3 vis spéciales pour la fixation au tableau de bord;
 n°3 vis autotaraudeuses pour la fixation du couvre-moyeu;
 n°1 écrou pour le serrage du volant;
 n°1 rondelle pour le serrage du volant;
 n°1 clavette pour le serrage du volant;
 n°1 étiquette pour bouchon.

C) n°1 garniture;
 n°1 bride;
 n°1 couvre-moyeu.

NOTE

Les versions UP39-I R et UP45-I R sont fournies avec le raccord spécial 1/4 NPT droit pour le tuyau métallique Ø 12 mm.

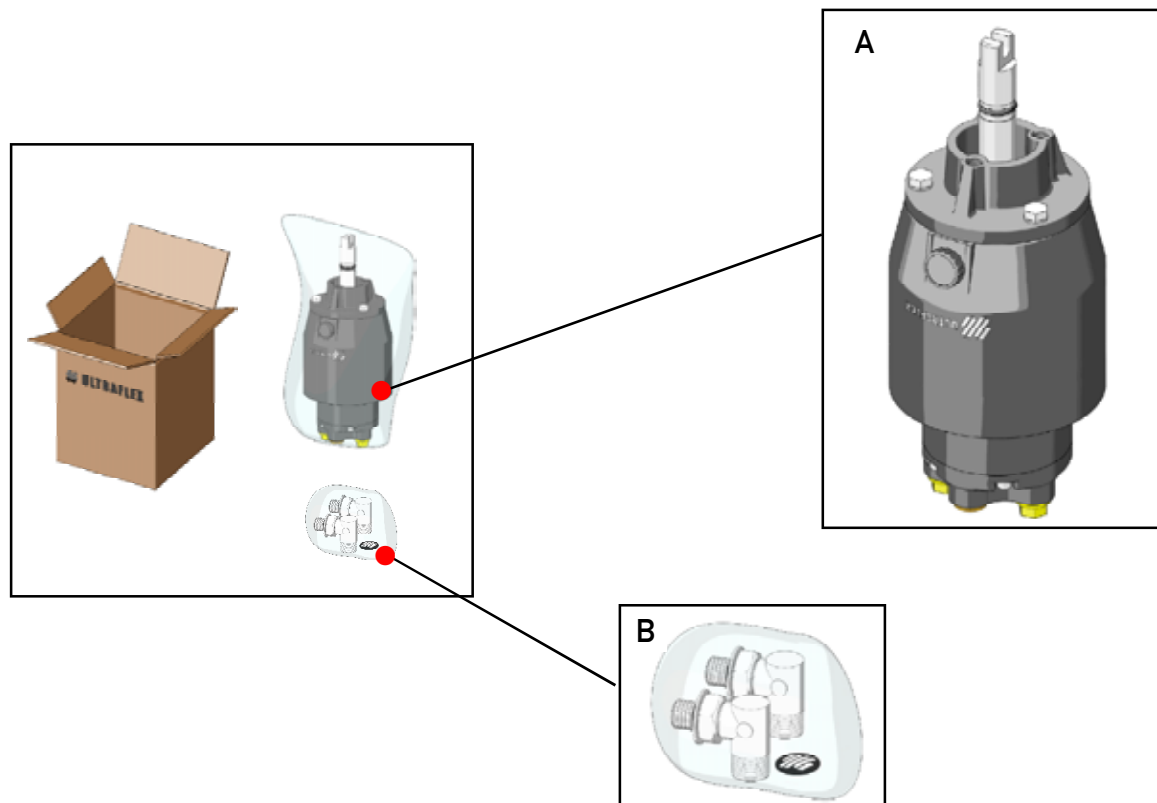

UP25 T - UP28 T - UP33 T - UP39 T - UP45 T**CONTENU DE L'EMBALLAGE STANDARD:**

A) n°1 pompe UP25 T ou UP28 T ou UP33 T ou UP39 T ou UP45 T.

B) n°2 raccords orientables à 90° pour la connexion des tuyaux Kit OB (fournis séparément);
n°1 étiquette pour bouchon.

ATTENTION

L'emballage doit être éliminé en conformité avec les directives en vigueur.



3 INSTALLATION

3.1 Outils nécessaires pour l'installation des pompes UP25 F - UP28 F - UP33 F - UP39 F - UP45 F - UP25NV F - UP33NV F

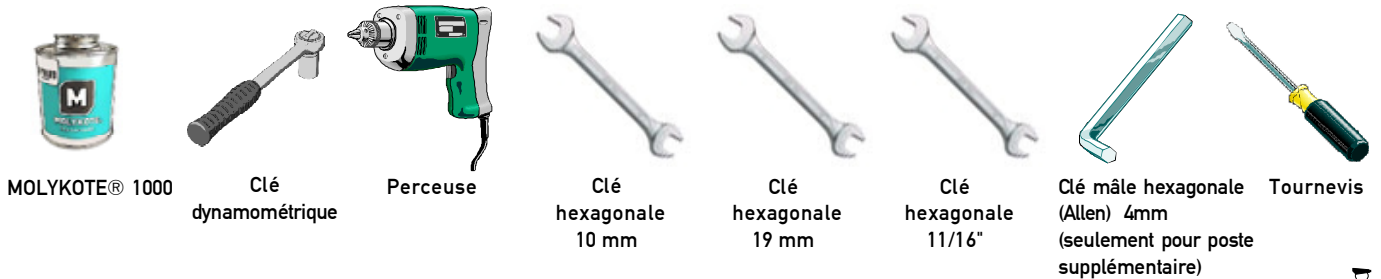

3.2 Installation des pompes UP25F-UP28F-UP33F-UP39F-UP45F-UP25NVF-UP33NVF

1 Choisir une position adéquate pour l'installation du poste de gouvernement. S'assurer que l'espace soit suffisant pour manoeuvrer le volant et qu'il y ait de l'espace pour la pompe et pour ses tuyaux et raccords.

⚠ AVERTISSEMENT

Pour fixer correctement la pompe, l'épaisseur maximale du tableau de bord doit être 30 mm [1,18 in.]. Toute épaisseur différente pourrait compromettre la sécurité de la conduite. S'assurer que l'anneau de freinage des 4 écrous autofreinés fournis soit engagé par le filet des goujons.

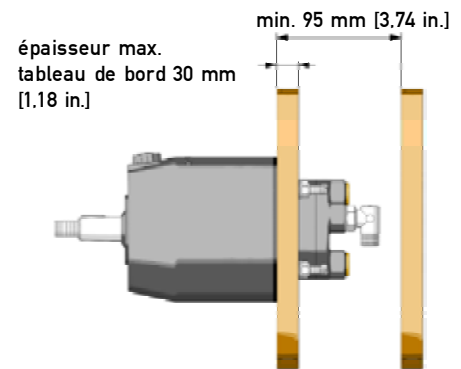

2 Enlever les bouchons (1) de la pompe (2) à l'aide d'un tournevis.

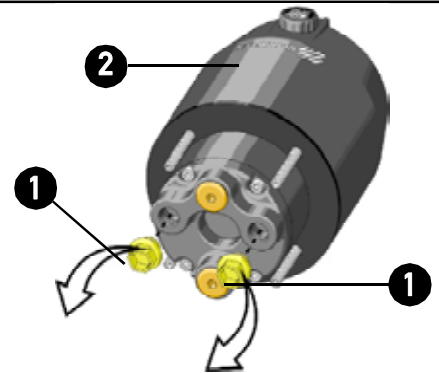

3 Visser complètement les écrous sur les raccords relatifs à 90° (3). Placer et visser les raccords manuellement comme indiqué dans la figure jusqu'à les insérer totalement, les orienter jusqu'à les positionner dans la façon la plus adéquate à la connexion des tuyaux en les dévissant au maximum d'un tour. Après serrer les écrous à l'aide d'une clé six pans de 11/16" avec un couple de 17,6 Nm (13 lb ft) jusqu'à porter la rondelle en contact avec l'écrou.

⚠ AVERTISSEMENT

NE PAS UTILISER de téflon ou n'importe quel autre type de ruban adhésif.
N'UTILISER aucun type de produit d'étanchéité pour raccords filetés comme Loctite 542 ou produits similaires.

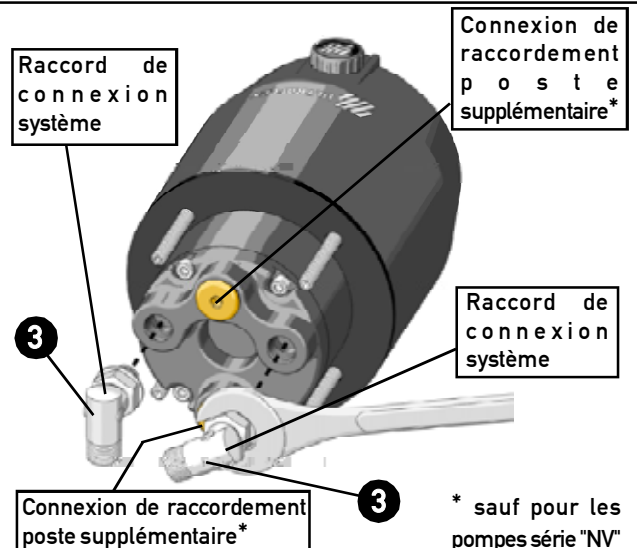

4 Percer sur le tableau de bord en position adéquate les trous (4) nécessaires pour l'installation à l'aide du gabarit adéquat joint à ce manuel.

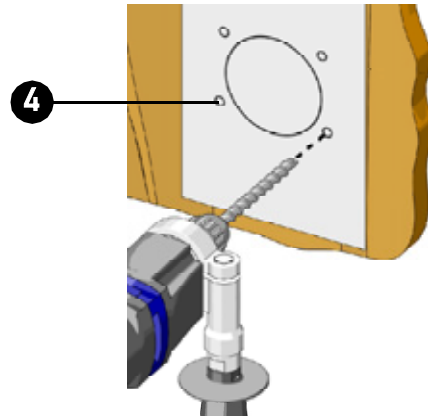

5 Positionner la pompe (2) de la partie frontale du tableau de bord (5) en interposant la garniture (6) et la fixer en insérant les 4 rondelles (7) et en serrant les 4 écrous autofreinés (8) à l'aide d'une clé de 10 mm avec un couple de 10 Nm (7,4 lb ft).

⚠ ATTENTION

Au cas où les écrous autofreinés seraient désassemblés (8), il faudra les remplacer. (Contacter notre service d'assistance, voir page 74).

⚠ AVERTISSEMENT

Installer la pompe avec le trou de remplissage (9) positionné en haut (comme montré dans la figure) pour assurer le fonctionnement correct de la pompe et pour permettre d'effectuer le remplissage complet et la vidange du système (voir par. 3.11).

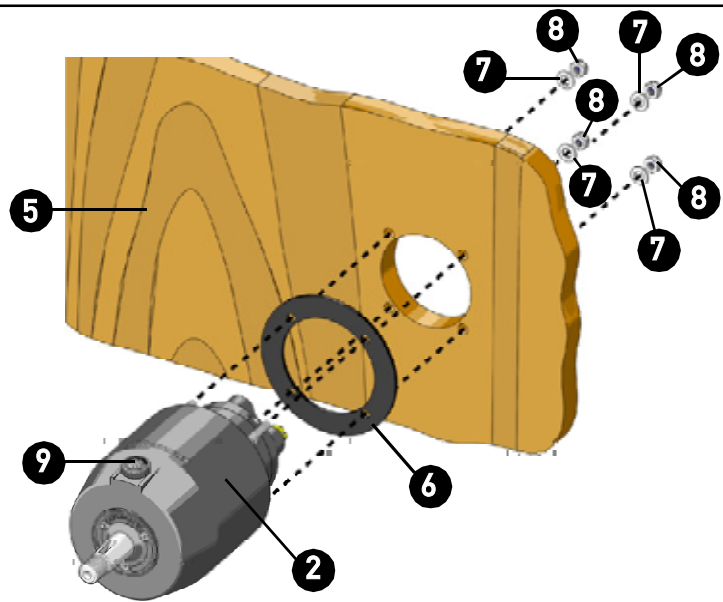

6 Positionner le volant fourni séparément (10) sur l'arbre de la pompe (11) à l'aide de la clavette adéquate (12). Insérer la rondelle (13) et serrer l'écrou autofreiné (14) à l'aide d'une clé hexagonale de 19 mm avec un couple de 40 Nm (29,5 lb ft) en graissant le filetage avec de la graisse antigrippante MOLYKOTE® 1000 ou des produits analogues.

⚠ ATTENTION

En cas de désassemblage de l'écrou autofreiné (14), ce dernier devra être remplacé. (Contacter notre service d'assistance, voir page 74).

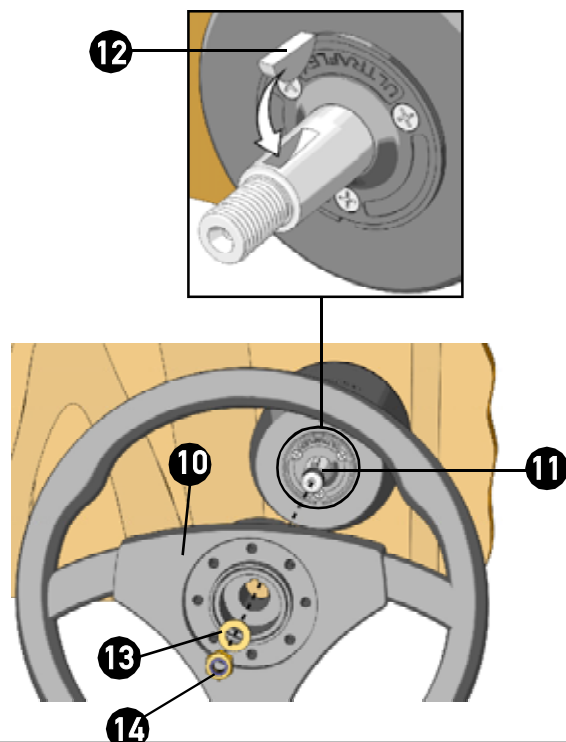

3.3 Outils nécessaires pour l'installation des pompes UP28 R - UP33 R - UP39 R - UP45 R

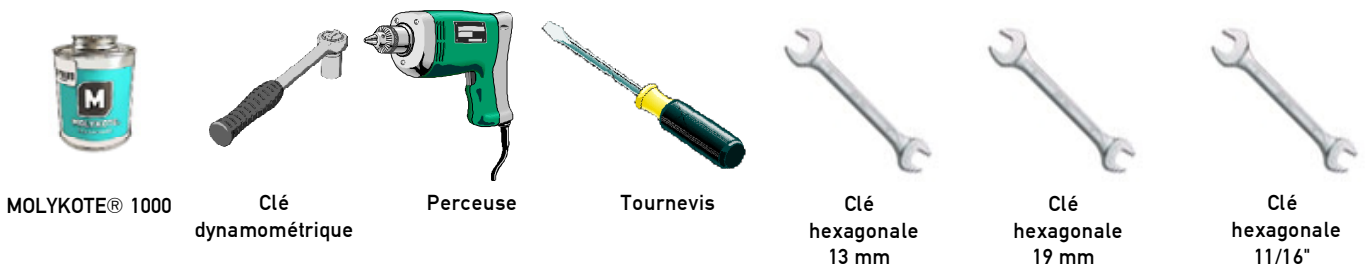

3.4 Installation des pompes UP28 R - UP33 R - UP39 R - UP45 R



1 Choisir une position adéquate pour l'installation du poste de gouvernement. S'assurer que l'espace soit suffisant pour manoeuvrer le volant et qu'il y ait de l'espace pour la pompe et pour ses tuyaux et raccords.

⚠ AVERTISSEMENT

Pour fixer correctement la pompe, l'épaisseur maximale du tableau de bord doit être min. 25,4 mm [1 in.] et max. 38,1 mm [1,5 in.]. Toute épaisseur différente pourrait compromettre la sécurité de la conduite.

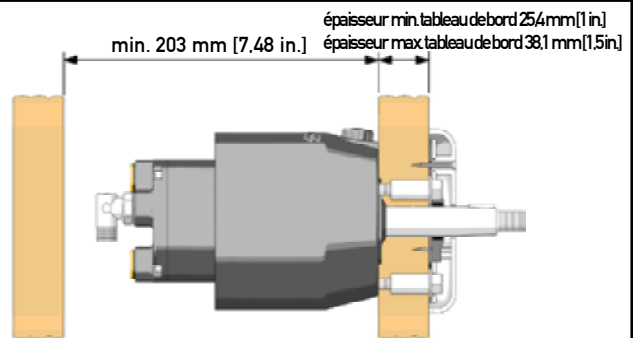

2 Enlever les bouchons (1) de la pompe (2) à l'aide d'un tournevis.

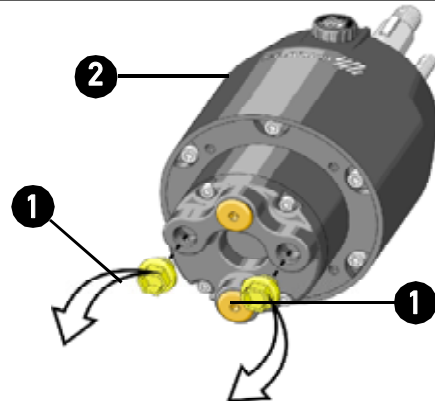

3 Visser complètement les écrous sur les raccords relatifs à 90° (3). Placer et visser les raccords manuellement comme indiqué dans la figure jusqu'à les insérer totalement, les orienter jusqu'à la positionner dans la façon la plus adéquate à la connexion des tuyaux en les dévissant d'un tour au maximum. Après serrer les écrous à l'aide d'une clé six pans de 11/16" avec un couple de 17,6 Nm (13 lb ft) jusqu'à porter la rondelle en contact avec l'écrou.

⚠ AVERTISSEMENT

NE PAS UTILISER de téflon ou n'importe quel autre type de ruban adhésif. N'UTILISER aucun type de produit d'étanchéité pour raccords filetés comme Loctite 542 ou produits similaires.

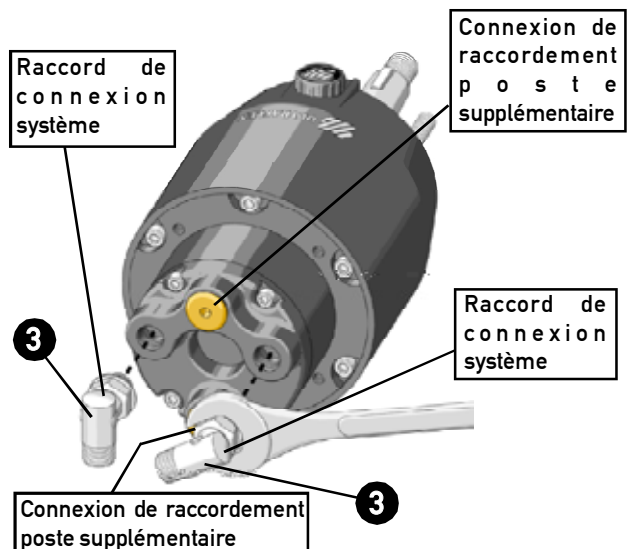

4 Percer sur le tableau de bord en position adéquate les trous nécessaires pour l'installation à l'aide du gabarit adéquat joint à ce manuel.

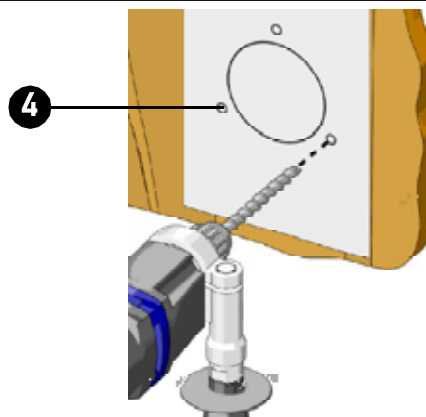

5 Positionner la pompe (2) de la partie postérieure du tableau de bord (5). Ensuite positionner la garniture (6) comme indiqué dans la figure et la bride (7) avec la partie saillante de protection vers l'extérieur du tableau de bord. Fixer la pompe (2) à l'aide des 3 vis spéciales avec un couple de 25 Nm (18,5 lb ft).

⚠ ATTENTION

Passer l'arbre de la pompe à travers la bride pourvue de garniture en faisant en sorte que le logement de la clavette n'endommage pas la garniture elle-même.

⚠ AVERTISSEMENT

Installer la pompe avec le trou de remplissage (9) positionné en haut (comme montré dans la figure) pour assurer le fonctionnement correct de la pompe et pour permettre d'effectuer le remplissage complet et la vidange du système (voir par. 3.11).

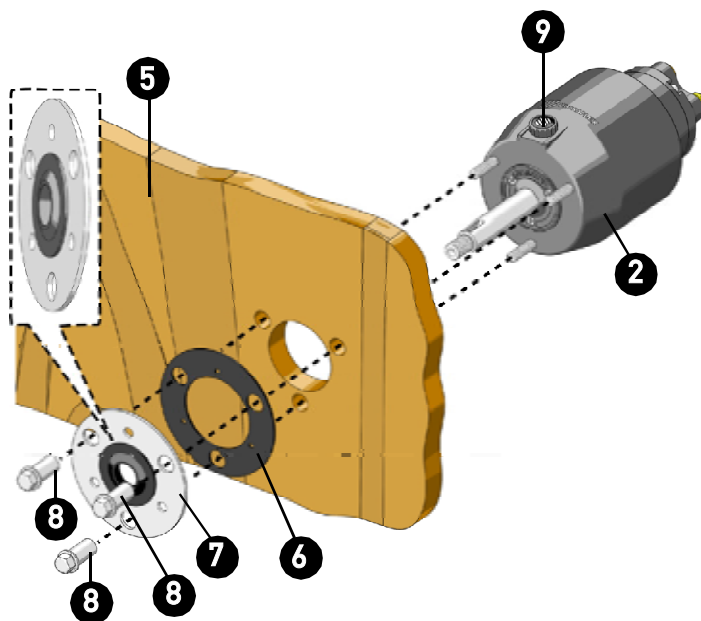

6 Positionner le couvre-moyeu (10) en plastique avec la décharge de l'eau vers le bas et le fixer à l'aide des 3 vis autotaraudeuses (11) fournies avec un couple de 1,5Nm (1,13 lb ft).

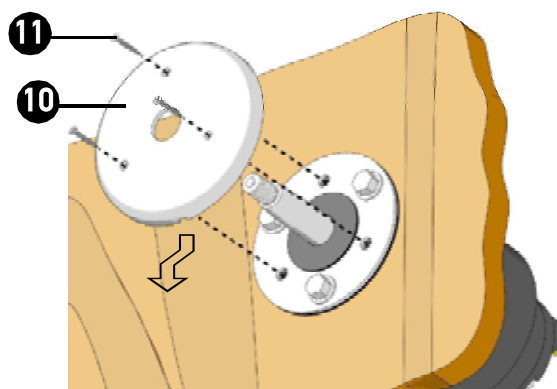

7 Positionner le volant fourni séparément (12) sur l'arbre de la pompe (13) à l'aide de la clavette adéquate (14). Insérer la rondelle (15) et serrer l'écrou autofreiné (16) à l'aide d'une clé hexagonale de 19 mm avec un couple de 40 Nm (29,5 lb ft) en graissant le filetage avec de la graisse antigrippante MOLYKOTE® 1000 ou des produits analogues.

⚠ ATTENTION

En cas de désassemblage de l'écrou autofreiné (16), ce dernier devra être remplacé. (Contacter notre service d'assistance, voir page 74).

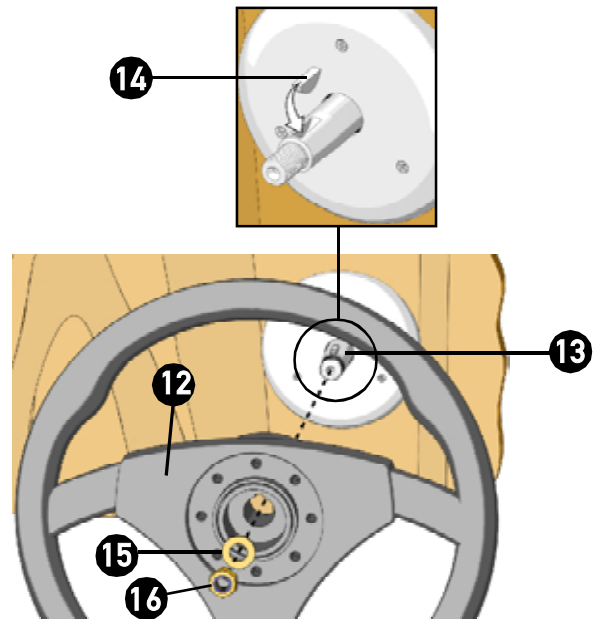

3.5 Outils nécessaires pour l'installation des pompes UP39-I R - UP45-I R



Loctite 542/545



MOLYKOTE® 1000



Clé dynamométrique



Perceuse



Tournevis



Clé hexagonale 13 mm



Clé hexagonale 19 mm



Clé hexagonale 7/16"

3.6 Installation des pompes UP39-I R - UP45-I R



1 Choisir une position adéquate pour l'installation du poste de gouvernement. S'assurer que l'espace soit suffisant pour manoeuvrer le volant et qu'il y ait de l'espace pour la pompe et pour ses tuyaux et raccords.

⚠ AVERTISSEMENT

Pour fixer correctement la pompe, l'épaisseur maximale du tableau de bord doit être min. 25,4 mm [1 in.] et max. 38,1 mm [1,5 in.]. Toute épaisseur différente pourrait compromettre la sécurité de la conduite.

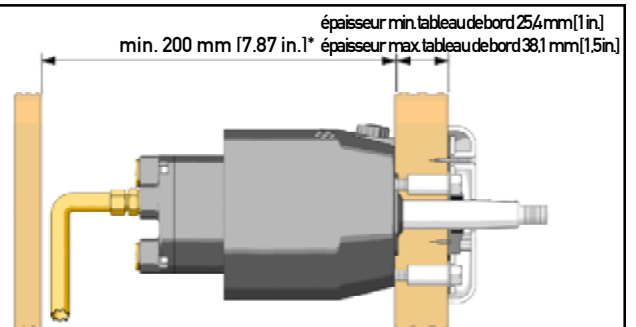

*Cela peut varier selon la position du tuyau

2 Enlever les bouchons (1) de la pompe (2) à l'aide d'un tournevis.

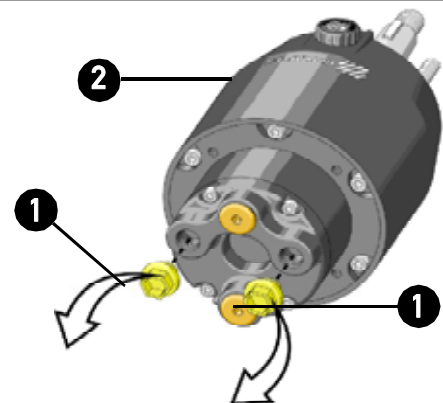

- 3** Appliquer un produit scellant type Loctite 542 ou Loctite 545 sur le filet des raccords. Emboîter et visser manuellement les raccords coniques (3) jusqu'à les insérer complètement; ensuite les serrer à l'aide d'une clé hexagonale de 7/16" avec un couple de serrage de 17,6 Nm (156 lb ft).

⚠ AVERTISSEMENT

Ne pas utiliser de téflon ou n'importe quel autre type de ruban adhésif. Faire très attention au positionnement de la colle pour sceller qui bloquerait le système en le rendant inutilisable si elle était insérée dans le système.

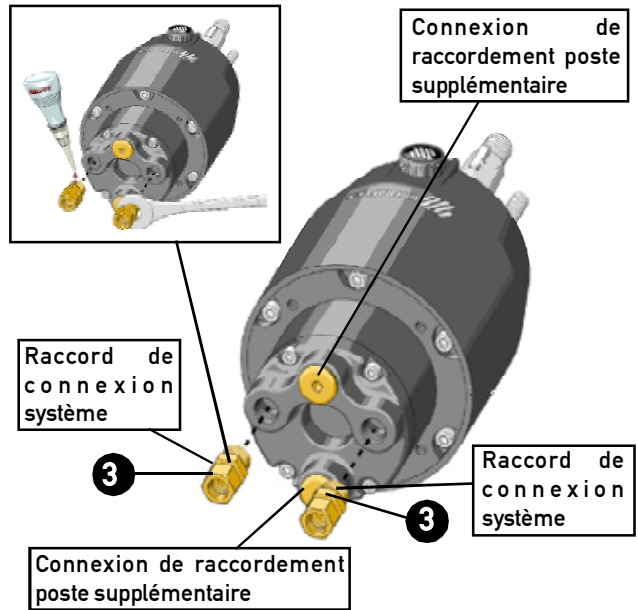

- 4** Percer sur le tableau de bord en position adéquate les trous nécessaires pour l'installation à l'aide du gabarit adéquat joint à ce manuel.

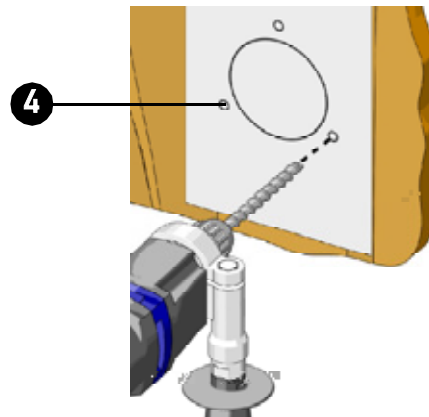

- 5** Positionner la pompe (2) de la partie postérieure du tableau de bord (5). Ensuite positionner la garniture (6) comme indiqué dans la figure et la bride (7) avec la partie saillante de protection vers l'extérieur du tableau de bord. Fixer la pompe (2) à l'aide des 3 vis spéciales avec un couple de 25 Nm (18,5 lb ft).

⚠ ATTENTION

Passer l'arbre de la pompe à travers la bride pourvue de garniture en faisant en sorte que le logement de la clavette n'endommage pas la garniture elle-même.

⚠ AVERTISSEMENT

Installer la pompe avec le trou de remplissage (9) positionné en haut (comme montré dans la figure) pour assurer le fonctionnement correct de la pompe et pour permettre d'effectuer le remplissage complet et la vidange du système (voir par. 3.11).

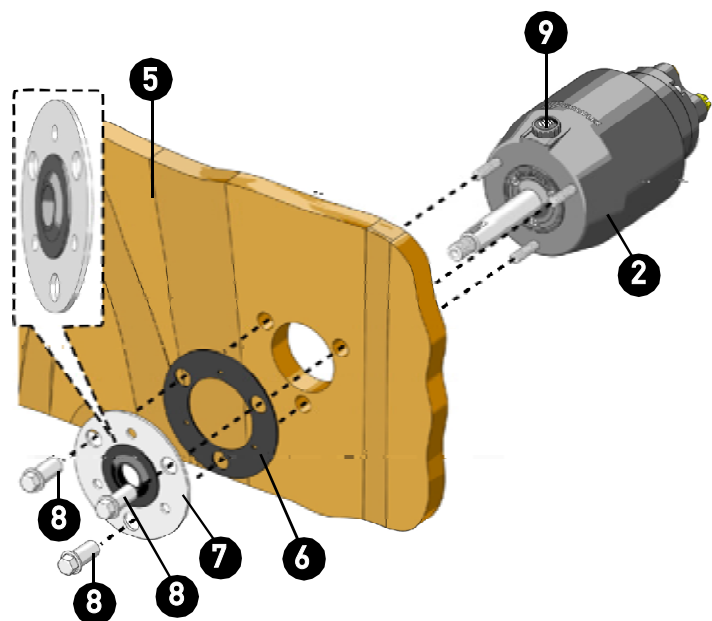

6 Positionner le couvre-moyeu (10) en plastique avec la décharge de l'eau vers le bas et le fixer à l'aide des 3 vis autotaraudeuses (11) fournies.

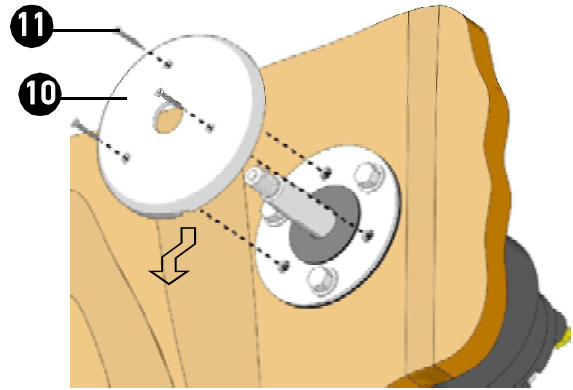

7 Positionner le volant fourni séparément (12) sur l'arbre de la pompe (13) à l'aide de la clavette adéquate (14). Insérer la rondelle (15) et serrer l'écrou autofreiné (16) à l'aide d'une clé hexagonale de 19 mm avec un couple de 40 Nm (29,5 lb ft) en graissant le filetage avec de la graisse antigrippante MOLYKOTE® 1000 ou des produits analogues.

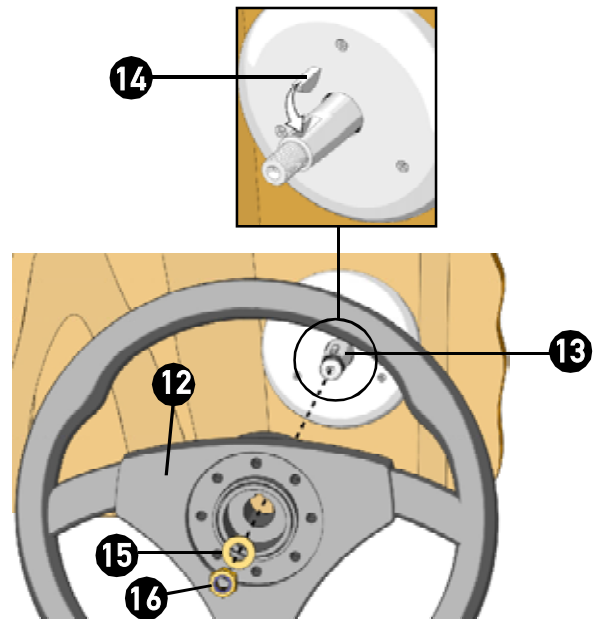

⚠ ATTENTION

En cas de désassemblage de l'écrou autofreiné (16), ce dernier devra être remplacé. (Contacter notre service d'assistance, voir page 74).

3.7 Outils nécessaires pour l'installation des pompes UP25 T - UP28 T - UP33 T - UP39 T - UP45 T



Clé hexagonale 11/16"

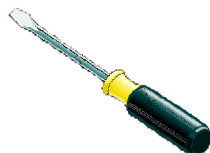

Tournevis

* Les outils pour assembler le tilt X52 sont indiqués dans le manuel joint au tilt X52.

3.8 Installation des pompes UP25 T - UP28 T - UP33 T - UP39 T - UP45 T



⚠ ATTENTION

Le mécanisme tilt X52 est fourni séparément.

1 Choisir une position adéquate pour l'installation du poste de gouvernement. S'assurer que l'espace soit suffisant pour manoeuvrer le volant et qu'il y ait de l'espace pour la pompe et pour ses tuyaux et raccords.

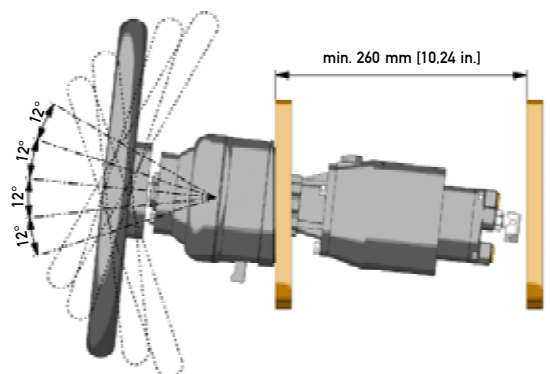

- 2 Enlever les bouchons (1) de la pompe (2) à l'aide d'un tournevis.

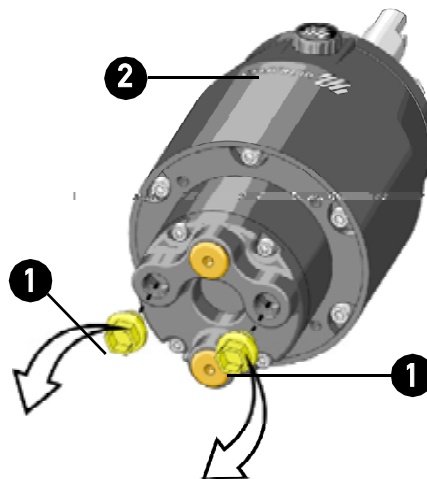

- 3 Fixer l'étrier (3) fourni avec le tilt X52 au tableau de bord (4) selon les instructions jointes au mécanisme tilt X52.

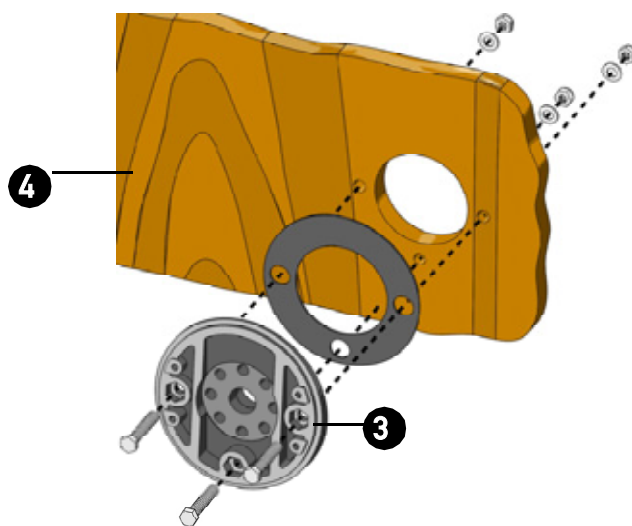

- 4 Visser complètement les écrous sur les raccords relatifs à 90° (3). Placer et visser les raccords manuellement comme indiqué dans la figure jusqu'à les insérer totalement, les orienter jusqu'à les positionner dans la façon la plus adéquate à la connexion des tuyaux en les dévissant d'un tour au maximum. Après serrer les écrous à l'aide d'une clé six pans de 11/16" avec un couple de 17,6 Nm (13 lb ft) jusqu'à porter la rondelle en contact avec l'écrou.

⚠ AVERTISSEMENT

NE PAS UTILISER de téflon ou n'importe quel autre type de ruban adhésif.
N'UTILISER aucun type de produit d'étanchéité pour raccords filetés comme Loctite 542 ou produits similaires.

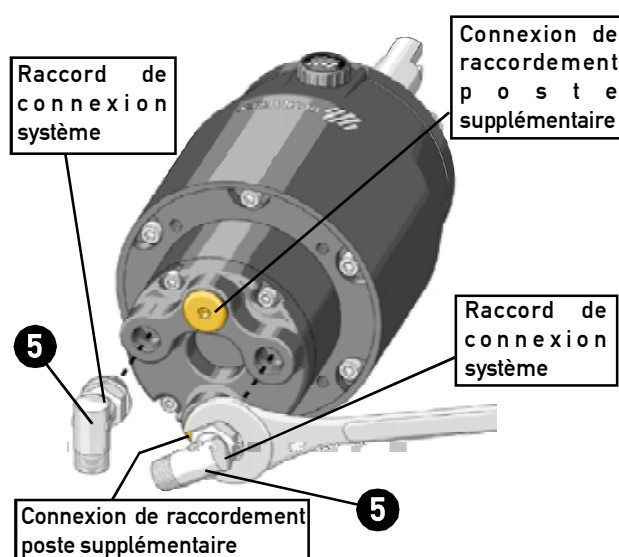

5 Fixer la pompe à l'étrier (3) fourni avec le tilt X52 à l'aide des 3 vis M8 (6) fournies avec le tilt X52 selon les instructions jointes au mécanisme tilt X52.

⚠ AVERTISSEMENT

Installer la pompe avec le trou de remplissage (7) positionné en haut (comme montré dans la figure) pour assurer le fonctionnement correct de la pompe et pour permettre d'effectuer le remplissage complet et la vidange du système (voir par. 3.9).

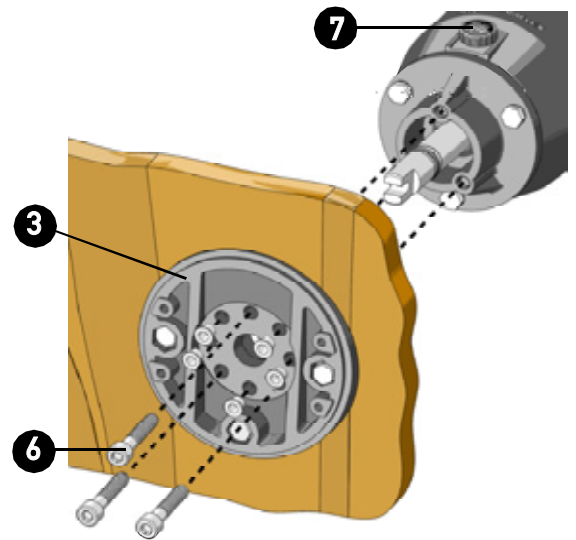

6 Aligner et insérer le joint de cardan du tilt dans l'arbre de la pompe, en desserrant d'environ 1-1,5 tours les vis (8) sur le joint de cardan lui-même et toujours selon la procédure décrite dans le manuel d'installation fourni avec le mécanisme tilt X52. Revisser, serrer les vis (8) et fixer le tilt.

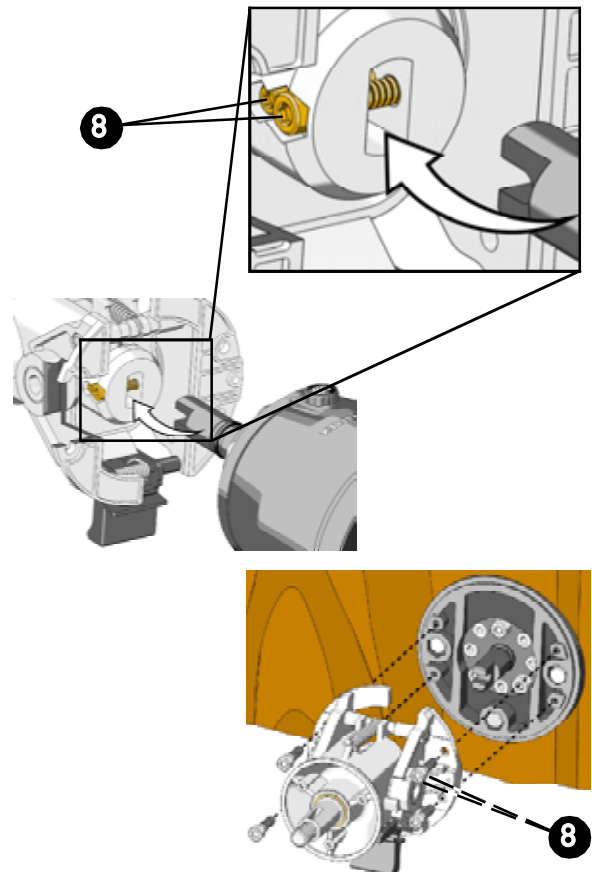

NOTE

Sur les pompes UP28 R-UP33 R-UP39 R- UP39-I R - UP45 R-UP45-I R et UP25 T-UP28 T-UP33 T-UP39 T-UP45 T pour faciliter les opérations de remplissage et de purge du système hydraulique on peut utiliser le kit **ULTRAFLEX** fourni séparément (voir les instructions correspondantes).



3.9 Types d'installation



Les pompes modèle UP25-UP28-UP33-UP39-UP45 peuvent être installées dans un système de gouvernement unique ou double (sauf les pompes série "NV") et utilisées avec différents types de configurations de vérins à assemblage frontal, latéral ou in-bord. Les pompes série "NV" ne peuvent pas être utilisées avec des vérins pas équilibrés.

⚠ ATTENTION

Toujours connecter les tuyaux avec attention comme montré dans les manuels d'installation et d'entretien des vérins hydrauliques correspondants.

MODELES UP 25 F-R-T, UP 28 F-R-T, UP 33 F-R-T, UP 39 F-R-T, UP 45 F-R-T

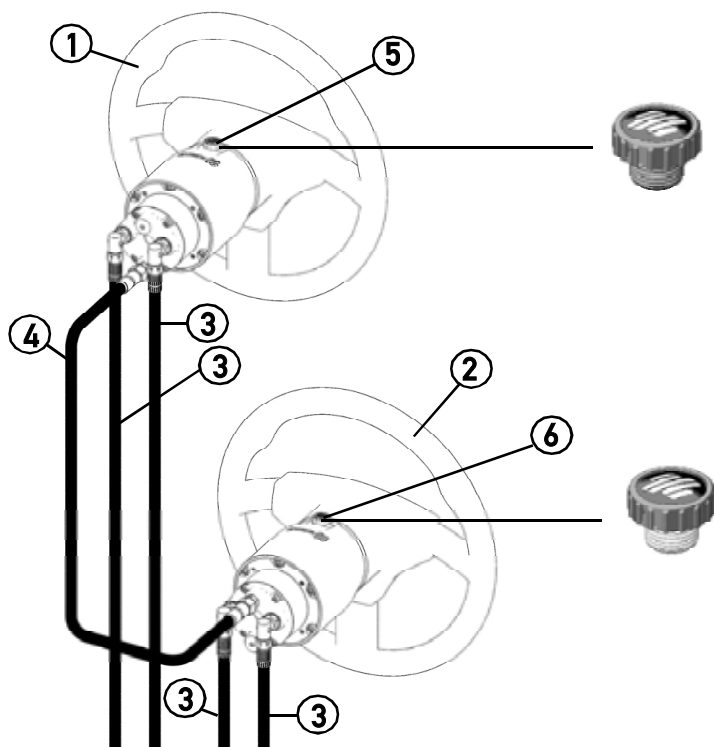

1. poste de gouvernement primaire
2. poste de gouvernement supplémentaire (non utilisable avec les pompes série "NV")
3. kit OB
4. tuyau de 3/8" compris dans le kit OB-2S
5. bouchon d'évent (bouchon noir)
6. bouchon sans évent (bouchon gris)

NOTE

Le Kit OB-2S est fourni séparément pour les applications avec poste double.

MODELES UP 39-I R et UP 45-I R

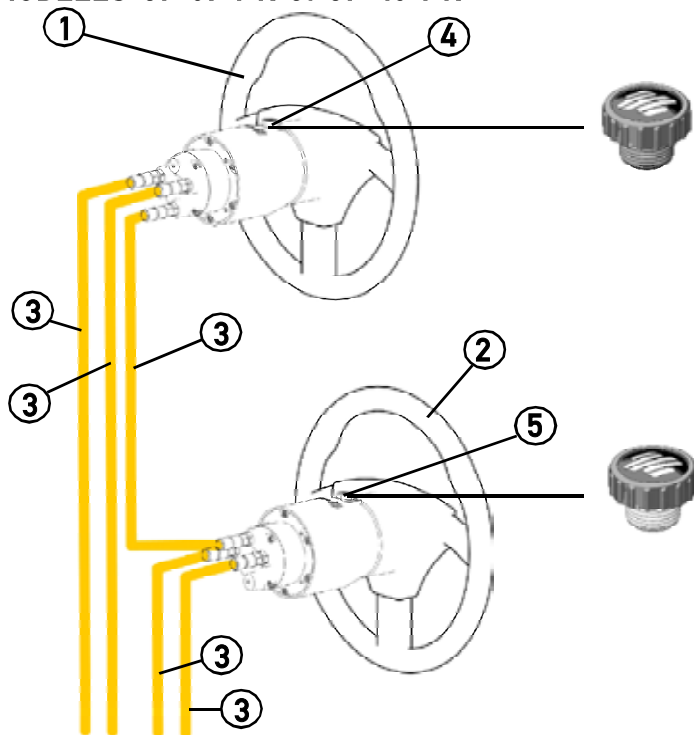

1. poste de gouvernement primaire
2. poste de gouvernement supplémentaire (non utilisable avec les pompes série "NV")
3. tuyau rigide métallique
4. bouchon d'évent (bouchon noir)
5. bouchon sans évent (bouchon gris)

NOTE

Le Kit OB 120 U-2S est fourni séparément pour les applications avec poste double.



3.10 Connexion des tuyaux au système

3.10.1 Connexion des tuyaux au système modèles UP 25 F-R-T, UP 28 F-R-T, UP 33 F-R-T, UP 39 F-R-T, UP 45 F-R-T



- 1 Connecter les tuyaux hydrauliques **ULTRAFLEX** kit OB (fournis séparément) de connexion entre la pompe et le vérin selon les instructions données dans le manuel d'installation du kit OB.
- 2 En cas d'installation d'un ou de plusieurs postes de gouvernement supplémentaires (sauf les pompes série "NV") il faut utiliser le kit OB-2S selon les instructions adéquates.

Positionner les raccords droits de 3/8" (1) sur les pompes comme indiqué dans la figure. Appliquer un produit scellant type Loctite 542 ou Loctite 545 sur le filet des raccords. Emboîter et visser manuellement les raccords coniques (1) jusqu'à les insérer complètement; ensuite les serrer à l'aide d'une clé hexagonale de 7/16" avec un couple de serrage de 17.6 Nm (156 lb ft).

⚠ AVERTISSEMENT

Ne pas utiliser de téflon ou n'importe quel autre type de ruban adhésif. Faire très attention au positionnement de la colle pour sceller qui bloquerait le système en le rendant inutilisable si elle était insérée dans le système.

POSTE DE GOUVERNEMENT PRIMAIRE

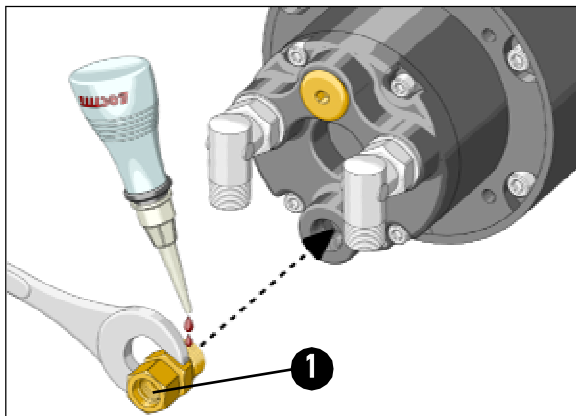

POSTE DE GOUVERNEMENT SUPPLEMENTAIRE

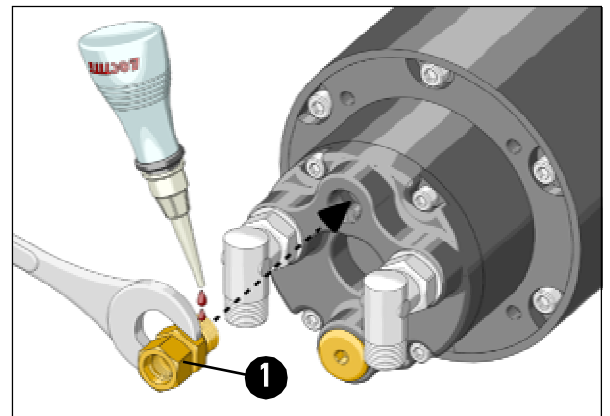

- 3 Connecter les tuyaux comme indiqué dans la figure selon les instructions des manuels relatifs.

POSTE DE GOUVERNEMENT PRIMAIRE

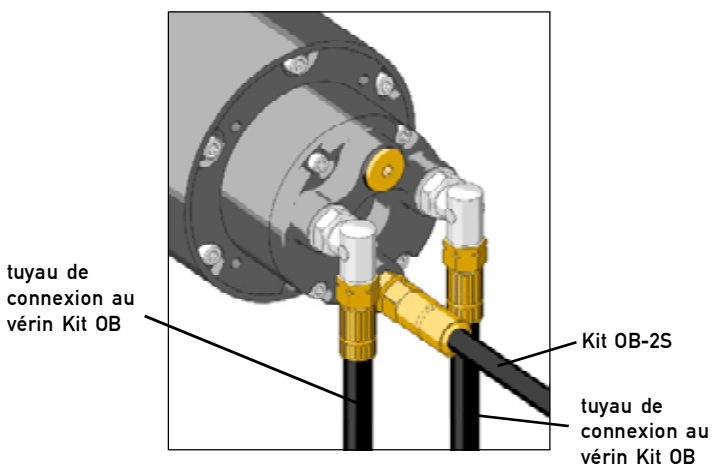

POSTE DE GOUVERNEMENT SUPPLEMENTAIRE

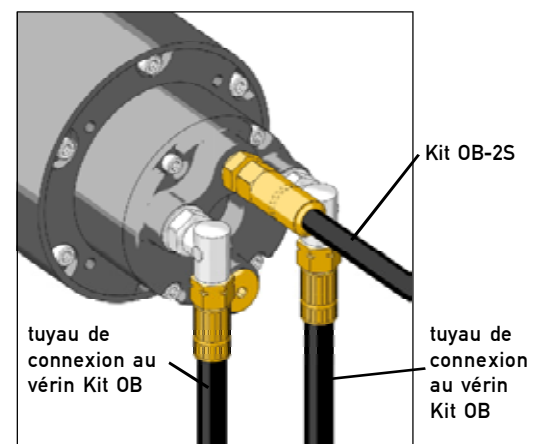

⚠ AVERTISSEMENT

Assembler les tuyaux loin de sources de chaleur et de substances chimiques. Protéger les tuyaux qu'il faut faire passer à travers des cloisons à l'aide de connecteurs de cloison adéquats. Les courbes doivent être parfaitement lisses; tout tuyau plié ou toute bosselure empêcheraient le libre passage de l'huile hydraulique.

⚠ AVERTISSEMENT

Maintenir propre. S'assurer qu'il n'y ait pas de poussière et de saleté dans les lieux de travail. Les bouchons de protection des trous filetés ne doivent être enlevés qu'avant de connecter les raccords et les tuyaux. S'assurer que les tuyaux soient propres et sans bavures. En cas d'emploi de tuyaux de cuivre ou d'acier, le nettoyage est obligatoire. L'emploi de tuyaux différents du Kit OB est sous le couvert de l'installateur.

⚠ AVERTISSEMENT

À la fin de l'installation vérifier que les tuyaux n'interfèrent pas avec le moteur et avec des parties fixes ou mobiles du bateau ou du système de gouvernement lui-même.

⚠ AVERTISSEMENT

Le rayon minimum de courbure des tuyaux est de 250 mm. Toute courbure excessive du tuyau pourrait en causer une rupture interne en compromettant le bon fonctionnement du système. Dans ce cas il faut remplacer le tuyau endommagé.

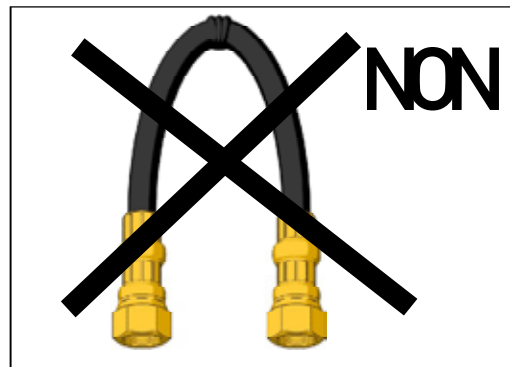
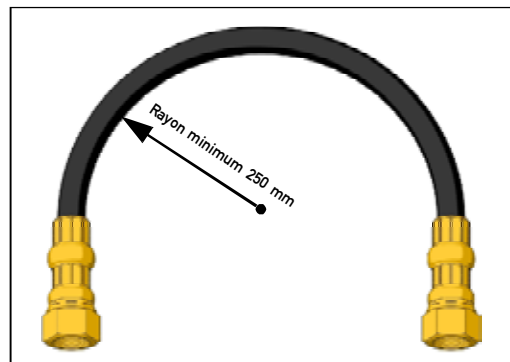

3.10.2 Choix des tuyaux rigides pour le modèles UP39-I R et UP45-I R



| MATERIEL TUYAU EN ACIER | SPECIFICATIONS | STRUCTURE | CONDITIONS | TOLERANCE DIAM. EXT./EPAISSEUR PAROI | SURFACE |
|-----------------------------|--------------------|----------------------------|----------------------|--------------------------------------|---|
| St. 37.4 (=St 35.4, 1.0255) | DIN 2391/ DIN 1630 | Etiré à froid sans soudure | NBK, DIN 2391-2 | DIN 2391-1-C | Phosphatée, lubrifiée ou en A3C (galvanisée et chromée jaune) |
| E 235 (= 1.0308) | EN 10305-4 | | +N (=recuit normal) | EN 10305-4 | |
| R37 | ISO 3304 | | NBK (=recuit normal) | ISO 3304 | |
| St 52.4 (= 1.0580) | DIN 2391 | | NBK, DIN 2391-2 | DIN 2391-1 | |
| E355 (= 1.0580) | EN 10305-4 | | +N (=recuit normal) | EN 10305-4 | |
| R50 | ISO 3304 | | NBK (=recuit normal) | ISO 3304 | |

| MATERIEL TUYAU ACIER INOXYDABLE | SPECIFICATIONS | STRUCTURE | CONDITIONS | TOLERANCE DIAM. EXT./EPAISSEUR PAROI | SURFACE |
|---------------------------------|--------------------------|----------------------------|--|---------------------------------------|---------|
| 1.4571 (= TP 316 Ti) | DIN 2391 | Etiré à froid sans soudure | Recuit complètement DIN 17458 | DIN 2391-1 | Lisse |
| 1.4541 (= TP 321) | | | | | |
| 1.4404 (= TP 316L) | EN ISO 1127 ou Astm A269 | | Recuit complètement | D4/T3 (EN ISO 1127) | |
| 1.4301 (= TP 304) | | | | | |
| 1.4401 (= TP 316) | EN ISO 1127 | Tuyau à souder | DIN 17457-K2 pour diam. Ext. 6-12 mm, soudé étiré à froid (CDW) avec une surface extérieure polie pour diam. Ext. 14-42 mm | Lisse, avec soudure presque invisible | |
| 1.4301 (= TP 304) | | | | | |
| 1.4541 (= TP 321) | | | | | |

| MATERIEL TUYAU EN CUIVRE | SPECIFICATIONS | STRUCTURE | CONDITIONS | TOLERANCE DIAM. EXT./EPAISSEUR PAROI | SURFACE |
|--------------------------|----------------|--------------------|------------|--------------------------------------|---------------------|
| R 290 | EN 1057 | Tuyau sans soudure | EN 1057 | EN 1057 | Propre, poli, lisse |



NOTE

Ce tableau est indiqué dans un but seulement illustratif.

ULTRAFLEX n'est pas responsable sur le choix du tuyau qui doit être effectué par l'installateur selon la pression d'emploi.

⚠ AVERTISSEMENT

La soupape de protection de surpressions des pompes UP Séries **ULTRAFLEX** protège le système contre les pressions supérieures à 70 bar (1000 PSI) environ.

Les références normatives sont mises à jour à la date de publication de ce document. L'installateur doit vérifier la présence des mis à jour éventuels.

3.10.3 Connexion des tuyaux au système modèles UP39-I R et UP45-I R



- 1 Connecter les tuyaux rigides (diamètre extérieur 12mm) de connexion entre la pompe et le vérin.
- 2 En cas d'installation d'un ou de plusieurs postes de gouvernement supplémentaires (sauf les pompes série "NV") il faut utiliser le kit OB 120 U-2S selon les instructions adéquates.

Positionner les raccords droits (1) sur les pompes pour le tuyau de 12mm comme indiqué dans la figure. Appliquer un produit scellant type Loctite 542 ou Loctite 545 sur le filet des raccords. Emboîter et visser manuellement les raccords coniques (1) jusqu'à les insérer complètement; ensuite les serrer à l'aide d'une clé hexagonale de 7/16" avec un couple de serrage de 17,6 Nm (156 lb ft).

⚠ AVERTISSEMENT

Ne pas utiliser de téflon ou n'importe quel autre type de ruban adhésif. Faire très attention au positionnement de la colle pour sceller qui bloquerait le système en le rendant inutilisable si elle était insérée dans le système.

POSTE DE GOUVERNEMENT PRIMAIRE

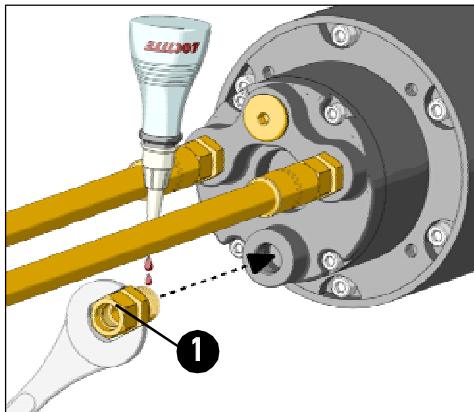

POSTE DE GOUVERNEMENT SUPPLEMENTAIRE

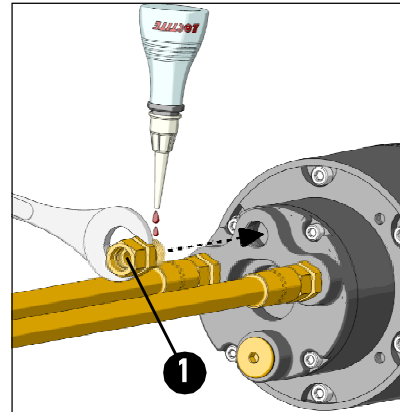

- 3 Connecter les tuyaux comme indiqué dans la figure et serrer avec un couple adéquat selon les spécifications du constructeur du tuyau.

POSTE DE GOUVERNEMENT PRIMAIRE

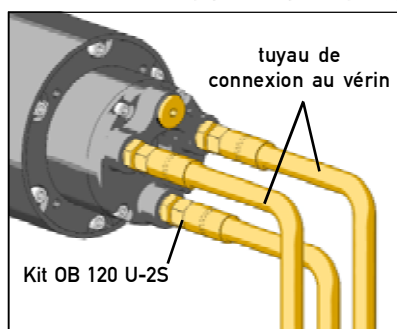

POSTE DE GOUVERNEMENT SUPPLEMENTAIRE

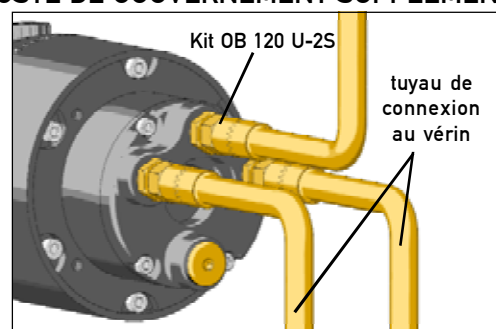

NOTE

Le Kit OB 120 U-2S est fourni séparément pour les applications avec poste double et il inclut tous les raccords nécessaires pour le tuyau en cuivre de 12mm. Ce dernier doit être acheté séparément.

⚠ DANGER

Les raccords assemblés sur la pompe NE sont PAS orientables. Leur dévissage éventuel ne provoque pas la rupture consécutive en rendant la pompe inutilisable.

NOTE

L'assemblage du tuyau rigide (coupe, courbure et passage cloison) devra être effectué par du personnel spécialisé en suivant les indications du constructeur. En cas de tuyaux en cuivre ou en acier le fluxage est obligatoire.

3.1 Remplissage et purge



Après la première installation et après toute opération d'entretien il faut remplir le système avec de l'huile hydraulique. Cette opération permet d'éliminer complètement l'air du système et en assure le bon fonctionnement. Le système hydraulique doit être rempli depuis le point le plus haut du système lui-même, c'est-à-dire du poste de gouvernement supérieur.

⚠ ATTENTION

Pour éviter la formation de bulles d'air dans l'huile, il faut remplir lentement le réservoir.

⚠ AVERTISSEMENT

Les opérations de remplissage et de purge doivent être effectuées au moins par deux opérateurs.

NOTE

Les opérations de remplissage et de purge peuvent être facilitées à l'aide de l'équipement de purge automatique BUBBLE BLUSTER® (fourni séparément).

⚠ DANGER

Utiliser de l'huile **ULTRAFLEX** ou des huiles compatibles.

L'huile hydraulique OL150 est spécifiquement formulée pour **ULTRAFLEX** afin de maintenir le plus longtemps possible pendant le temps le haut niveau de qualité et de performance des produits **ULTRAFLEX**. Sa formule particulière "Sans Zinc" favorise la protection contre l'oxydation marine. Le mélange particulier des composants antiusures et stabilisants, dont OL150 est composé, permettent d'obtenir un résultat optimal en termes de durée du produit et de constance de performance dans les différentes conditions environnementales. L'huile hydraulique **ULTRAFLEX** est conforme à la norme ISO 10592 relative aux systèmes de gouvernement hydrauliques. **ULTRAFLEX** n'est pas responsable de tout dommage ou de toute diminution des performances à cause de l'emploi des huiles hydrauliques différentes de OL150.

⚠ DANGER

N'utiliser dans aucun cas d'huiles de transmission type ATF Dexron II ou d'huiles pour les freins qui peuvent provoquer le blocage du système de gouvernement.

Huiles compatibles avec OL150 **ULTRAFLEX** sont:

- Shell Tellus T15 et Shell Tellus T22
- Mobil DTE 11M

NOTE

ULTRAFLEX ne peut pas assurer la compatibilité des huiles indiquées avec OL150 en cas de variation aux formulations par les producteurs des huiles, en particulier la société ne peut pas assurer la correspondance à la norme ISO 10592 relative aux systèmes de gouvernement hydrauliques. **ULTRAFLEX** n'est pas responsable de toute diminution des performances et/ou de la durée.

Les jours après le remplissage il faut contrôler le niveau de l'huile; si nécessaire, en ajouter.

Au début le niveau de l'huile peut descendre, car des quantités petites d'air peuvent se libérer de façon homogène. Selon les différents types d'installation, il faut donc effectuer les différentes procédures de purge, comme indiqué à la page suivante.



3.11.1 Positionnement de la bouteille de l'huile

Pour effectuer cette opération il faut avoir le kit de remplissage huile (1 pointeau, 1 tuyau transparent, 1 raccord porte tuyau et 1 bec pour la bouteille huile) NON fourni.

- Enlever le bouchon provisoire de la pompe et insérer le raccord de remplissage.
- Fixer un bec à une bouteille nouvelle d'huile hydraulique, en connectant le tuyau flexible du raccord de remplissage au bec de la bouteille.
- Renverser la bouteille et la percer à l'aide de l'aiguille, comme indiqué dans la figure, de sorte à faciliter le passage de l'huile vers la pompe. Remplir la pompe jusqu'à faire disparaître les bulles d'air dans le tuyau flexible.

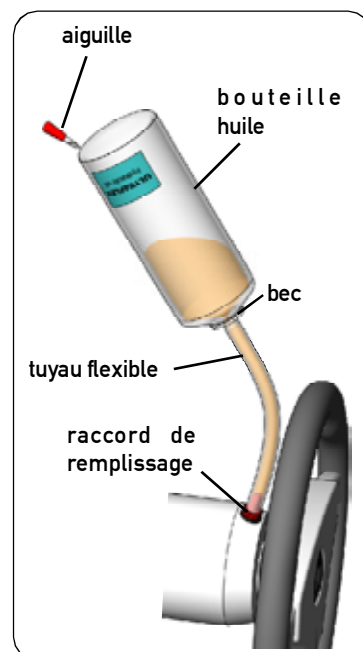

⚠ AVERTISSEMENT

Lors du remplacement des bouteilles d'huile pendant la procédure de remplissage, fermer toutes les soupapes de purge du vérin/des vérins. Pour vidanger le système, vérifier que l'huile soit toujours présente dans le tuyau flexible. Si pendant la procédure de purge de l'air entrerait dans le système, toute la procédure devra être répétée.

⚠ ATTENTION

Remplacer la bouteille avant sa vidange et ne réemployer l'huile sortie du système qu'après au moins 24 heures.

3.11.2 Procédure de purge

NOTE

Effectuer la procédure de purge comme décrit dans le manuel d'installation et d'entretien du vérin utilisé; ensuite obtenir le niveau d'huile désiré en tournant le volant d'un demi-tour et en faisant sortir l'huile de la soupape de purge. Fermer la soupape et contrôler le système.

3.12 Recommandation générale

⚠ AVERTISSEMENT

Il est très important de vérifier que l'air sorte complètement du système avant d'utiliser le bateau! On conseille d'essayer de déplacer manuellement le / les moteur/s ou le / les gouvernail/s vers bâbord et tribord, en faisant attention à tous les mouvements du corps du vérin sur sa tige.

Tout mouvement excessif entre le corps et la tige du vérin indique qu'il y a encore de l'air à purger dans le système. La présence d'air dans le système peut causer des réponses incorrectes aux commandes, avec risque d'endommagement, de lésion ou de mort.

⚠ AVERTISSEMENT

S'assurer que le système réponde immédiatement en déplaçant la pompe.

⚠ DANGER

Après 24 heures répéter la procédure de purge et vérifier l'absence de pertes.



4 AVERTISSEMENTS DE SECURITE

Cette section décrit les normes de sécurité à suivre pour utiliser correctement l'appareillage. On recommande de lire cette section avec beaucoup d'attention. On recommande aussi de lire les manuels fournis avec les autres composants du système de gouvernement.

4.1 Normes de sécurité pendant l'installation et l'emploi

RESPECTER RIGOREUSEMENT les précautions et les critères de sécurité indiqués ci-dessous. La Société **ULTRAFLEX** décline toute responsabilité au cas où l'utilisateur ne les respecterait pas; elle n'est pas non plus responsable pour tout type de négligence commise pendant l'emploi du système.

DANGER

- **NE PAS INSERER LES MAINS ENTRE LES ORGANES EN MOUVEMENT.**
- Ne pas désactiver ou déconnecter les dispositifs de sécurité.
- Ne pas modifier ou ajouter n'importe quel dispositif au système, sans autorisation écrite ou intervention technique de la Société **ULTRAFLEX** qui atteste dans la description de l'intervention la modification effectuée.
- Ne pas utiliser l'appareillage pour un but différent de celui auquel il a été destiné et qui est spécifié dans le manuel d'installation et d'entretien.
- Ne pas faire exécuter l'installation par du personnel pas spécialisé.
- Ne pas désassembler les connexions hydrauliques sans avoir déchargé complètement l'huile du système. Les tuyaux peuvent contenir de l'huile à pression.
- En cas d'installation avec poste double, ne **JAMAIS** agir simultanément sur les deux postes. En effet, les deux postes sont toujours actifs sur le système de gouvernement. L'effet de la rotation du volant sur les deux postes doublera en causant une manoeuvre indésirable.

AVERTISSEMENT

- Ne pas monter sur le vérin.
- Après avoir installé et purgé le système, effectuer un contrôle avant de commencer la navigation. Tourner le volant jusqu'au point de fin de course du/des vérin/vérins installé/installés. Répéter la manoeuvre en tournant le volant dans la direction opposée. Répéter l'opération avec tous les gouvernails installés afin d'assurer qu'ils soient installés correctement et que le système fonctionne bien.
- Faire très attention pendant l'application du produit bloquant (type Loctite). S'il atteint le système hydraulique, il cause des dommages et des ruptures.
- Pour sceller les raccords, ne jamais utiliser du ruban en téflon ou n'importe quel type de ruban adhésif qui pourrait être aspiré par le système et l'endommager irréparablement.
- Pendant l'installation du système, faire très attention à nettoyer soigneusement, pour éviter la pénétration de n'importe quel corps étranger dans le système lui-même. Même un objet très petit pourrait causer des dommages permanents qui ne sont pas détectés immédiatement.
- Eviter tout rayon de courbure trop étroit des tuyaux.
- Eviter le contact des tuyaux avec des bords ou des arêtes de coupe.
- Eviter le contact des tuyaux avec des sources de chaleur.

4.2 Habillement

AVERTISSEMENT

Pendant les phases d'installation, inspection ou entretien, IL EST RIGOREUSEMENT INTERDIT de porter de colliers, de bracelets ou de vêtements qui pourraient s'engager dans les parties en mouvement.

5 ENTRETIEN

5.1 Entretien ordinaire

⚠ ATTENTION

La non-observation des contrôles d'entretien peut causer la perte de guidage avec des dommages matériels et/ou des lésions personnelles. Les conditions requises pour l'entretien varient selon le climat, la fréquence et le mode d'emploi. Des inspections au moins annuelles sont nécessaires; elles doivent être effectuées par un mécanicien nautique spécialisé. Il faut contrôler les raccords et l'état des joints du vérin et de la direction, afin de prévenir toute sorte de fuite; les remplacer si nécessaire. Pour maintenir un niveau adéquat d'huile dans le réservoir remplir et purger le système comme indiqué dans le manuel au paragraphe 3.11 et dans les procédures de purge des vérins **ULTRAFLEX**. Tous les six mois contrôler l'usure des tuyaux et de tout le système, la fixation des écrous et des boulons et s'assurer qu'ils soient parfaitement intacts. Nettoyer le système avec de l'eau et du savon pas abrasif.

⚠ DANGER

Utiliser exclusivement des huiles hydrauliques compatibles, indiquées au paragraphe "caractéristiques techniques" et "remplissage et purge". Ne jamais utiliser d'huiles pour freins ou de fluides pour transmissions automatiques (ATF).

⚠ ATTENTION

En cas de désassemblage des écrous autofreinés, ces derniers devront être remplacés. (Contacter notre service d'assistance, voir page 74).

5.2 Désassemblage volant

Pour extraire le volant de l'arbre de la pompe, utiliser un extracteur adéquat.

⚠ AVERTISSEMENT

Ne pas utiliser le marteau ou d'autres outils qui pourraient endommager irréparablement la pompe.

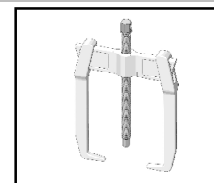

5.3 Recherche des pannes

⚠ AVERTISSEMENT

Toutes les fois que les contrôles suivants nécessitent du désassemblage des composants du système de gouvernement, il faut demander l'intervention du personnel qualifié. La Société **ULTRAFLEX** offre des indications générales et décline donc toute responsabilité pour les informations et les conséquences dérivant d'un désassemblage incorrect.

| PROBLEME | CAUSE POSSIBLE | INTERVENTION |
|--|--|--|
| La direction est bloquée pendant la phase de remplissage. | <ul style="list-style-type: none"> Blocage dans les tuyaux entre la pompe et le vérin. | <ul style="list-style-type: none"> Remplacer les tuyaux. <p>⚠ DANGER Le tuyau endommagé doit être remplacé. S'il n'est pas remplacé, cela peut causer la perte de contrôle et provoquer des lésions personnelles graves ou des dommages aux biens.</p> |
| Il est difficile de remplir le système. L'air gargouille dans la partie supérieure du réservoir de la pompe même après avoir rempli totalement le système. | <ul style="list-style-type: none"> Air dans le système. | <ul style="list-style-type: none"> Répéter la procédure de remplissage et de purge du système. Installer les tuyaux horizontalement et en tout cas avec une inclinaison maximum d'environ 3cm par mètre. |
| | <ul style="list-style-type: none"> Pertes depuis un raccord de purge du vérin. | <ul style="list-style-type: none"> Fermer à fond le raccord de purge sur le vérin. |
| | <ul style="list-style-type: none"> Tuyau enroulé. | <ul style="list-style-type: none"> Dérrouler et redresser le tuyau. |
| | <ul style="list-style-type: none"> Pompe assemblée avec le trou de remplissage en position basse. | <ul style="list-style-type: none"> Assembler la pompe avec le trou de remplissage en position haute. |



| | | |
|--|--|--|
| <p>La direction est rigide et difficile à manoeuvrer, même quando le bateau est à l'arrêt.</p> | <ul style="list-style-type: none"> • Rétrécissement dans les tuyaux ou dans les raccords. • Air dans l'huile. | <ul style="list-style-type: none"> • Chercher le rétrécissement et l'éliminer. • Répéter la procédure de remplissage et de purge du système. |
| <p>La direction est rigide et difficile à manoeuvrer, même quando le bateau est à l'arrêt.</p> | <ul style="list-style-type: none"> • Emploi incorrect de l'huile. | <ul style="list-style-type: none"> • Décharger immédiatement le système de remplissage et de purge. <p>⚠ AVERTISSEMENT La Société ULTRAFLEX décline toute responsabilité et la garantie est automatiquement annulée en cas de dommages causés par l'emploi de fluides différents de ceux qui sont recommandés dans ce manuel.</p> |
| <p>La direction est rigide et difficile à manoeuvrer, même quand le bateau est à l'arrêt, si l'on utilise des vérins non équilibrés.</p> | <ul style="list-style-type: none"> • Saleté ou copeaux dans la soupape. | <p>⚠ AVERTISSEMENT Ne pas utiliser le bateau et demander l'intervention d'un technicien spécialisé pour le nettoyage de la soupape.</p> |
| <p>La direction se manoeuvre facilement dans le quai, mais elle est rigide quand le bateau est en mouvement.</p> | <ul style="list-style-type: none"> • Le volant est trop petit. | <ul style="list-style-type: none"> • Remplacer le volant avec un volant plus grand. <p>⚠ AVERTISSEMENT</p> <ul style="list-style-type: none"> • Seulement dans les dimensions maximum admises par la direction. |
| | <ul style="list-style-type: none"> • Le réglage du correcteur de stabilité est incorrect. | <ul style="list-style-type: none"> • Régler le correcteur de stabilité. |
| | <ul style="list-style-type: none"> • Air dans l'huile. | <ul style="list-style-type: none"> • Contrôler le niveau de l'huile et répéter la procédure de purge comme indiqué dans le manuel. |
| <p>Lorsqu'on tourne le volant, la tige (vérins à tige mobile) ou le corps (vérins à tige fixe) du vérin ne se déplacent pas.</p> | <ul style="list-style-type: none"> • Air dans le système. | <ul style="list-style-type: none"> • Répéter la procédure de remplissage et de purge du système. |
| | <ul style="list-style-type: none"> • Perte d'huile. | <ul style="list-style-type: none"> • Chercher la perte et s'adresser à du personnel qualifié. |
| | <ul style="list-style-type: none"> • Pompe assemblée avec le trou de remplissage en position basse. | <ul style="list-style-type: none"> • Assembler la pompe avec le trou de remplissage en position haute. |
| <p>Pertes d'huile des raccords de la direction.</p> | <ul style="list-style-type: none"> • Raccords mal vissés ou avec couple de serrage insuffisant. | <ul style="list-style-type: none"> • Serrer les raccords. Appliquer un couple maximum de 20Nm (15 in.lbs). |
| | <ul style="list-style-type: none"> • Manque de produit scellant pour les raccords. <p>⚠ AVERTISSEMENT Pour sceller les raccords ne jamais utiliser du ruban en téflon ou du ruban adhésif.</p> | <ul style="list-style-type: none"> • Vider le système et le désassembler. Enlever les raccords et nettoyer les filetages de l'huile. Positionner le produit scellant, visser les raccords, installer la pompe. <p>⚠ AVERTISSEMENT Cette opération terminée, il faut effectuer la purge à nouveau.</p> |
| <p>Pertes d'huile du bouchon du réservoir.</p> | <ul style="list-style-type: none"> • Bouchon mal vissé. | <ul style="list-style-type: none"> • Visser le bouchon. |
| | <ul style="list-style-type: none"> • Bouchon avec évent placé sur la pompe supplémentaire positionnée en bas. | <ul style="list-style-type: none"> • Remplacer le bouchon avec évent avec le bouchon pour kit boîte de direction supplémentaire. |
| | <ul style="list-style-type: none"> • Joint usé ou endommagé. | <ul style="list-style-type: none"> • Remplacer le bouchon. |
| | <ul style="list-style-type: none"> • Niveau de l'huile trop haut. | <ul style="list-style-type: none"> • Suivre la procédure de maintien niveau huile décrite dans le manuel de la pompe. |



6 DEMOLITION

6.1 Démolition

Si le système de gouvernement doit être mis hors service pour quelques raisons que ce soit, les règles fondamentales suivantes doivent être observées pour la protection de l'environnement.

Gaines, conduits flexibles, composants de matériel plastique ou non métalliques, devront être désassemblés et éliminés séparément.

Le système de gouvernement CONTIENT DES HUILES POLLUANTES qui devront être éliminées selon les normes en vigueur.

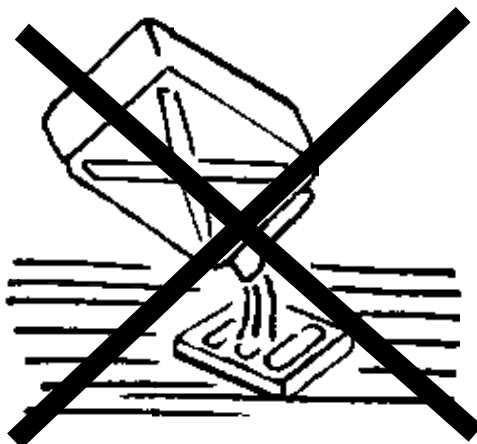

ULTRAFLEX S.p.A.

16015 Casella (Genova) Italia - Via Crose, 2